

SOFT

ZP7212.195E

Single lever basin mixer.



Single lever basin mixer with aerator, pop-up waste, flexible hoses.
Spout projection 5 1/16".
Water flow restricted to 1,2 GPM.

Finiture / Finishes



Chrome



Brushed Nickel

C3



Polished Nickel

C8

SOFT

ZP7212.195E Disegno Complessivo / Overall Drawing

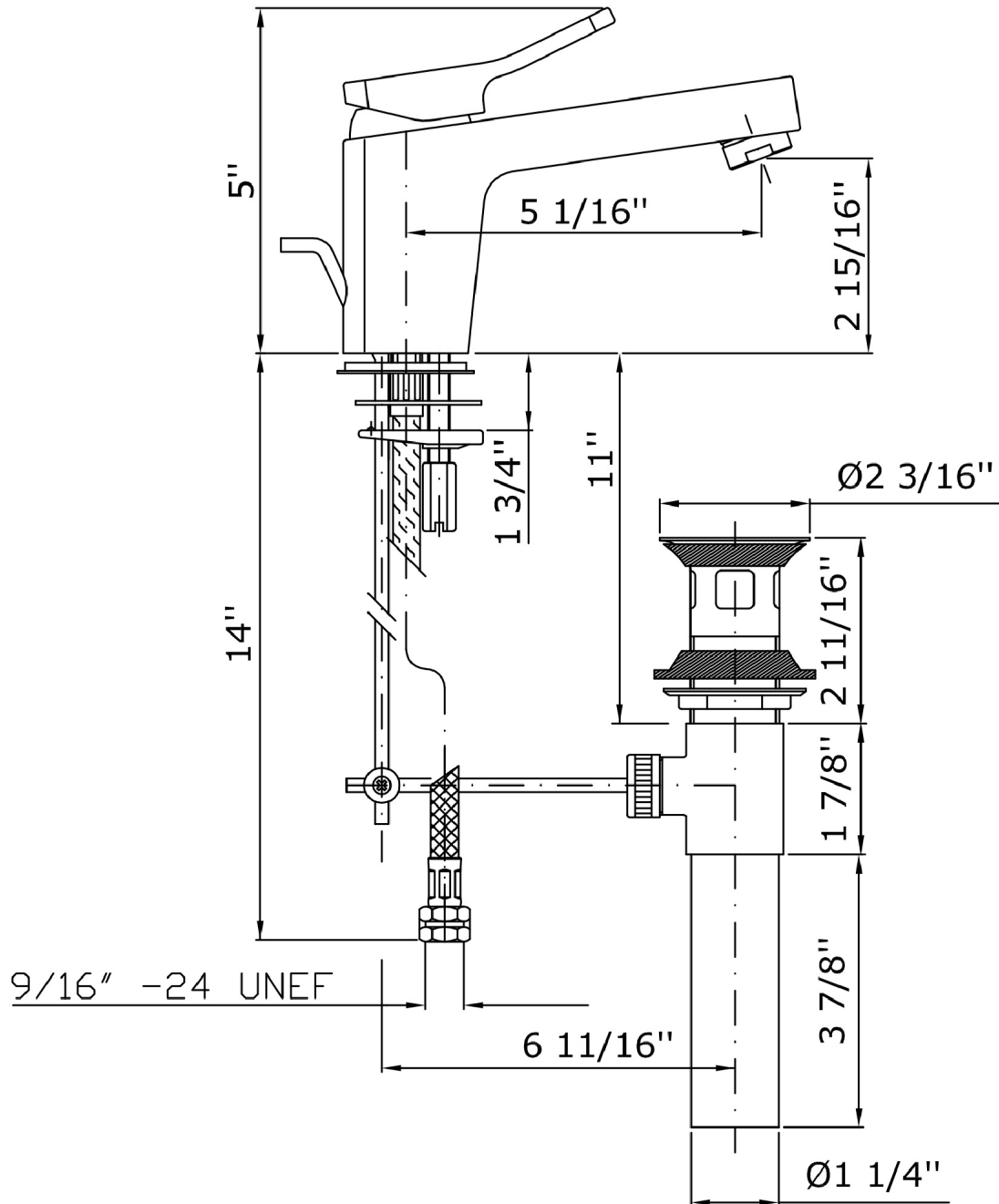

SOFT

ZP7212.195E Esplosi / Exploded

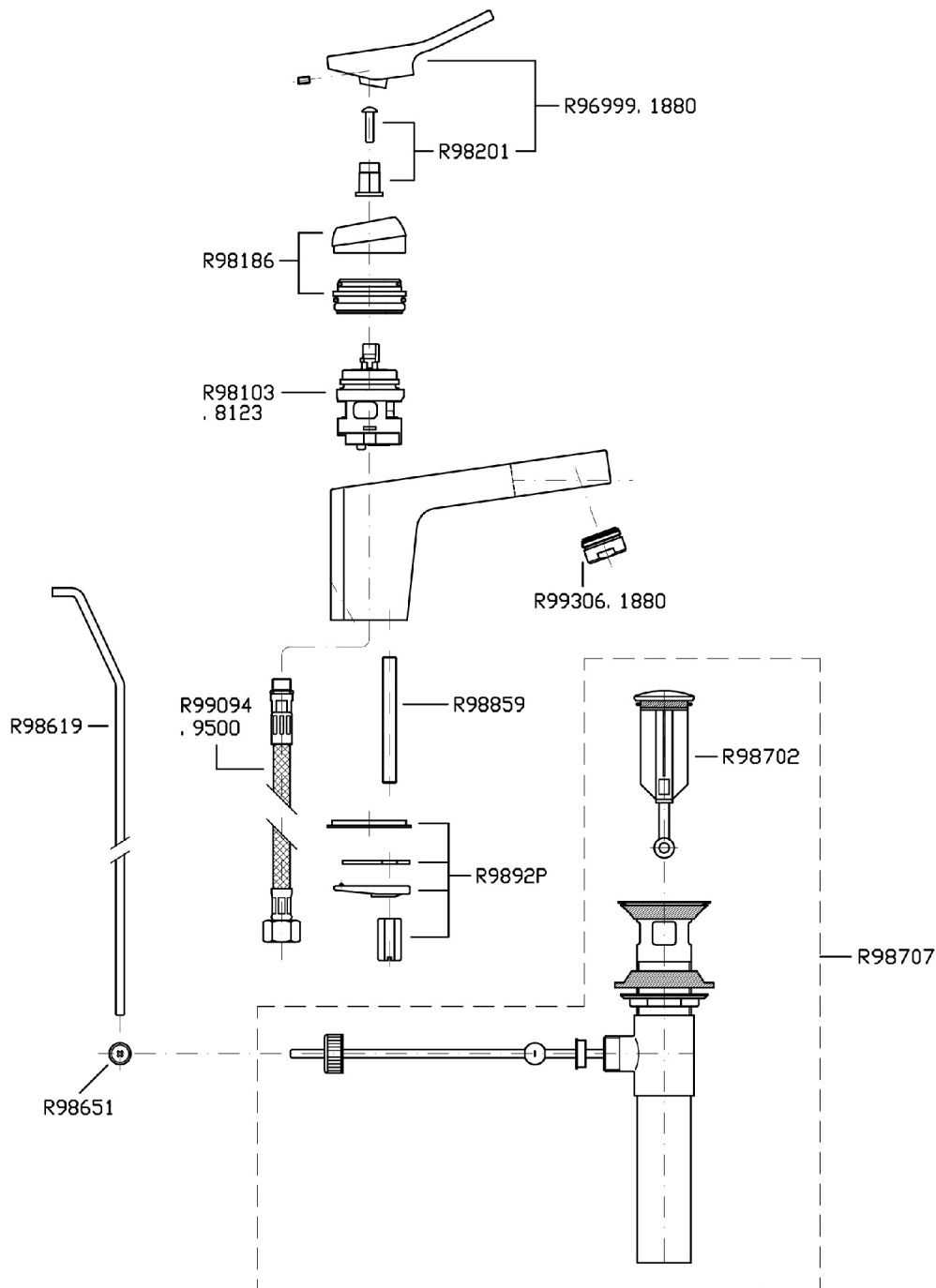

Marchio / Brand ZUCCHETTI

Classe / Class

SOFT

SOFT

ZP7212.195E Certificazioni / Certifications

USA

IAPMO

SOFT

ZP7212.195E Pesì e Misure / Weights and Sizes

Peso (Kg) Weight (lb)	2,7 (Kg)	5,95242 (lb)
Volume (dc3) - (in3)	7,43 (dc3)	0,000453 (in3)
h (mm) - (in)	90 (mm)	3,543309 (in)
L1 (mm) - (in)	250 (mm)	9,842525 (in)
L2 (mm) - (in)	330 (mm)	12,992133 (in)

