

Brand ZUCCHETTI

Class

BELLAGIO

BELLAGIO

ZB1699.190E 3 hole built-in basin mixer.



3 hole built-in basin mixer, with aerator.
Spout projection 7 1/2".
Water flow restricted to 1.2 GPM.

R99500.190E

Assembled rough-in part, interaxe 8"



Finishes



Chrome



Brushed Nickel

C3



Polished Nickel

C8



Gold

C40



Brushed Gold

C41

Brand ZUCCHETTI

Class

BELLAGIO

BELLAGIO

ZB1699.190E Overall Drawing

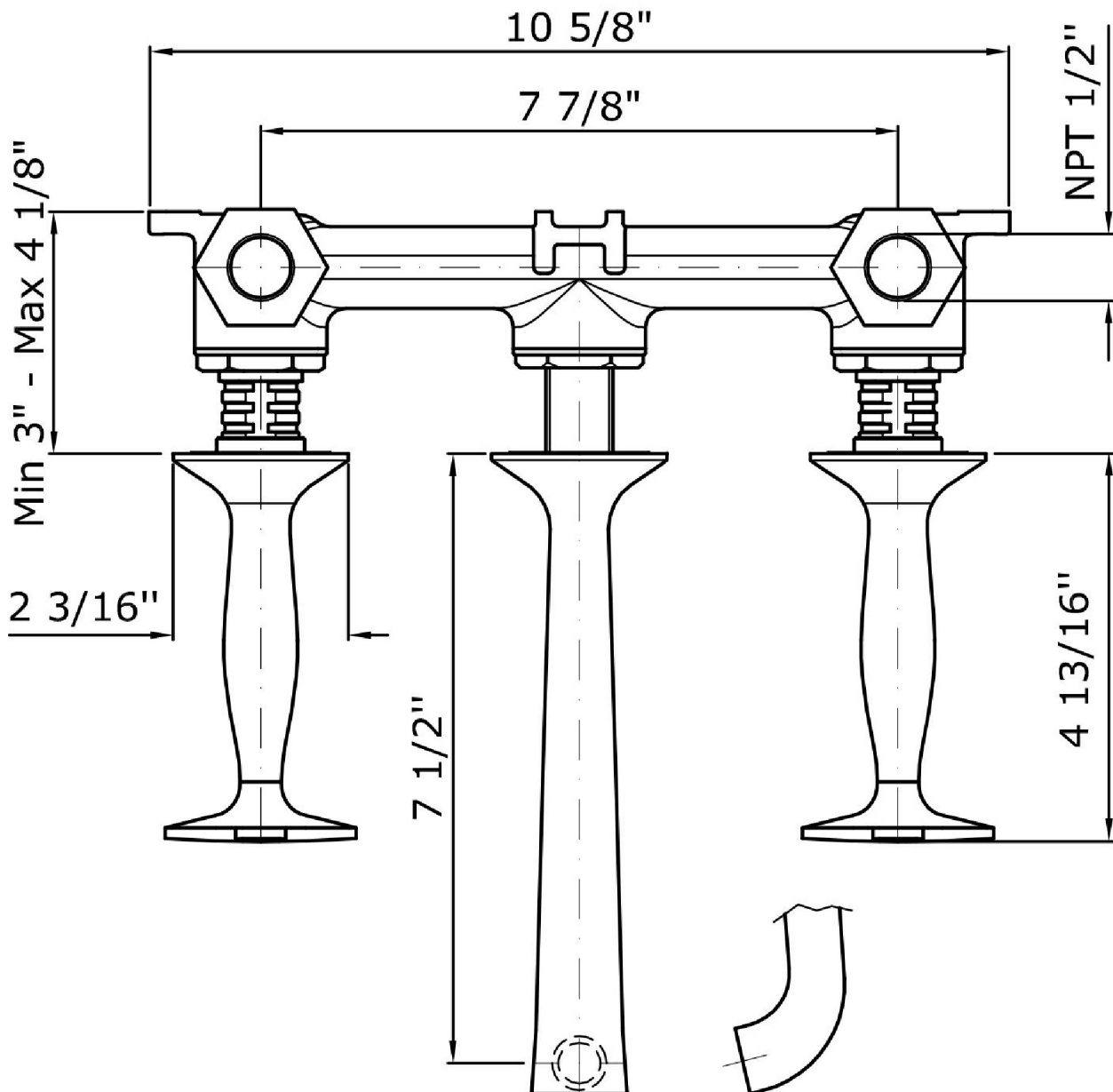

Brand ZUCCHETTI

Class

BELLAGIO

BELLAGIO

ZB1699.190E Exploded

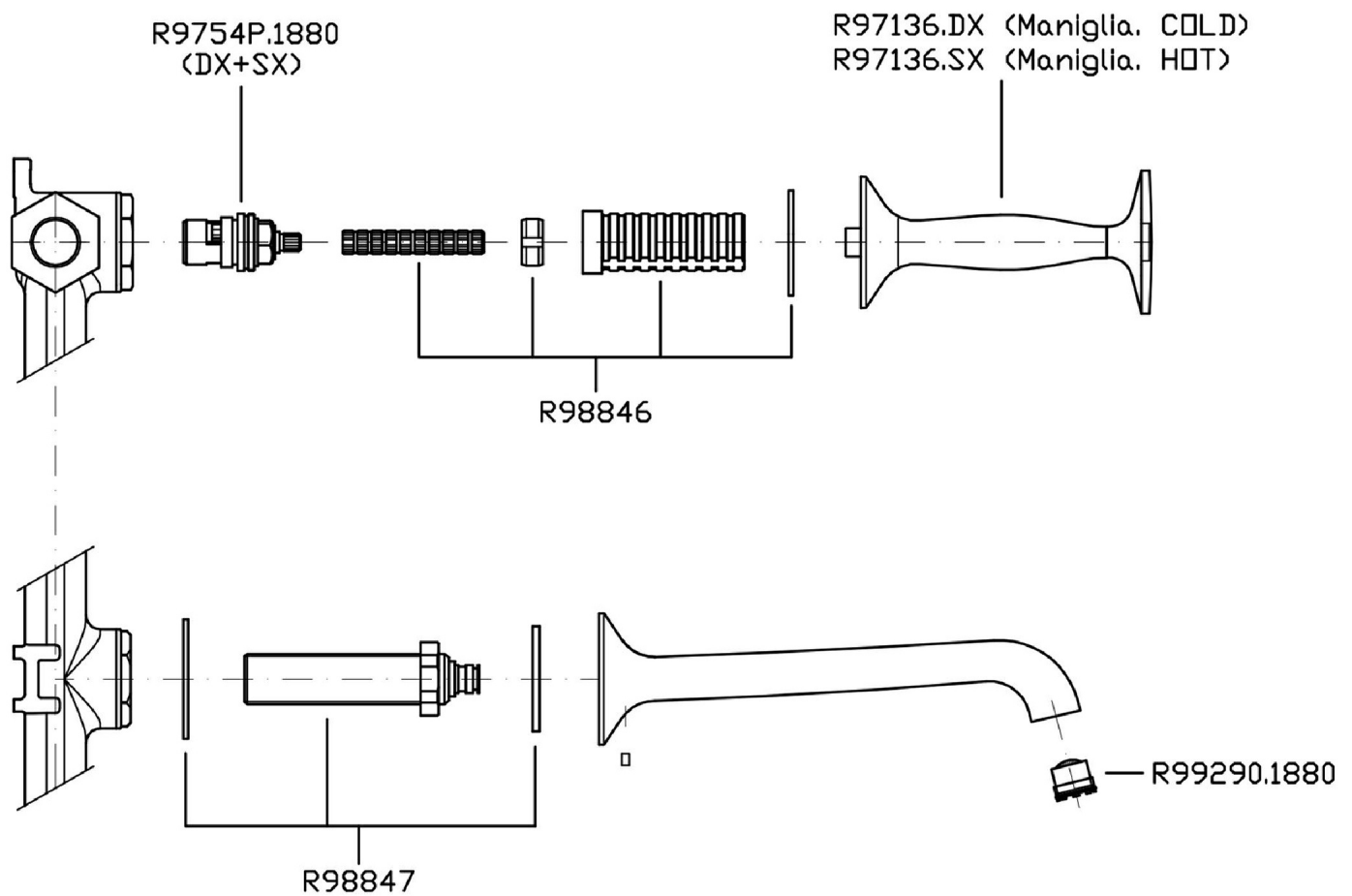

Brand ZUCCHETTI

Class

BELLAGIO

BELLAGIO

ZB1699.190E Certifications

USA

IAPMO

BELLAGIO

ZB1699.190E Weights and Sizes

Weight (lb)	2,31 (Kg)	5,092626 (lb)
Volume (dc3) - (in3)	7,43 (dc3)	0,000453 (in3)
h (mm) - (in)	90 (mm)	3,543309 (in)
L1 (mm) - (in)	250 (mm)	9,842525 (in)
L2 (mm) - (in)	330 (mm)	12,992133 (in)

