

AGUABLU

ZA5413.195E Electronic basin mixer.



Electronic basin mixer.
Thermostatic valve suggested to regulate temperature.
Spout projection 6 7/8".
Water flow restricted to 1,2 GPM.

Finiture / Finishes



Chrome

AGUABLU

ZA5413.195E Disegno Complessivo / Overall Drawing

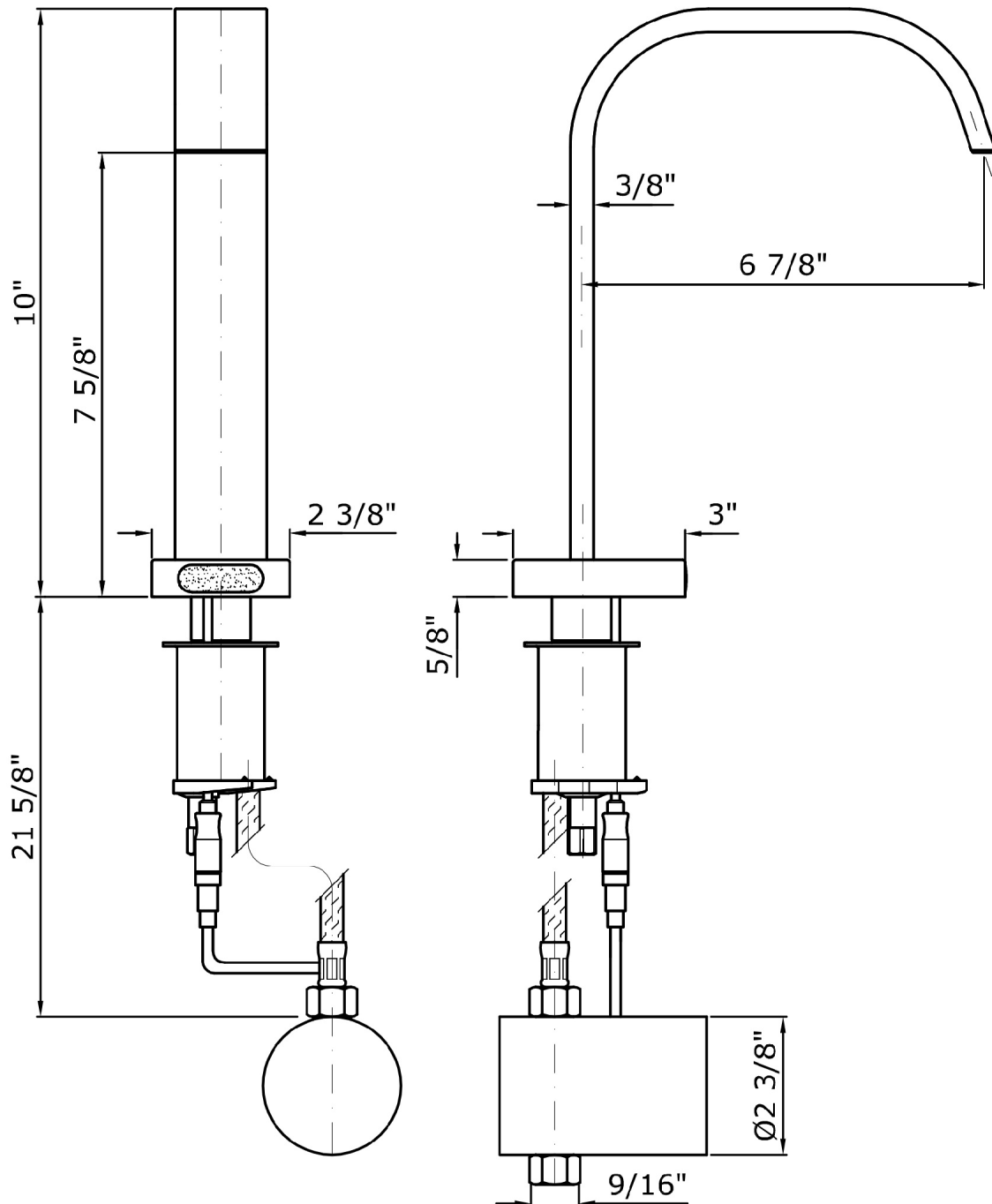

AGUABLU

ZA5413.195E Certificazioni / Certifications

USA

IAPMO

AGUABLU

ZA5413.195E Pesì e Misure / Weights and Sizes

Peso (Kg) Weight (lb)	2,76 (Kg)	6,084696 (lb)
Volume (dc3) - (in3)	11,01 (dc3)	0,000672 (in3)
h (mm) - (in)	90 (mm)	3,543309 (in)
L1 (mm) - (in)	335 (mm)	13,1889835 (in)
L2 (mm) - (in)	365 (mm)	14,3700865 (in)

