



Z415D

BODY ASSEMBLY W/ "TYPE D" STRAINER

SPECIFICATION SHEET

TAG _____

Dimensional Data (inches and [mm]) are Subject to Manufacturing Tolerances and Change Without Notice

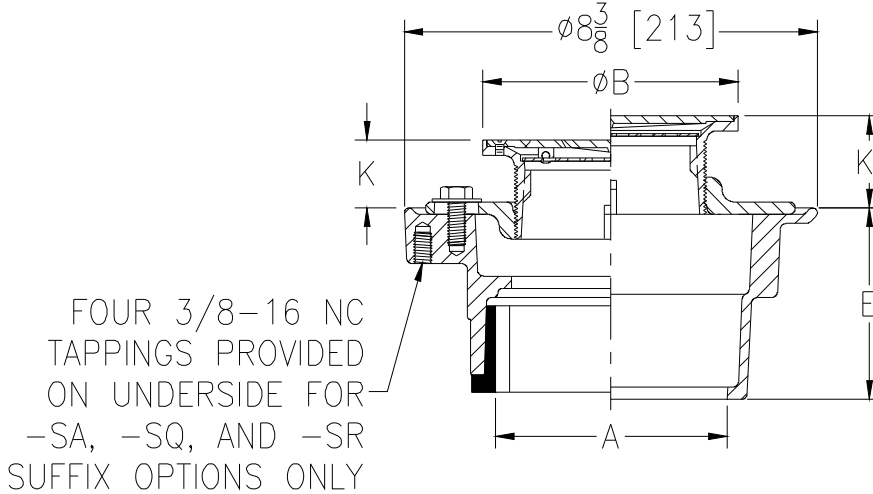

Dimensions in In [mm]						Approx. Wt. Lbs. [kg]
A - Pipe Size	B Strainer Dia.	K		K'		
		Min.	Max.	Min.	Max.	
2,3 [51,76]	5 [127]	1 [25]	1-1/2 [38]	1-3/32 [28]	2-1/4 [57]	12 [5]
2,3,4 [51,76,102]	6 [152]	1 [25]	1-25/32 [45]	1-13/32 [36]	2-17/32 [64]	14 [6]
2,3,4 [51,76,102]	7 [178]	1 [25]	2-1/8 [54]	1-23/32 [44]	2-7/8 [73]	15 [7]
3,4 [76,102]	8 [203]	1-5/32 [29]	2-1/8 [54]	1-3/4 [44]	2-7/8 [73]	17 [8]
6 [152]	8 [203]	1-5/32 [29]	2-1/8 [54]	1-3/4 [51]	2-7/8 [73]	19 [89]

ENGINEERING SPECIFICATION: ZURNZN415D

Floor and shower drain, Dura-Coated cast iron body with bottom outlet, combination invertible membrane clamp and adjustable collar with seepage slots and "TYPE D" polished, hinged solid, nickel bronze, light-duty strainer.

OPTIONS (Check/specify appropriate options)

PIPE SIZE	(Specify size/type) OUTLET	'E' BODY HT. DIM.
2,3,4 [51,76,102]	_____ IC Inside Caulk	4-3/16 [106]
2 [51]	_____ IP Threaded	2-7/16 [62]
3 [76]	_____ IP Threaded	2-3/4 [70]
4 [102]	_____ IP Threaded	2-13/16 [71]
6 [152]	_____ IP Threaded	2-7/8 [73]
2,3,4 [51,76,102]	_____ NH No-Hub	3-13/16 [97]
2,3,4 [51,76,102]	_____ NL Neo-Loc	3-7/8 [98]

PREFIXES

- _____ ZB D.C.C.I. Body Assembly w/ Polished Bronze Top
- _____ ZN D.C.C.I. Body Assembly w/ Polished Nickel Bronze Top*

SUFFIXES

- | | |
|---|---|
| _____ -AR Acid Resisting Epoxy Coated Cast Iron | _____ -U 1-3 [25-76] High Extension Adapter |
| _____ -G Galvanized Cast Iron | _____ -V Backwater Valve |
| _____ -P Trap Primer Connection (Specify 1/2 [13] or 3/4 [19]) | _____ -VP Vandal-Proof Secured Top |
| _____ -PC Protective Cover | _____ -Y Sediment Bucket |
| _____ -SA Stabilizer Assembly (See Z1035) | _____ -90 90° Threaded Side Outlet Body Assembly (2,3 [51,76] Only) |
| _____ -SQ Stabilizer Q-Deck (See Z1035-Q) | |
| _____ -SR Stabilizer Ring | |
| _____ -TC Neo-Loc Test Cap Gasket (2,3,4 [51,76,102] NL Bottom Outlet Only) | |

* Regularly furnished unless otherwise specified.