

Engineering Specifications: Zurn AquaSpec® Z841X1-AF

Polished chrome-plated pre-rinse faucet with quarter turn ceramic disc cartridges, 2-1/2" [64mm] long swivel inlets (with integral stops) providing adjustable centers from 4" [102mm] to 8-3/8" [213mm], check stops and 2-1/2" [64mm] vandal resistant color-coded metal lever handles. Unit is furnished with a 24" [610mm] riser with a 36" [914mm] stainless steel spring hose, a self-closing 1.6 GPM @ 60 psi (6.1 l/min. @ 400 kPa) pre-rinse hand held valve with an insulated 6" [152mm] handle, a stay open clip, a pipe support, hose hook and a single valve Adapta faucet with a 9-1/2" [241mm] tubular brass swing spout with a female single screen outlet.

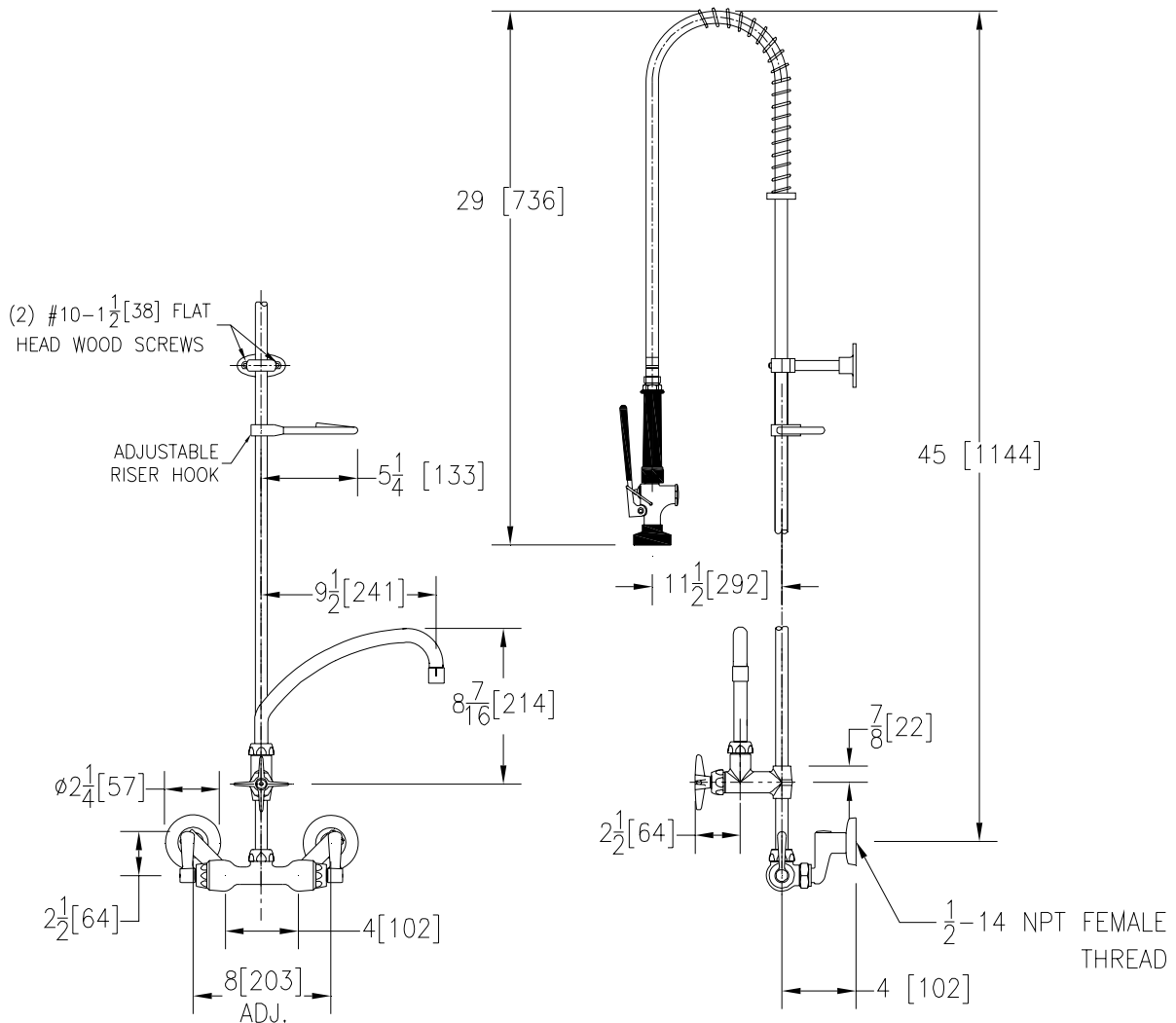

Note: All dimensions are for reference only. Do not use for pre-plumbing

OPTIONAL ACCESSORIES

Suffix	Description
___ -HCT	Hot/Cold Text Indexes
___ -PR2	Pre-rinse with Angle Spray Head, Rubber Bumper Spray Outlet and Self-closing Valve
___ -PR3	Pre-rinse with Angled Aerated Outlet and Self-closing Valve
___ -RC	Rough Chrome

ZURN INDUSTRIES, LLC ♦ COMMERCIAL BRASS OPERATION ♦ 2640 SOUTH WORK STREET ♦ FALCONER NY 14733

Phone: 1-800-997-3876 ♦ Fax: 1-919-775-3541 ♦ www.zurn.com

In Canada: ZURN INDUSTRIES LIMITED ♦ 3544 Nashua Drive ♦ Mississauga, Ontario L4V1L2 ♦ Phone: 905/405-8272 Fax: 905/405-1292