



# Model ZW209EX

## Pressure Reducing Valve

### Application

The Zurn Wilkins Model ZW209EX Pilot Operated Pressure Reducing Valve is designed for many applications where the reduction of high inlet pressures to safe and stable outlet pressure is required. The pilot assembly reacts to changes in downstream pressure allowing the main valve to modulate between the closed and open position ensuring a constant downstream set pressure. Once the downstream pressure reaches the pilot setting, the main valve will seal shut preventing damage downstream. Pressure regulation is not dependent upon flow rate, resulting in minimal pressure loss through the valve. In addition the Model ZW209EX comes standard with epoxy coating internally and externally for corrosion protection.

### Standards Compliance:

- ANSI/AWWA C530
  - Meets the requirements of NSF/ANSI 61\*
- \*\*(0.25% MAX. WEIGHTED AVERAGE LEAD CONTENT)

### Materials

Main Valve Body	Ductile Iron ASTM A536
Main Valve Bonnet	Ductile Iron ASTM A536
Disc Guide	Stainless Steel
Seat	Stainless Steel
Disc	Buna-N Rubber
Diaphragm	Nylon Reinforced Buna-N
Stem	Stainless Steel
Spring	Stainless Steel

\*The closing speed control (optional) on this valve should always be open at least three (3) turns off its seat.

### Standard Features

- Epoxy Coated, FDA Approved
- Pilot Assembly
- ANSI Class 150 Flanges
- Copper Tubing and Brass Fittings

### Schematic Diagram

Item	Description of Standard Features
1	Main Valve
2	SXL "Wye" Type Strainer
3	Restriction Fitting
4	NR3XL Pressure Reducing Control

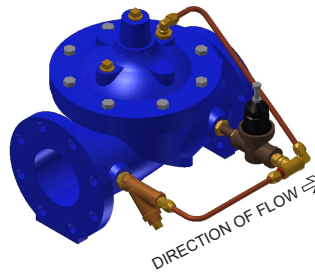
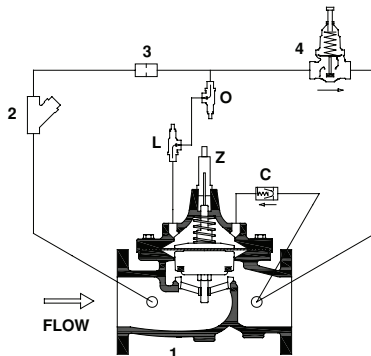

LEAD FREE



NSF/ANSI 61

### Sizes

GLOBE STYLE BODY SEE CONNECTIONS BELOW

### Options

(Add suffix letters to ZW209EX)

#### Function

- C - 40XL Hydraulic Check with Isolation Valve
- L - SC1 Closing Speed Control\*
- O - SC1 Opening Speed Control (Standard 1 1/4" - 4")

#### Body

- A - Angle Style Body 1-1/4"-10", DN32-DN250
- R - Reduced Port Body Flanged 3"- 10", DN80-DN250

#### Connections

Threaded ends 1 1/4" - 3", DN32-DN80: 400 psi, 2760 kpa, 27.6 bar max

- TH - NPT Threaded
- BS - Threaded British Pipe Parallel BSPP/G size ISO
- BT - Threaded British Pipe Parallel BSPT/Rc size ISO

Flanged 1 1/2" - 16", DN40-DN400: 250 psi, 1725 kpa 17.3 bar max (blank) ANSI Class 150

- BSD - BS10/AS2129 Table D Flanges
- BSE - BS10/AS2129 Table E Flanges
- PN6 - ISO Class PN6 Flanges
- PN10 - ISO Class PN10 Flanges
- PN16 - ISO Class PN16 Flanges

Flanged 1 1/2" - 16", DN40-DN400: 400 psi, 2760 kpa, 27.6 bar max

- BSF - BS10/AS2129 Table F Flanges
- BSH - BS10/AS2129 Table H Flanges
- PN25 - ISO Class PN25 Flanges
- Y - ANSI Class 300 Flanges

Grooved 1 1/2" - 10", DN40-DN250: 300 psi, 2070 kpa, 20.7 bar max

- G - (48.3, 60.3, 73.0, 88.9, 114.3, 168.3, 219.1, 373.0 mm pipe OD)
- BG - Grooved 2-1/2" or 6" (76.1, 165.1mm pipe OD)

#### Main Valve Options

- V - Viton Rubber Internals, rated 180°F (1-1/4"-6", only available with "LP" or "HP" Option)
- Z - ZPI Visual Position Indicator

#### Pilot System

- LP - 5-25 psi Low Pressure Range PV-PRD Pilot (replaces NR3XL)
- HP - 30-300 psi High Pressure Range PV-PRD Pilot (replaces NR3XL)
- RV - Pilot on Reverse Side

## Globe and Angle Main Valve Dimensions

DIM	FULL PORT	VALVE SIZE INCHES (mm)											
		1 1/4 (32)	1 1/2(38)	2 (50)	2 1/2 (65)	3 (80)	4 (100)	6 (150)	8 (200)	10 (250)	12 (300)	14 (350)	16 (400)
A	Threaded	7 1/4	7 1/4	9 7/16	11	12 1/2							
	Class 150 Flange		8 1/2	9 3/8	11	12	15	20	25 3/8	29 3/4	34	39	41 3/8
	Class 300 Flange		9	10	11 5/8	13 1/4	15 5/8	21	26 7/16	31 1/8	35 1/2	40 1/2	43 1/2
	Grooved		8 1/2	9	11	12 1/2	15	20	25 3/8	29 3/4			
B	Diameter	5 5/8	5 5/8	6 3/4	8	9 3/16	11 11/16	15 3/4	20 1/8	23 11/16	27 1/2	31 3/4	34 1/2
C	Max.	5 3/4	5 3/4	6 3/16	7 3/8	8	10 3/16	12 5/16	15 9/16	17 5/8	20 3/16	22 13/16	25 7/8
D	Threaded/Grooved	1 3/8	1 3/8	1 3/4	2 1/8	2 9/16	3 7/16	5	5	5 13/16	6 3/4	8 7/8	8 13/16
	Class 150 Flange		2 1/2	3	3 1/2	3 3/4	4 1/2	5 1/2	6 3/4	8	9 1/2	10 1/2	11 3/4
	Class 300 Flange		3	3 1/4	3 3/4	4 1/8	5	6 1/4	7 1/2	8 3/4	10 1/4	11 1/2	12 3/4
E	NPT Body Tap	3/8	3/8	3/8	1/2	1/2	3/4	3/4	1	1	1	1	1
F	NPT Cvr. Plug Tap	1/2	1/2	1/2	1/2	1/2	3/4	3/4	1	1	1	1	1
G	NPT Cover Tap	3/8	3/8	3/8	1/2	1/2	3/4	3/4	1	1	1	1	1
H	Threaded	3 1/4	3 1/4	4 3/4	5 1/2	6 1/4							
	Class 150 Flange		4	4 3/4	5 1/2	6	7 1/2	10	12 11/16	14 7/8			
	Class 300 Flange		4 1/4	5	6	6 7/16	8	10 1/2	13 1/4	15 9/16			
	Grooved		4 7/16	4 3/4	5 1/2	6	7 1/2	10	12 11/16	14 7/8			
J	Threaded	1 15/16	1 15/16	3 1/4	4	4 1/2							
	Class 150 Flange		4	3 1/4	4	4	5	6	8	8 5/8			
	Class 300 Flange		4 1/4	3 1/2	4 5/16	4 7/16	5 5/16	6 1/2	8 1/2	9 5/16			
	Grooved		3 3/16	3 1/4	4	4 1/4	5	6	8	8 5/8			
Valve Stem Internal Thread		10-32	10-32	10-32	10-32	1/4-20	1/4-20	1/4-20	3/8-16	3/8-16	3/8-16	3/8-16	3/8-16
Stem Travel (in)		7/16	7/16	3/4	7/8	1	1 3/16	1 3/4	2 3/8	2 13/16	3 7/16	3 13/16	4 5/16
Approx. Wt. (lbs)		22	26	36	55	70	130	240	440	720	820	1200	1550

## Reduced Port Main Valve Dimensions

DIM		VALVE SIZE INCHES (mm)				
		3" (80)	4" (100)	6" (150)	8" (200)	10" (250)
A	Class 150 Flange	10 1/4	14	17 3/4	21 7/16	26
	Class 300 Flange	11	14 1/2	18 11/16	22 7/16	27 7/16
B	Dia	6 3/4	9 3/16	11 11/16	15 3/4	20 1/8
C	Max	6 3/8	8 7/16	12 5/16	13 1/4	16 3/4
D	Class 150 Flange	3 3/4	4 1/2	5 1/2	6 3/4	8
	Class 300 Flange	4 1/8	5	6 1/4	7 1/2	8 3/4
E	NPT Body Tap	3/8	1/2	3/4	3/4	1
F	NPT Cvr. Plug Tap	3/8	1/2	3/4	3/4	1
G	NPT Cvr. Tap	3/8	1/2	3/4	3/4	1
Valve Stem Internal Thread		10-32	1/4-20	1/4-20	3/8-16	3/8-16
Stem Travel (in)		3/4	1	1 1/5	1 3/4	2 3/8
Approx. Wt. (Lbs)		35	80	140	275	480

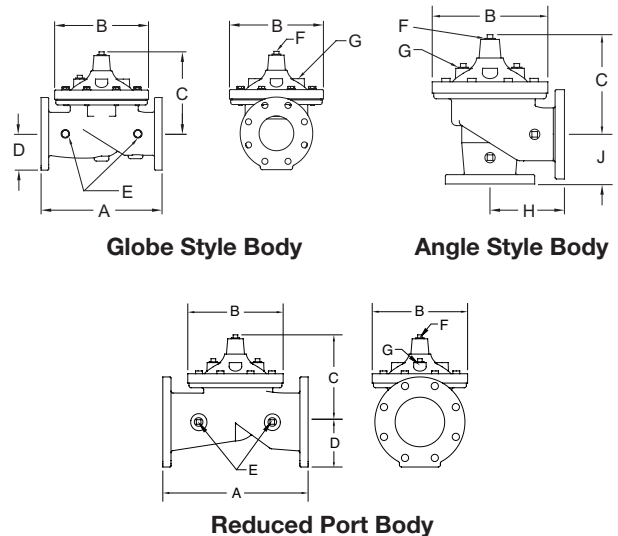

## Operation

The Model ZW209EX utilizes a pressure reducing pilot valve that installs on the discharge side of the control circuitry. The pilot is a direct acting, normally open, spring loaded, diaphragm actuated valve. The operation of the ZW209EX begins with accurately sizing the valve, then fine tuning the control circuit by adjusting the pilot spring to the desired downstream pressure. Inlet pressure is piped to the inlet port of the pressure reducing pilot. A sensing line runs internally from the discharge side of the pilot to its lower control chamber under the diaphragm. Thus, downstream pressure exceeding the preset acts to close the pilot while the adjustable spring seeks to keep it open. The result is a modulating action in the pilot that is transmitted to the bonnet of the main valve. This creates a mirror modulation of the diaphragm assembly in the main valve. Downstream pressure is maintained within narrow limits regardless of changing flow rates or varying inlet pressures.

**Flow Characteristics**

Full Port Globe and Angle Valve size	inches (mm)	1 1/4 (32)	1 1/2 (40)	2 (50)	2 1/2 (65)	3 (80)	4 (100)	6 (150)	8 (200)	10 (250)	12 (300)	14 (350)	16 (400)
Reduced Port Globe Valve Size	inches (mm)			3 (80)		4 (100)	6 (150)	8 (200)	10 (250)				
Suggested Flow (GPM)	Max. Continuous	93	125	210	300	460	800	1800	3100	4900	7000	8400	11000
	Max Intermittent	120	160	260	375	600	1000	2250	4000	6150	8700	10500	13800
	Min. Continuous	10	10	15	20	30	50	115	200	300	435	530	690
Suggested Flow (Liters/sec)	Max. Continuous	6	8	13	19	29	50	113	195	309	550	665	870
	Max. Intermittent	7.6	10	16.4	23	37	62	142	246	388	440	530	95
	Min. Continuous	.6	.6	0.9	1.3	1.9	3.2	7.2	13	19	28	33	43

Suggested flow calculations are based on flow through Schedule 40 Pipe. Maximum continuous flow is approx. 20 ft./sec (6.1 meters/sec) & maximum intermittent is approx. 25 ft./sec (7.6 meters/sec) and minimum continuous flow is approx. 1.25 ft./sec (0.4 meters/sec). Many factors should be considered in sizing pressure reducing valves including inlet pressure, outlet pressure and flow rates.

**Notice:**

In cases where design flow falls below the minimum continuous flow rate, a low flow by-pass shall be installed.

**Typical Installation**

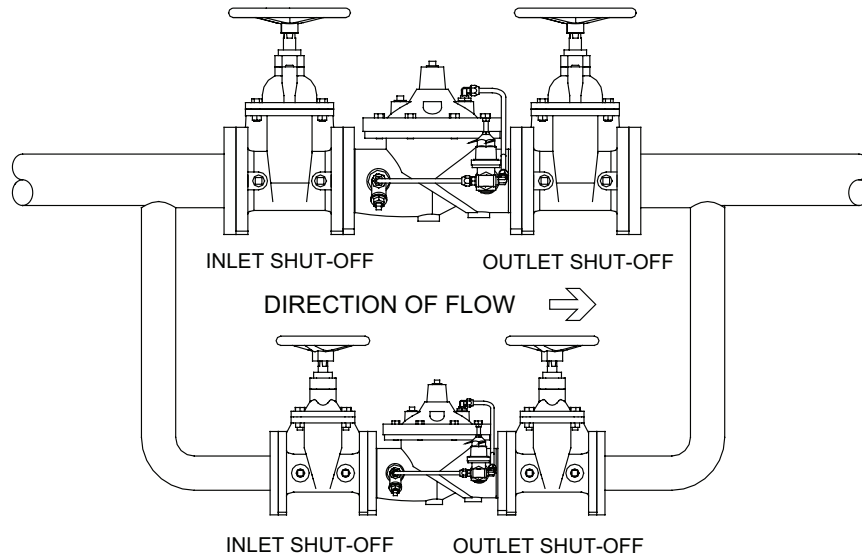

**Notice:**

In cases where design flow falls below the minimum continuous flow rate, a low flow by-pass shall be installed.

**Specifications**

The Pressure Reducing Valve shall be a diaphragm actuated, pilot controlled valve. The main valve body shall be ductile iron ASTM A 536. The stem of the basic valve shall be guided top and bottom. The diaphragm shall not be used as a seating surface. All internal and external ferrous surfaces shall be coated with a high quality, fusion epoxy coating. The pilot control shall be field adjustable from 15 psi to 150 psi. The valve shall be certified to NSF/ANSI 61. The Pressure Reducing Valve shall be a ZURN WILKINS Model ZW209EX.

**Job Name** \_\_\_\_\_

**Contractor** \_\_\_\_\_

**Job Location** \_\_\_\_\_

**Engineer** \_\_\_\_\_

**BODY MINIMUM FRICTION LOSS**

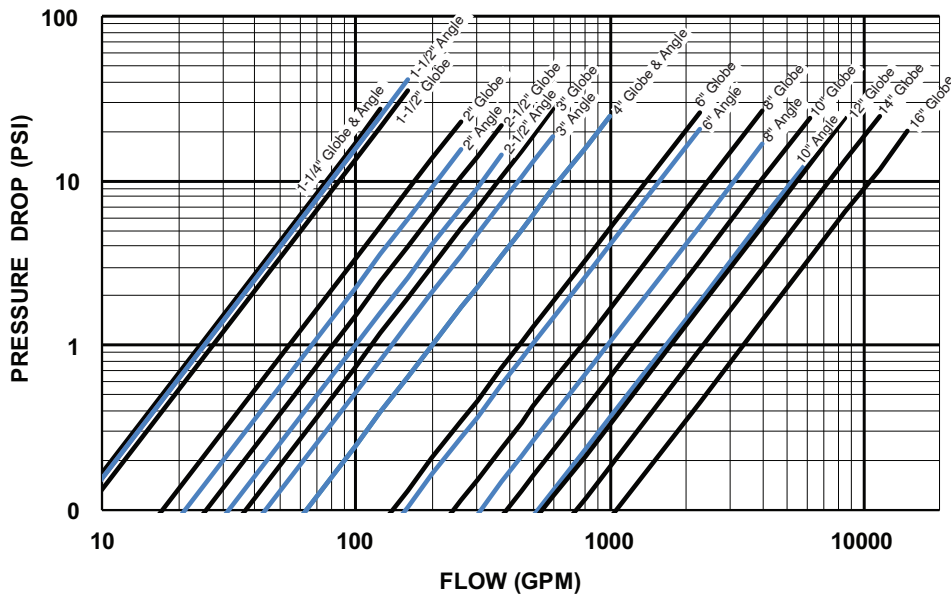

**\* Notes for Body Minimum Friction Loss Chart:**

Minimum inlet pressure is 10 psi higher than set point or the additional body friction loss intended flow, whichever is higher. (friction loss may be important at flows above 20 ft/s)

Example: A 6" valve intended to flow 2000 GPM at 150 psi has a friction loss of 20 psi at 2000 GPM. The minimum inlet pressure would be 150 + 20 = 170 psi. When inlet pressure is below set point, the outlet pressure will be the pressure at the inlet minus the friction loss.

**WATERWORKS PRESSURE REDUCTION LIMIT CHART**

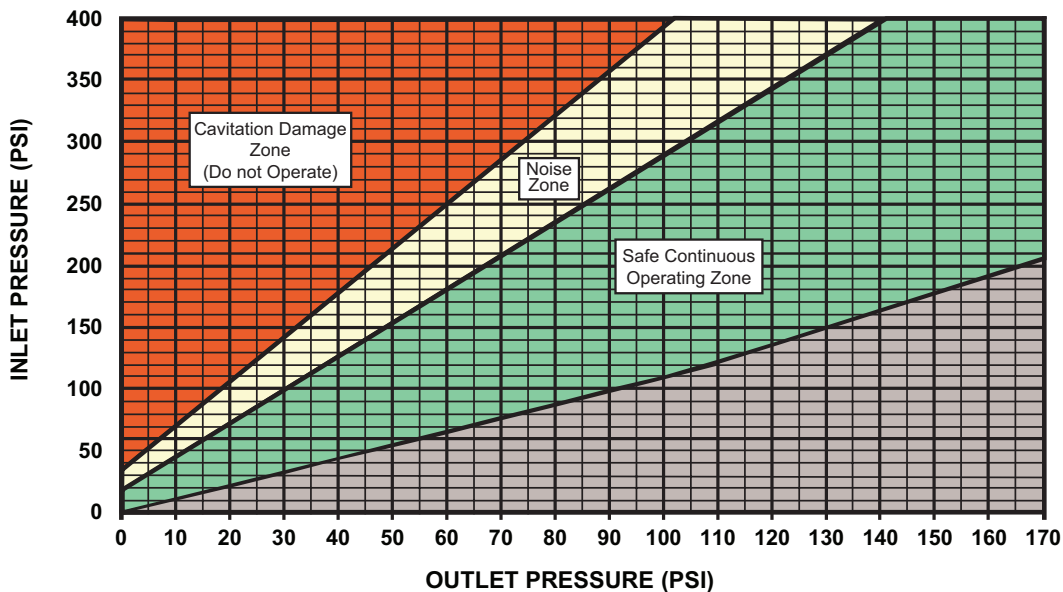

**Notes for Pressure Reduction Limit Chart:** Determine if the outlet reduced flowing pressure is within the safe operating zone for your Zurn Automatic Control Valve. First, find the system inlet pressure on the left axis and draw a horizontal line from that point across the chart. Then find the outlet reduced flowing pressure on the bottom axis and draw a vertical line up to where it meets the first line. The point where the lines intersect should be in the green "Safe Continuous Operating Zone" below and to the right of the yellow "Noise Zone". If the operating point is in the area labeled "Noise Zone" or "Cavitation Damage Zone", the valve seal ring, plunger, or body may be damaged. The lifespan of the valve will be reduced. Damage from cavitation to internal components may cause high pressure downstream and/or external leaks. To move out of the cavitation or noise zone you will need to place two valves in series in order to safely reduce pressure. Use the chart to pick an intermediate pressure in the green zone that you will set the first valve in series to. The intermediate pressure you pick will then become the inlet pressure for the 2nd valve and you can verify it will be in the green zone using the chart.