



# Model ZW218

## Slow Closed Check Valve

### Application

The Zurn Wilkins Model ZW218 Slow Close Check Valve will fully open when inlet pressure is greater than outlet pressure allowing flow. The check valve will close drip tight via the control connected from the outlet to the cover when outlet pressure is greater than the inlet pressure. Opening and closing speed control valves are included with the check valve to prevent surges in the line when the check valve opens and closes. In addition the Model ZW218 comes standard with epoxy coating internally and externally for corrosion protection, as well as isolation valves for quick and easy maintenance or repair.



### Standards Compliance:

ANSI/AWWA C530

• Meets the requirements of NSF/ANSI 61\*

\*(0.25% MAX. WEIGHTED AVERAGE LEAD CONTENT)

### Materials

Main Valve Body	Ductile Iron ASTM A536
Main Valve Bonnet	Ductile Iron ASTM A536
Disc Guide	Stainless Steel
Seat	Stainless Steel
Disc	Buna-N Rubber
Diaphragm	Nylon Reinforced Buna-N
Stem	Stainless Steel
Spring	Stainless Steel

### Schematic Diagram

Item	Description of Standard Features
1	Main Valve
2	Check Valve
3	Closing Speed Control
4	Opening Speed Control

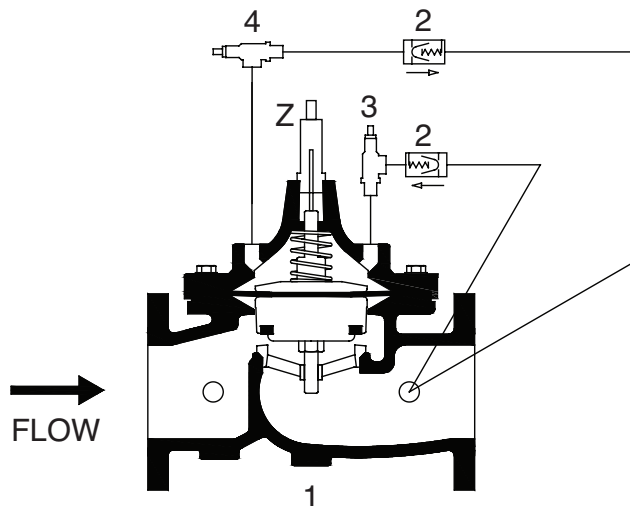

BODY CONFIGURATIONS		GLOBE STYLE BODY		ANGLE STYLE BODY
END CONNECTION	PRESSURE RATING	FULL PORT	REDUCED PORT	
Threaded	400 psi max.	1 1/4"-3"	n/a	1 1/4"-3"
Flanged	ANSI Class 150, 250 psi max.	1 1/2"-16"	3"-10"	1 1/2"-10"
	ANSI Class 300, 400 psi max.			
Grooved	300 psi max.	1 1/2"-10"	n/a	1 1/2"-10"

MINIMUM INLET PRESSURE 10 PSI

TEMPERATURE RATING:  Water 33°F to 140°F

### Standard Features

- Globe Style Body
- Blue Epoxy Coated, FDA Approved
- Pilot Assembly
  - Closing Speed Control
  - Opening Speed Control
- ANSI Class 150 Flanges
- Copper Tubing and Brass Fittings

### Options

(Add suffix letters to ZW218)

#### Body

- A - Angle Style Body
- R - Reduced Port Body

#### Connections

- G - IPS Grooved
- TH - NPT Threaded
- Y - ANSI Class 300 Flanges

#### Main Valve Options

- Z - ZPI Visual Position Indicator

#### Pilot System

- SP - All Stainless Steel Pilotry & Pilot Valve (replaces all brass fittings and copper tubing)
- SH - Stainless Steel Braided Hoses (replaces Copper Tubing)
- SO - Limit Switch Open Trip
- SC - Limit Switch Closed Trip
- SD - Limit Switch Dual Trip

### Globe and Angle Main Valve Dimensions

DIM	FULL PORT	VALVE SIZE INCHES (mm)											
		1 1/4 (32)	1 1/2 (38)	2 (50)	2 1/2 (65)	3 (80)	4 (100)	6 (150)	8 (200)	10 (250)	12 (300)	14 (350)	16 (400)
A	Threaded	7 1/4	7 1/4	9 7/16	11	12 1/2							
	Class 150 Flange		8 1/2	9 3/8	11	12	15	20	25 3/8	29 3/4	34	39	41 3/8
	Class 300 Flange		9	10	11 5/8	13 1/4	15 5/8	21	26 7/16	31 1/8	35 1/2	40 1/2	43 1/2
	Grooved		8 1/2	9	11	12 1/2	15	20	25 3/8	29 3/4			
B	Diameter	5 5/8	5 5/8	6 3/4	8	9 3/16	11 11/16	15 3/4	20 1/8	23 11/16	27 1/2	31 3/4	34 1/2
C	Max.	5 3/4	5 3/4	6 3/16	7 3/8	8	10 3/16	12 5/16	15 9/16	17 5/8	20 3/16	22 13/16	25 7/8
D	Threaded/Grooved	1 3/8	1 3/8	1 3/4	2 1/8	2 9/16	3 7/16	5	5	5 13/16	6 3/4	8 7/8	8 13/16
	Class 150 Flange		2 1/2	3	3 1/2	3 3/4	4 1/2	5 1/2	6 3/4	8	9 1/2	10 1/2	11 3/4
	Class 300 Flange		3	3 1/4	3 3/4	4 1/8	5	6 1/4	7 1/2	8 3/4	10 1/4	11 1/2	12 3/4
E	NPT Body Tap	3/8	3/8	3/8	1/2	1/2	3/4	3/4	1	1	1	1	1
F	NPT Cvr. Plug Tap	1/2	1/2	1/2	1/2	1/2	3/4	3/4	1	1	1	1	1
G	NPT Cover Tap	3/8	3/8	3/8	1/2	1/2	3/4	3/4	1	1	1	1	1
H	Threaded	3 1/4	3 1/4	4 3/4	5 1/2	6 1/4							
	Class 150 Flange		4	4 3/4	5 1/2	6	7 1/2	10	12 11/16	14 7/8			
	Class 300 Flange		4 1/4	5	6	6 7/16	8	10 1/2	13 1/4	15 9/16			
	Grooved		4 7/16	4 3/4	5 1/2	6	7 1/2	10	12 11/16	14 7/8			
J	Threaded	1 15/16	1 15/16	3 1/4	4	4 1/2							
	Class 150 Flange		4	3 1/4	4	4	5	6	8	8 5/8			
	Class 300 Flange		4 1/4	3 1/2	4 5/16	4 7/16	5 5/16	6 1/2	8 1/2	9 5/16			
	Grooved		3 3/16	3 1/4	4	4 1/4	5	6	8	8 5/8			
Valve Stem Internal Thread		10-32	10-32	10-32	10-32	1/4-20	1/4-20	1/4-20	3/8-16	3/8-16	3/8-16	3/8-16	3/8-16
Stem Travel (in)		7/16	7/16	3/4	7/8	1	1 3/16	1 3/4	2 3/8	2 13/16	3 7/16	3 13/16	4 5/16
Approx. Wt. (lbs)		22	26	36	55	70	130	240	440	720	820	1200	1550

### Reduced Port Main Valve Dimensions

DIM		VALVE SIZE INCHES (mm)				
		3" (80)	4" (100)	6" (150)	8" (200)	10" (250)
A	Class 150 Flange	10 1/4	14	17 3/4	21 7/16	26
	Class 300 Flange	11	14 1/2	18 11/16	22 7/16	27 7/16
B	Dia	6 3/4	9 3/16	11 11/16	15 3/4	20 1/8
C	Max	6 3/8	8 7/16	12 5/16	13 1/4	16 3/4
D	Class 150 Flange	3 3/4	4 1/2	5 1/2	6 3/4	8
	Class 300 Flange	4 1/8	5	6 1/4	7 1/2	8 3/4
E	NPT Body Tap	3/8	1/2	3/4	3/4	1
F	NPT Cvr. Plug Tap	3/8	1/2	3/4	3/4	1
G	NPT Cvr. Tap	3/8	1/2	3/4	3/4	1
Valve Stem Internal Thread		10-32	1/4-20	1/4-20	3/8-16	3/8-16
Stem Travel (in)		3/4	1	1 1/5	1 3/4	2 3/8
Approx. Wt. (Lbs)		35	80	140	275	480

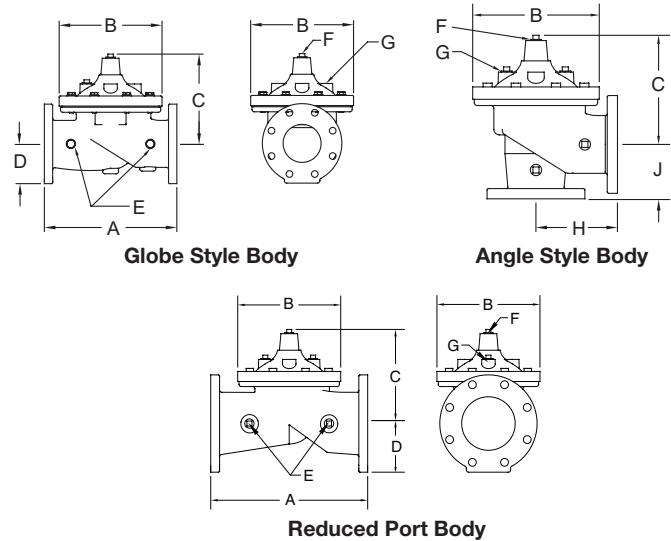

### Pilot System Dimensions

PILOT SYSTEM DIMENSIONS		VALVE SIZE INCHES (mm)											
	DIM	1-1/4 (32)	1-1/2 (40)	2" (50)	2-1/2" (65)	3" (80)	4" (100)	6" (150)	8" (200)	10" (250)	12" (300)	14" (350)	16" (400)
Full Port Body	X Max. (inches)	6 3/8	6 3/8	7	7 3/8	8 1/8	10	12 1/4	15 5/8	17 5/8	20	23	26
	Y Max. (inches)	4 1/4	4 1/4	4 1/2	4 3/4	4 3/4	6	8	10	12	14	16	17 1/2
	Z Max. (inches)	4 1/4	4 1/4	4 1/2	4 3/4	4 3/4	6	8	10	12	17	19	20 1/2
Reduced Port Body	X Max. (inches)					7	8 1/8	10	12 1/4	15 5/8			
	Y Max. (inches)					4 1/2	4 3/4	6	8	10			
	Z Max. (inches)					4 1/2	4 3/4	6	8	10			
Angle Body	X Max. (inches)	6 7/8	6 7/8	7 1/2	8 5/8	8 5/8	10 1/2	12 3/4	16 1/8	18 1/8			
	Y Max. (inches)	4 3/4	4 3/4	5	5 1/4	5 1/4	6 1/2	8 1/2	10 1/2	12 1/2			
	Z Max. (inches)	4 3/4	4 3/4	5	5 1/4	5 1/4	6 1/2	8 1/2	10 1/2	12 1/2			

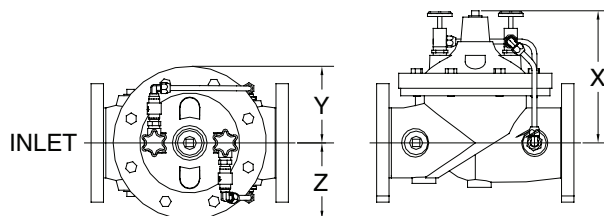

Globe Pilot System Dimensions

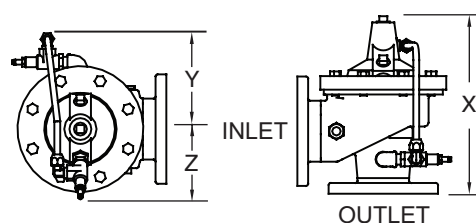

Angle Pilot System Dimensions

**Flow Characteristics**

Full Port Globe and Angle Valve size	inches (mm)	1 1/4 (32)	1 1/2 (40)	2 (50)	2 1/2 (65)	3 (80)	4 (100)	6 (150)	8 (200)	10 (250)	12 (300)	14 (350)	16 (400)
Reduced Port Globe Valve Size	inches (mm)			3 (80)		4 (100)	6 (150)	8 (200)	10 (250)				
Suggested Flow (GPM)	Max. Continuous	27	37	62	88	135	235	535	925	1460	2075	2510	3275
Suggested Flow (Liters/sec)	Max. Continuous	1.7	2.3	3.9	5.5	9	15	34	58	92	130	158	206

**Flow Characteristics**

Note: The flow rate through the slow close check valve affects the performance of the valve. Maximum flow rates based on pipeline velocities of 6 feet per second are recommended. If velocities are higher than 6 feet per second, consideration should be given to adding a Zurn Wilkins ZW205 downstream of the ZW218 discharging to a drain or recirculating to the pump supply to protect the pump from sudden down stream surges.

**Typical Installation**

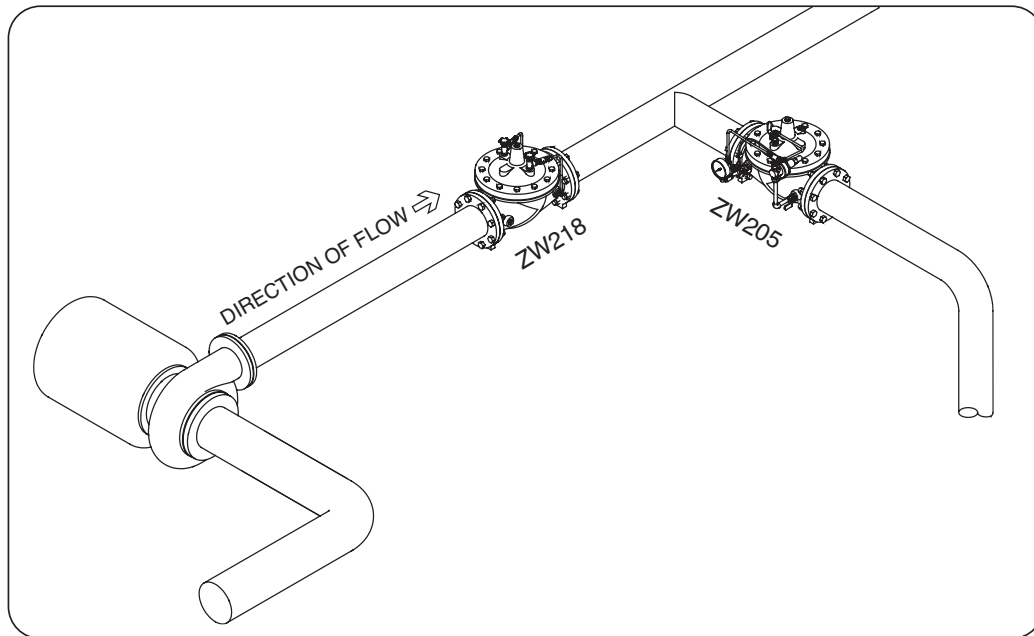

**Specifications**

The Slow Close Check Valve shall be a diaphragm actuated valve supplied with opening and closing speed controls. The main valve body shall be ductile iron ASTM A 536. The stem of the basic valve shall be guided top and bottom. The diaphragm shall not be used as a seating surface. All internal and external ferrous surfaces shall be coated with a high quality, fusion epoxy coating. The valve shall be certified to NSF/ANSI Standard 61. The Slow Close Check Valve shall be a ZURN WILKINS Model ZW218.

Job Name \_\_\_\_\_

Contractor \_\_\_\_\_

Job Location \_\_\_\_\_

Engineer \_\_\_\_\_