



Model FTD Fire Test and Drain

Application

Zurn Model FTD Fire Test and Drain valves provide for required water flow testing and draining of a sprinkler system with one valve. In the test position this valve simulates flow of a single sprinkler with a 5.6 K-Factor orifice. The drain position allows unrestricted flow for rapid draining of the system. Clear sight glass plugs facilitates visual inspection of water flow through the valve.

Standards Compliance

- UL® Listed
- C-UL®
- FM® Approved

Materials

FTD Test and Drain Valve:

Main valve body	Bronze B62
Body Cap Forged	Brass C37700
Ball	Brass ASTM B16 C37700
Stem	Brass B16
Seat	PTFE
Thrust Washer	PTFE
O-Ring	NBR D2000
Gland Packing	PTFE
Indicator Plate	Steel
Gland	Brass B16
Nut	Steel
Handle Cover	PVC Vinyl
Retaining Ring	Brass B16
Washer	Acrylic
O-Ring	NBR D2000
Cap Plug	Brass B16
Sight-glass	PMMA

Features

Sizes:	1", 1 1/4", 1 1/2", 2"
Pressure rating	300 psi
Test K-Factor	5.6 gpm/(psi) ^{1/2} [8.0 L/min(kPa) ^{1/2}]



114-FD-K56

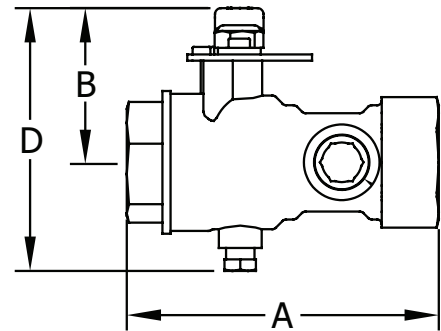
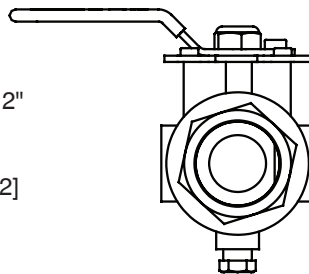
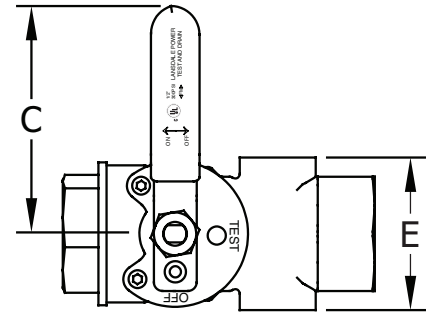

Dimensions & Weights (do not include pkg.)

MODEL	DIMENSIONS (approximate)											
	A		B		C		D		E		WEIGHT	
	in.	mm	in.	mm	in.	mm	in.	mm	in.	mm	lbs	kg.
1-FTD-K56	5 1/8	130	2 7/8	73	5 1/4	133	4 5/8	117	2 1/2	64	2.8	1.3
114-FTD-K56	5 1/8	130	2 7/8	73	5 1/4	133	4 5/8	117	2 1/2	64	2.9	1.3
112-FTD-K56	6 7/8	175	3 3/8	86	6 1/4	157	5 5/8	142	3 5/8	92	6.9	3.0
2-FTD-K56	6 7/8	175	3 1/2	89	6 1/2	165	5 1/2	140	3 5/8	92	7.9	3.6