

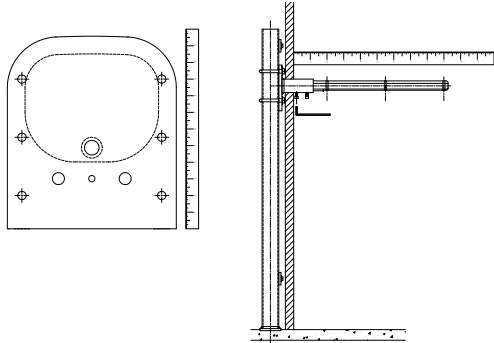

Z1231-EZR

WALL-HUNG LAVATORY CARRIER GENERAL INSTALLATION INSTRUCTIONS

1. Position arms inside of header plate mounting sleeves in accordance to the dimensions provided by the lavatory manufacturer, and secure arms by tightening the (2) set screws on underside of sleeve until snug.



2. Install lavatory lock-down bar to arm by threading it up through the underside of the arm as shown, keeping the wings of the lock-down in line with the arm.

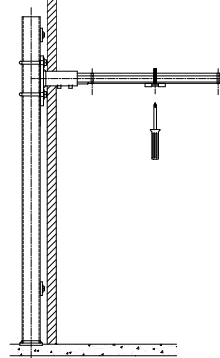

3. Gently slide lavatory onto the carrier arms to within 1/16" of the finished wall. The access holes on the underside of the lavatory should line up with the lockdown bar & adjustment screw holes of the arms.

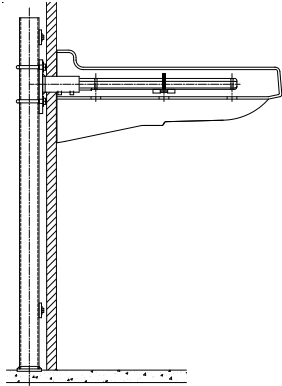

4. To make adjustments to the height and level of the lavatory, install the remaining (4) leveling screws by threading each screw up through the underside of the lavatory into the carrier arms, raising or lowering the fixture as necessary.

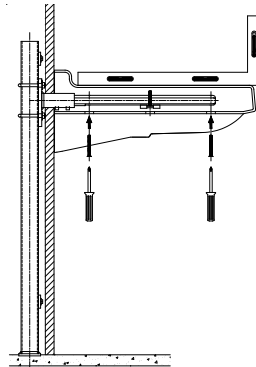

5. Once the lavatory is set to the proper height and leveled, gradually reverse the lock-down bar screw from the arm until the rubber pads of the lock-down make contact with the fixture, securely locking it into place.

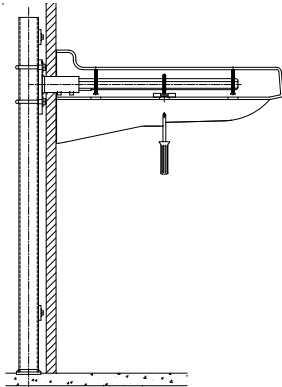

6. Caulk/Silicone lavatory to the finished wall for a water tight seal.

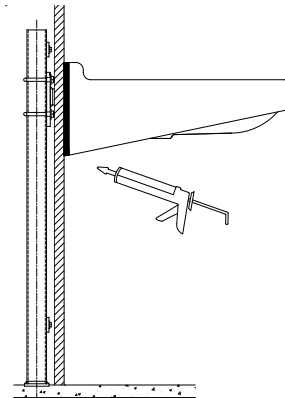

⚠ WARNING: Cancer and Reproductive Harm - www.P65Warnings.ca.gov
⚠ ADVERTENCIA: Cáncer y daño reproductivo - www.P65Warnings.ca.gov
⚠ AVERTISSEMENT: Cancer et effets néfastes sur la reproduction - www.P65Warnings.ca.gov