



# ZP6800 Series

Concealed Flush Valves

Installation, Operation, Maintenance  
and Parts Manual

Patented and Patents Pending



## ZP6800 Series

Concealed Piezo Activated Flushometer for Penal Fixtures

**ZP6800 Series Water Closet Models can be furnished for the following:**

- HET-NES 1.28 gpf [4.8 Lpf] High Efficiency Flush
- WS1-NES 1.60 gpf [6.0 Lpf] Low Consumption Flush

**ZP6800 Series Water Closet Models can be powered by the following:**

- BATT 3 year Battery
- LL 10 year Long Life Battery
- AC Hardwired to 24 VAC 60hz
- DC Hardwired to 7.6 VDC

**⚠ WARNING:** Cancer and Reproductive Harm - [www.P65Warnings.ca.gov](http://www.P65Warnings.ca.gov)

**⚠ ADVERTENCIA:** Cáncer y daño reproductivo - [www.P65Warnings.ca.gov](http://www.P65Warnings.ca.gov)

**⚠ AVERTISSEMENT:** Cancer et effets néfastes sur la reproduction - [www.P65Warnings.ca.gov](http://www.P65Warnings.ca.gov)

### LIMITED WARRANTY

All goods sold hereunder are warranted to be free from defects in material and factory workmanship for a period of three years from the date of purchase. Decorative finishes warranted for one year. We will replace at no costs goods that prove defective provided we are notified in writing of such defect and the goods are returned to us prepaid at Sanford, NC, with evidence that they have been properly maintained and used in accordance with instructions. We shall not be responsible for any labor charges or any loss, injury or damages whatsoever, including incidental or consequential damages. The sole and exclusive remedy shall be limited to the replacement of the defective goods. Before installation and use, the purchaser shall determine the suitability of the product for his intended use and the purchaser assumes all risk and liability whatever in connection therewith. Where permitted by law, the implied warranty of merchantability is expressly excluded. If the products sold hereunder are "consumer products," the implied warranty of merchantability is limited to a period of three years and shall be limited solely to the replacement of the defective goods. All weights stated in our catalogs and lists are approximate and are not guaranteed.

**IMPORTANT:**

- All plumbing is to be installed in accordance with applicable codes and regulations.
- Water supply lines must be sized to provide an adequate volume of water to each fixture.
- Flush all water lines prior to valve installation to ensure proper operation.
  - Particulates in the water can block small orifices within the valve which may result in continuous running.
- Do not use toothed tools during installation or service of the flush valve or its components.

**WARNING:** Batteries can explode or leak and cause burns if installed backwards, disassembled, charged, or exposed to water, fire or high temperature. Do not mix alkaline with lithium batteries.

**Prior to Installation:**

Before installing Zurn® concealed flushometer valves, the following items should already be installed on site:

- Water Closet and/or Combination Fixture
- Drain Line
- Water Supply Line
- Control Stop Assembly

The following tools may be necessary for installation:

- Non-toothed Wrench
- Phillips Head Screwdriver
- Pipe Cutters
- 5 Gallon Bucket
- Cleaning Rag
- Utility Knife
- Tape Measure
- Channel Locks
- Hacksaw or Sawzall
- Allen Wrench (M3)
- Adjustable Wrench
- Standard Wrench (M11)

The ZTR valve operates optimally between 35 and 80 psi water pressure (running). The minimum pressure required for the valve to work properly is determined by the fixture selected. Please consult fixture manufacturer for pressure requirements.

**Step 1: Attach Flush Valve to Control Stop Assembly**

1.1) Ensure the O-ring seal is located in the O-ring seal groove at the end of the tailpiece and the locking nut and locking snap-ring are located as shown.

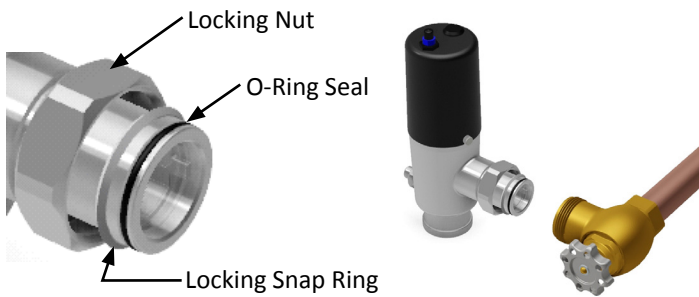

NOTE: Care should be taken not to damage the O-ring when inserting the tailpiece into the control stop. Wetting the O-ring with water should provide sufficient lubrication and easier installation without pinching/damaging the O-ring.

1.2) Insert Tailpiece into control stop and tighten tailpiece coupling nut by hand.

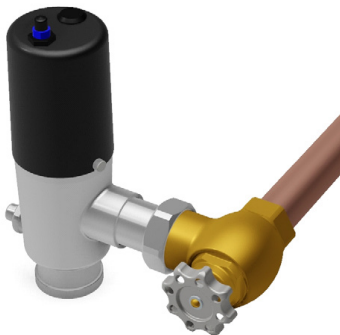

**Step 2: Connect Flush Valve to Vacuum Breaker Tube**

NOTE: This step assumes that the appropriate tubing has already been measured, modified, and assembled according to the Tube Configuration for Concealed Flush Valves O&M.

2.1) Insert the vacuum breaker into the vacuum breaker tube and align the valve with the tube.

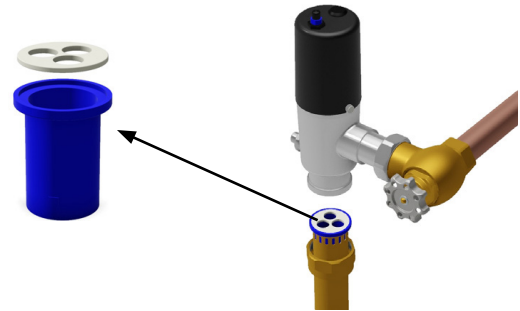

2.2) Connect the flush valve to the vacuum breaker tube using the vacuum tube nut and tighten securely using non-toothed wrench.

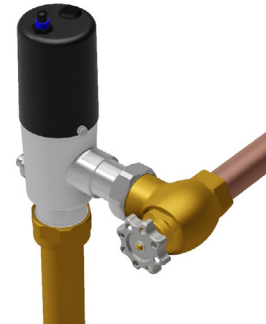

**Step 3: Connect Valve to Power Supply**

3.1) Battery Version (-BATT) or Lithium Version (-LITH)

3.1.1) Loosen the thumb screws and remove the cap from the main valve body.

NOTE: It is not necessary to completely remove the thumb screws since the cap is slotted.

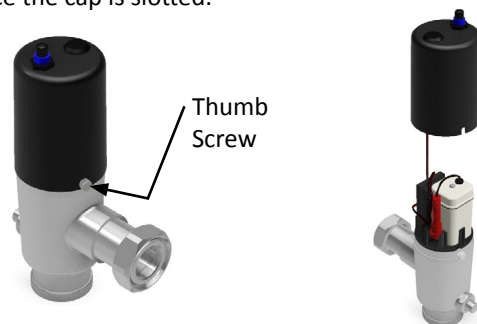

3.1.2) Remove the top of the sealed battery housing with a Phillips head screwdriver.

NOTE: Ensure the small O-ring on the screw is not lost during removal of the housing top.

3.1.3) Insert the 4 AA batteries (Alkaline or Lithium) into the housing and reattach the top. Ensure the batteries are inserted in the proper orientation or the valve will not function properly. [See warning on Page 2]

3.1.4) Place the battery housing back into its designated area. Orient the housing with the grommet away from the connector positioner.

3.1.5) Connect the battery housing to the RED connector and position the mated connectors into the extrusion as shown.



Connector Positioner

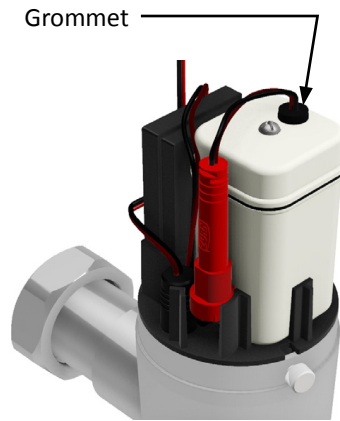

3.1.7) Reattach the cap and tightly secure the thumb screws by hand.

### 3.2) DC Version (-DC)

NOTE: The ZP6800-DC version requires 7.6VDC power input provided by either the HW6 or AC Adapter. Please refer to each power supply O&M for detailed installation instructions. For simplified installation it is recommended that the Power Junction Box be used in conjunction with either power supply.

NOTE: The HW6 can provide power for up to 8 valves, while the AC Adapter can power up to 4 valves.

3.2.1) Connect one end of the 10' DC Power Supply Cable into the RED connector on the valve cap.

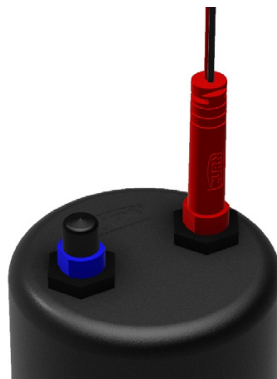

3.2.2) Connect the other end of the 10' DC Power Supply Cable into a RED connector on the Power Junction Box. Refer to detail schematic.

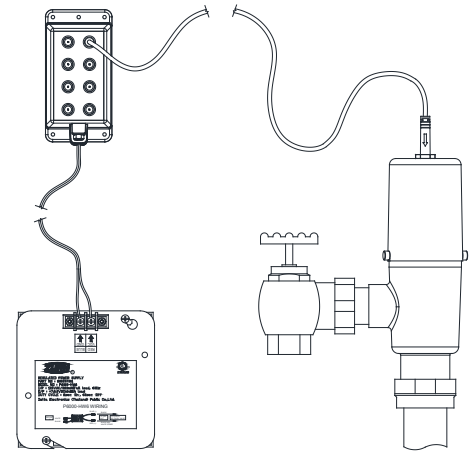

ZP6800-DC POWERED BY HARDWIRED HW6

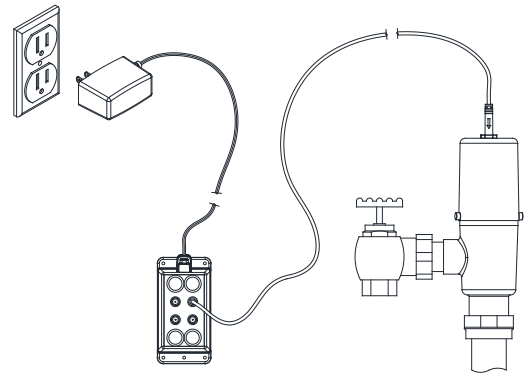

ZP6800-DC POWERED BY PLUG-IN AC ADAPTER

### 3.3) AC Version (-AC)

NOTE: The ZP6800-AC version requires 24 VAC 60hz power input provided by an AC Transformer. Please refer to the power supply O&M for detailed installation instructions. For simplified installation it is recommended that the Power Junction Box be used in conjunction with the power supply.

NOTE: An overmolded power interface module will be located within the cap and should already be connected to the control board. This will regulate the 24VAC to 7VDC.

3.3.1) Connect the GREY end of the 10' AC Power Supply Cable into the GREY connector on the valve cap.



3.3.2) Connect the other end of the 10' AC Power Supply Cable into a RED connector on the Power Junction Box. Refer to detail schematic.

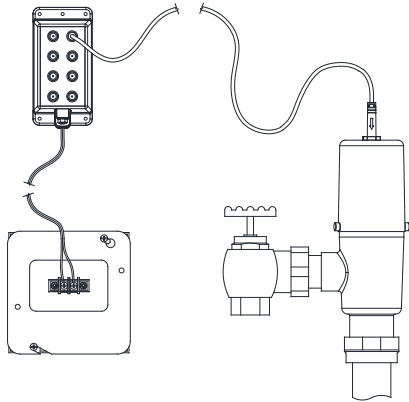

ZP6800-AC POWERED BY  
HARDWIRED AC TRANSFORMER

**Step 4: Install Piezo Switch**

**NOTE:** The piezo pushbutton switch may be secured to walls or combination fixtures. It fits thru holes up to 1-1/2" diameter when an escutcheon is used, and also fits standard cutouts typically found on combination fixtures.

**NOTE:** This step applies to all power versions.

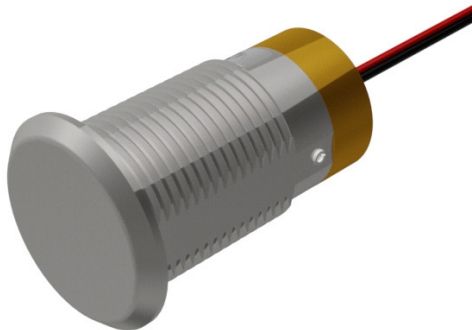

4.1) Pass the BLUE piezo button connector through the front side of the wall or combination fixture. If necessary, use the stainless steel escutcheon for thru holes up to 1-1/2" diameter.

4.2) If accessible, pass the BLUE connector through the locking nut and securely tighten to the piezo button.

4.3) Apply a bead of Loctite to the end of the threaded rod assembly and secure to the brass insert in the back of the piezo button.

4.4) Remove the first nut and washer from the threaded rod assembly. Position the support bar along the rod until it contacts the wall surface. The support bar may be oriented based on wall thickness, for example:

- For thinner walls, orient the support bar where the prongs are facing towards the wall.
- For thicker walls, orient the support bar where the prongs are facing away from the wall.

4.5) Reattach the washer and nut to the threaded rod and securely tighten the support bar to the wall or combination fixture.

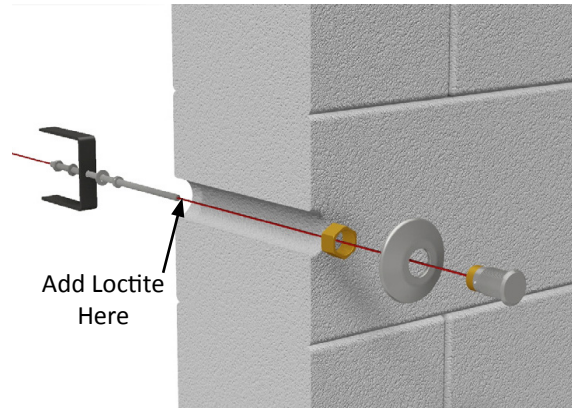
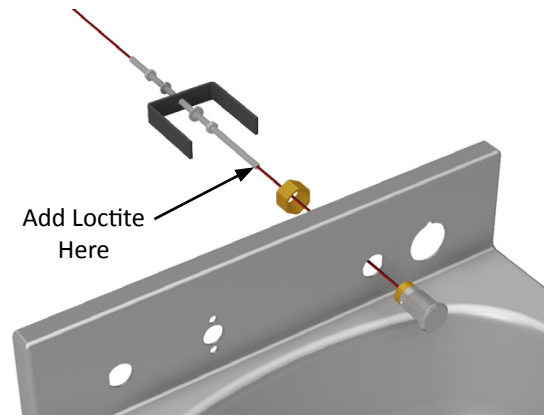

4.6) Connect the piezo switch to the BLUE connector on the valve cap.

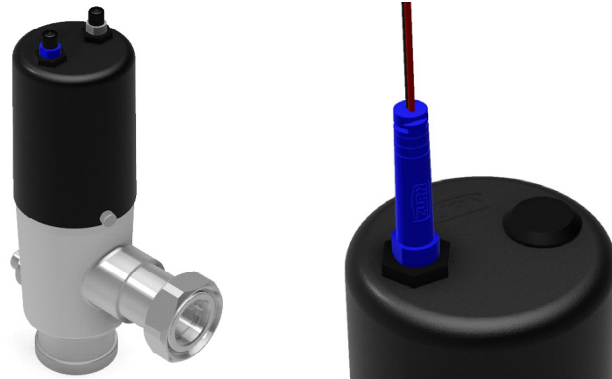

**Step 5: Turn on water at the control stop and activate a flush by pressing the piezo button.**

**Adjustable Features**

The ZP6800 flush valve comes preset for lockout setting, flow volume, and courtesy trapseal flush. Each valve is factory tested using water to ensure proper function prior to shipment. These features may be field adjusted using the dipswitch located on the control board.

To access the control board simply remove the cap by loosening the thumb screws. It is not necessary to completely remove the screws since the cap is slotted.

The control board will be oriented upright and positioned in its designated slot, as shown below. The dipswitch is located in the upper-right hand corner of the control board and includes 8 switches.

The switch is OFF when positioned towards the numbers on the dipswitch. The switch is ON when positioned away from the numbers.

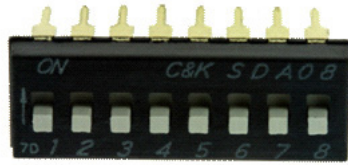

Close up of Dip switch

### Lockout Adjustments

This feature is used to reduce inmate abuse of valuable water resources and hampers nuisance flooding.

Lockout may be based on specific facility needs and/or purpose, for example:

- Lockout may be disabled for dorm areas or medical wards.
- Lockout may be enabled for intake areas, individual cells, high security areas, or cells with occupants who are known to abuse flushing privileges.

Four settings are available by adjusting Switches 2 & 3.

Lockout	Feature	#2	#3
Lockout #1	Lockout feature disabled	OFF	OFF
Lockout #2	Valve disabled for 1 hour if user flushes valve 2 times within 5 minutes	OFF	ON
Lockout #3	Valve disabled for 1 hour if user flushes valve 3 times within 5 minutes	ON	OFF
Lockout #4	Valve disabled for 1 hour if user flushes valve 4 times within 5 minutes	ON	ON

### Flush Volume Adjustments

This feature is used to make flush volume adjustments to ensure maximum evacuation performance with minimal water usage based on a facility's specific environment.

For retrofit applications onto 3.5 GPF fixtures, flow volume adjustments can be made to optimize performance while yielding water usage savings.

Consult factory for additional information.

### 96-hour Courtesy Flush

This feature provides a sentinel flush to refill toilet traps in cells that may be empty/inactive for long periods of time resulting in a more sanitary holding facility.

For medical wards, it ensures that the water has not been stagnant for excessive periods of time and prevents bacteria growth. Providing a courtesy flush keeps the water "fresh".

To enable 96-hour Courtesy Flush set Switch 8 to ON.

For Trouble Shooting Guide - See pg 6

### Accessing Piston Kit

1.) Remove valve cap and base to expose solenoid. Using M3 Allen wrench remove the six screws and the solenoid flange.



2.) Remove the piston kit from the valve body and inspect for damage to the seals or debris in the orifice. Excessive build up of debris may occur on filter screen.

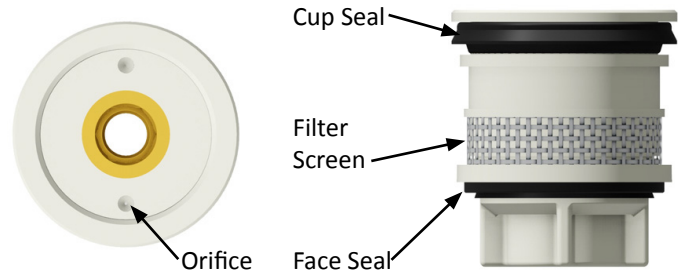

### Accessing Solenoid

1.) Unscrew the solenoid from the flange and remove the rubber diaphragm.

2.) Inspect the plastic orifices for debris and clean. If necessary, peel back the rubber from the plastic piece to reveal the rubber orifices and inspect for debris.



## TROUBLESHOOTING GUIDE

Problem	Indicator	Cause	Solution
Valve does not flush	Pressing piezo button does not activate flush	Piezo button damaged	Replace piezo button switch
		Piezo button not connected to valve	Connect the piezo button to the valve via the <b>BLUE</b> connector (Refer to Step 4)
		Solenoid damaged	Replace solenoid assembly
		Stuck solenoid plunger	Remove solenoid – inspect, repair, and clean plunger. Ensure spring is vertical. Use scale removal material if needed.
		Solenoid not connected to Main Control Board	Connect solenoid to the Main Control Board via the <b>BLACK</b> connector
		Power not supplied to valve (hard-wired versions)	Connect power supply cable to the valve via the <b>RED</b> or <b>GREY</b> Connector
			Connect power supply cable to Power Junction Box via the <b>RED</b> Connector
		Main Control Board damaged	Replace Main Control Board
		Water supply line closed	Open water supply line at the control stop
		Valve has entered “Lockout Mode”	Wait 1-hr for the lockout feature to be reset
			Electrically short the Main Control Board
		Batteries not installed	Install batteries into sealed battery housing
		Batteries installed backwards	Remove batteries and install correctly
Pressing piezo button does not activate flush and <b>RED</b> LED on Main Control Board is flashing	Battery voltage level too low to activate full flush	Replace batteries. (Refer to Step 3.1 for battery installation instructions)	
Pressing Manual Override Button (MOB) does not activate flush	MOB damaged	Replace MOB	
Valve does not shut off	Water continues to flow after flush activation using piezo button	Water pressure either too high or too low	Adjust water pressure to recommended operating pressure range of 35-80 psi (running)
		Clogged orifice in solenoid diaphragm	Remove solenoid – inspect rubber diaphragm for clogged holes, then clear the holes and reassemble solenoid into valve
		Stuck solenoid plunger	Carefully remove solenoid from flange. Inspect and clean plunger. Ensure spring is vertical. Use scale removal material if needed.
		Debris in solenoid plunger	
		Damaged piston kit cup seal or face seal	Replace piston kit
		Clogged orifice in piston kit	Remove piston kit from valve body. Inspect for debris and clean as needed.
		Debris on piston kit cup seal or face seal	
	Water continues to flow after flush activation using MOB	MOB damaged / leaking	Replace MOB
Water continues to flow after valve installation	Stuck solenoid plunger	Activate flush using piezo button.	



## ZP6800 Series Parts Breakdown

### Parts Identification

1. Jam Plug
2. Jam Nut
3. Cap
4. Gasket
5. Control Board Assembly
6. Cap Base
7. Solenoid Assembly
8. Solenoid Flange Screw
9. Solenoid Flange
10. Piston Kit Assembly
11. Cap Screw
12. ZP Valve Body
13. Manual Override Button
14. Tailpiece Filter
15. Power Interface Module <sup>1</sup>
16. Battery Box <sup>2</sup>
17. Alkaline Batteries <sup>3</sup>
18. Lithium Batteries <sup>4</sup>
19. Piezo Button
20. Stainless Steel Escutcheon
21. Spacer Nut
22. Piezo Button Assembly
23. Stud
24. Nut
25. Lock Washer
26. Washer
27. Support Bar
28. Wall Anchor Assembly

1. -AC Version Only
2. -Batt or -LL Version Only
3. -Batt Version Only
4. -LL Version Only

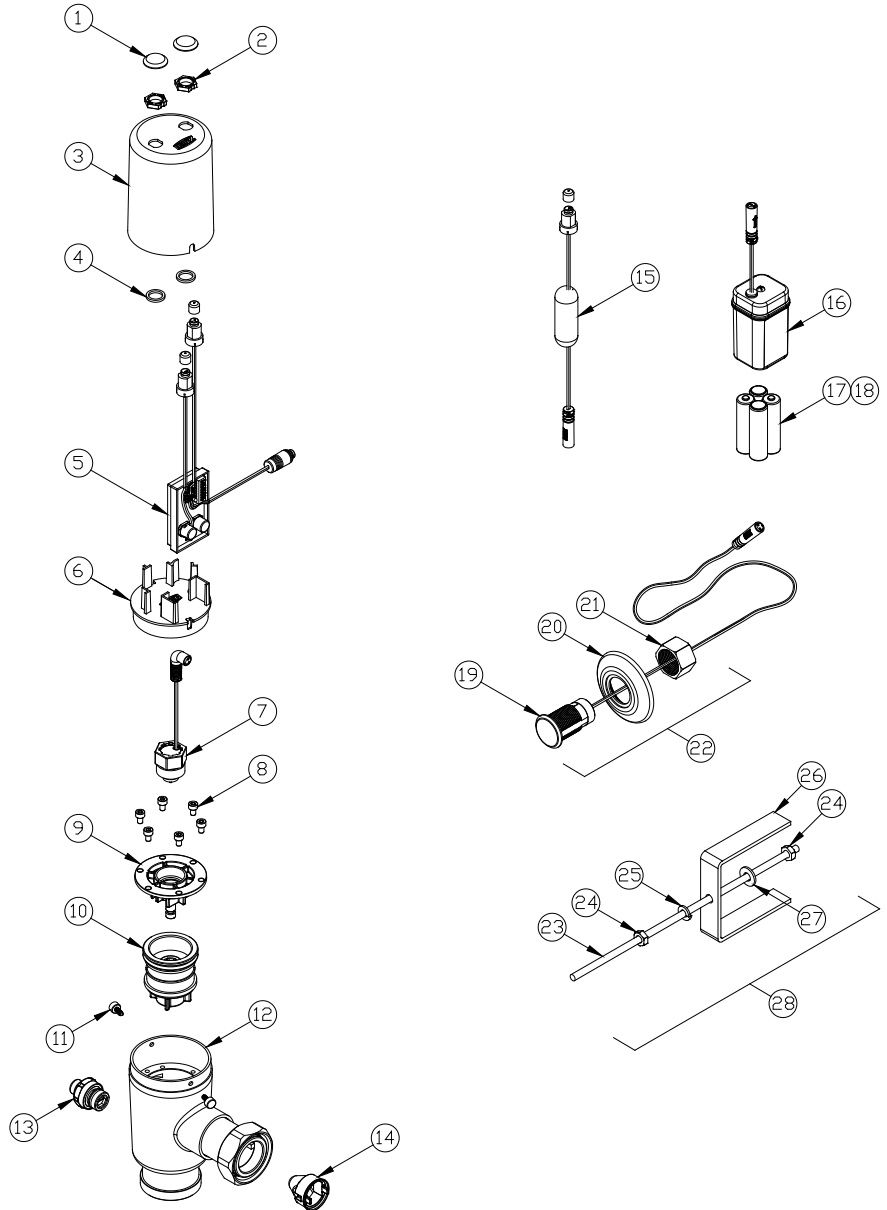

Valve and Components	Product No.
Valve Housing, Items 12 & 13	PP6800-HAS
Solenoid, Item 7	PP6800-SO
Piston Kit Item 10	PP6800-EC
Manual Override Button Assembly, Item 13	PP6800-24
Tailpiece Filter, Item 14	P6000-FA
Piezo Button, Item 19	PP6800-PZ
Electronics Assembly, Item 5	PP6800-EL

AquaSense® is a registered trademark of Zurn Industries, LLC.  
Printed in the U.S.A.

