

Product information presented here reflects conditions at time of publication. Consult factory regarding discrepancies or inconsistencies.

**PUMP COMPANY**

Zoeller Family of Water Solutions™

MAIL TO: P.O. BOX 16347 • Louisville, KY 40256-0347  
 SHIP TO: 3649 Cane Run Road • Louisville, KY 40211-1961  
 (502) 778-2731 • 1 (800) 928-PUMP • FAX (502) 774-3624

visit our web site:  
[www.zoeller.com](http://www.zoeller.com)

## DISCONNECT & RAIL SYSTEMS

- Economical, reduces time & cost of removing pump.
- Safety, keeps personnel out of pits & out of contact with contaminants.
- Inspections made fast & easy.

### DISCONNECT ONLY (1¼", 1½" & 2" Discharge)

Disconnect Fitting; used for shallow systems where guide rails are not necessary. (pull rod not included)

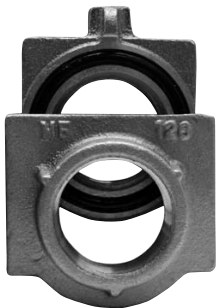

39-0053, 1¼" NPT  
 39-0001, 1½" NPT  
 39-0002, 2 NPT

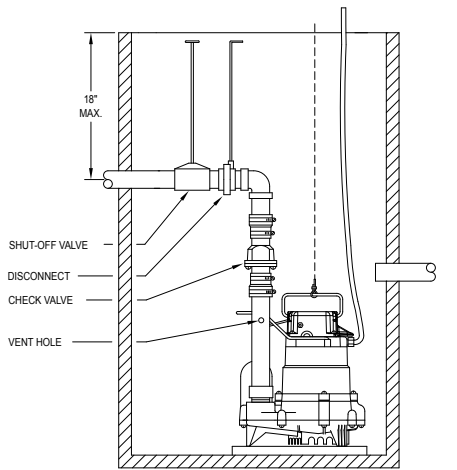

SK730

### COMPLETE SYSTEMS (1½" & 2" Discharge)

Rail & Disconnect System for Effluent or Sewage Pumps for removal and reinstallation of pumps without getting in or removing fluid from the pit. (2 Standoffs included)

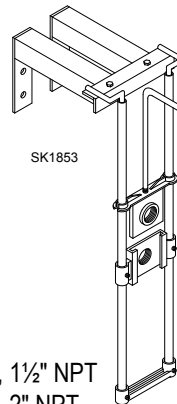

SK1853

39-0003, 1½" NPT  
 39-0004, 2" NPT  
 Pipe rails, pull rods and intermediate brackets not included.

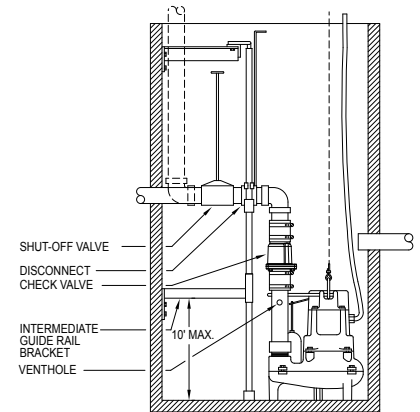

SK731

SPECIFICATIONS					
Part Number	39-0053	39-0001	39-0002	39-0003	39-0004
Pipe Size	1¼" NPT	1½" NPT	2" NPT	1½" NPT	2" NPT
Disconnect Material	Brass	Brass	Brass	Brass	Brass
Disconnect Weight	1.6 lbs.	2.0 lbs.	2.5 lbs.	10.1 lbs.	12 lbs.
Centerline of Rails From Wall-In 30" Basin (Minimum)	-----	-----	-----	2.75"	2.75"
Travel to Disengage	3¾"	3"	3½"	3-3/8"	3-7/8"
Pressure Rating	150 PSI	150 PSI	150 PSI	150 PSI	150 PSI
Pull Rods Thread size	3/8" - 16 UNC	3/8" - 16 UNC	3/8" - 16 UNC	3/8" - 16 UNC	3/8" - 16 UNC
Support Weight	All pumps should be supported underneath with concrete blocks or basin floor.				
Guide Rail Size & Material	---	---	---	¼" IPS Pipe (S.S./Gal.) (recommended) or PVC Scd. 80 (optional). Supplied by customer.	

Intermediate Guide Rail Bracket  
 One Intermediate Guide Rail Bracket is required for every 10 feet of rail.  
 Use 39-0022 with 39-0003 & 39-0004.

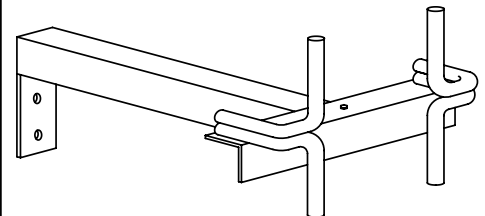

SK1260

39-0022

# SQUARE GUIDE RAIL SYSTEMS (1¼", 1½" & 2" Discharge) FIELD ASSEMBLED

- Economical, reduces time & cost of removing pump.
- Safety, keeps personnel out of pits & out of contact with contaminants.
- Inspections made fast & easy.

## FEATURES

- Single rigid stainless steel square rail design.
- Stainless steel rail, nuts, bolts, fasteners and lifting bail.
- Cast Iron angle arm bracket and pump guide bracket.
- Galvanized piping. Stainless steel - optional.
- Red brass disconnect fittings with Teflon coated Buna O-ring seal.
- PVC Ball Valve
- Cast Iron Check Valve
- Optional stainless steel pull rods and lifting cable available.
- Also available in prepackaged fiberglass basins

\* For tanks deeper than 72" a second angle arm bracket P/N 39-0070 is required. Sch. 40 galvanized or stainless steel pipe is used for extending the rail length.

Rail System	*Tank Depth	Discharge Pipe size	Pump Series
39-0054	48"	1 ¼"	840
39-0055	60"	1 ¼"	840
39-0056	72"	1 ¼"	840
39-0057	48"	1 ¼"	820
39-0058	60"	1 ¼"	820
39-0059	72"	1 ¼"	820
39-0060	48"	1 ½"	160/4160-180/4180 Effluent Pumps
39-0061	60"	1 ½"	160/4160-180/4180 Effluent Pumps
39-0062	72"	1 ½"	160/4160-180/4180 Effluent Pumps
39-0063	48"	2"	160/4160-180/4180-290/4290 Effluent & Sewage Pumps
39-0064	60"	2"	160/4160-180/4180-290/4290 Effluent & Sewage Pumps
39-0065	72"	2"	160/4160-180/4180-290/4290 Effluent & Sewage Pumps
39-0066	48"	2"	280/4280 Sewage Pumps
39-0067	60"	2"	280/4280 Sewage Pumps
39-0068	72"	2"	280/4280 Sewage Pumps

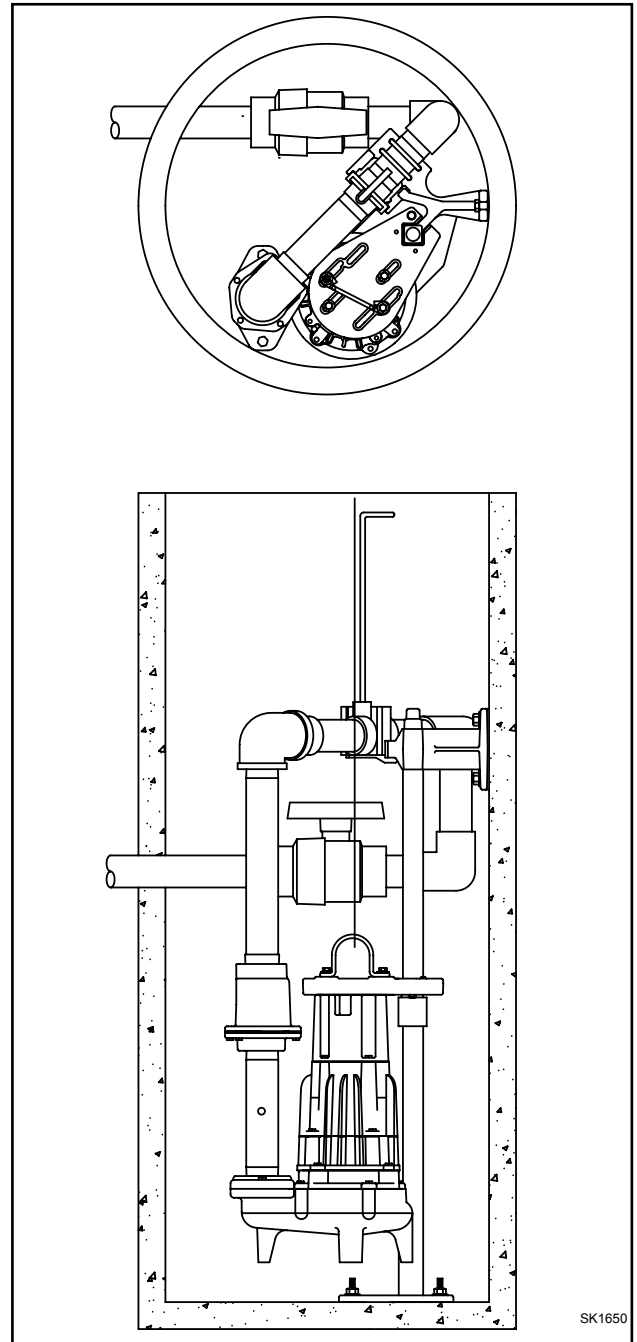

005264

**Stainless Steel Pull Rods**

3/8"-16 UNC	
Part Number	Length
39-0069	1'
39-0006	2½'
39-0007	3½'
39-0008	4½'
39-0009	5½'
39-0018	7'
39-0010	8'

SKA1335

**Stainless Steel Lifting Cable**

Part Number	Length
39-0031	8'
39-0032	12'
39-0033	16'
39-0034	20'
39-0035	24'

# E-Z OUT RAIL SYSTEMS (1¼", 1½"- 3" NPT Discharge Pumps)

## FEATURES

- Sewage, storm water and effluent pump systems.
- For concrete, steel, or fiberglass tanks.
- Allows for removal of pumps from ground level.
- No confined space entry to service pump.
- No pull rods or hold down rods.
- No diaphragms.
- Cast iron base elbow and positive machine fit with o-ring seal provides a reliable seal.
- Designers liability can be reduced by providing reasonable care in the design of submersible pump installations. Pumps are removable from above pump for inspection and service.
- Guide rails direct the pump to and from the base elbow. Systems are supplied complete with base elbow, sealing plate, pump discharge elbow, and upper rail bracket.
- All systems use ¾" schedule 40 pipe rails (not included).

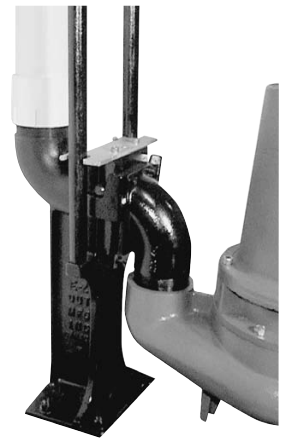

**3" Vertical E-Z Out**  
**Patent # 5,507,628**

### P/N 10-2315 & 10-2316

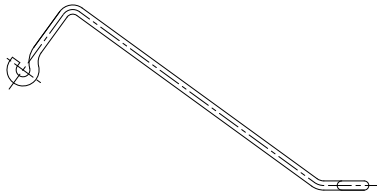

SK2697

A lifting bail is required for the following models to balance the pump and rail plate evenly:

#10-2315 for 50, 90 and 150 series pumps

#10-2316 for 130, 140, 260 and 270 series pumps

#10-0789 for 160, 180, 280, 290, 810/815 and 820 series pumps.

Other models already include proper lifting device.

### P/N 10-0789

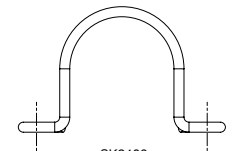
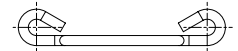

SK2486

## SPECIFICATIONS

Rail System	Pump Discharge	Rail System Discharge	Materials of Construction*	Weight
39-0087	1 ¼" V	2" V	Cast Iron / Steel / Galvanized Steel	43
39-0088	1 ¼" V	2" V	Cast Iron / Steel / Stainless Steel	43
39-0101	1 ¼" V	2" V	Cast Iron / Brass / SS / Brass for Non-sparking	43
39-0115***	1 ¼" H	1 ¼" V	Cast Iron / Steel / Galvanized Steel (810/815 Only)	43
39-0116***	1 ¼" H	1 ¼" V	Cast Iron / Steel / Stainless Steel (810/815 Only)	43
39-0085	1 ½" V	2" V	Cast Iron / Steel / Galvanized Steel	43
39-0086	1 ½" V	2" V	Cast Iron / Steel / Stainless Steel	43
39-0092	1 ½" V	2" V	Cast Iron / Brass / SS / Brass for Non-sparking	45
39-0083	2" V	2" V	Cast Iron / Steel / Galvanized Steel	45
39-0084	2" V	2" V	Cast Iron / Steel / Stainless Steel	45
39-0093	2" V	2" V	Cast Iron / Brass / SS / Brass for Non-sparking	47
39-0074	3" V	3" V	Cast Iron / Steel / Galvanized Steel	55
39-0075	3" V	3" V	Cast Iron / Steel / Stainless Steel	55
39-0076	3" V	3" V	Cast Iron / Brass / SS / Brass for Non-sparking	57

## ACCESSORIES

*Intermediate rail brackets are required for each 12' of basin depth.*

39-0089	Intermediate rail bracket 1¼", 1 ½" and 2" discharge - Galvanized Steel	6
39-0090	Intermediate rail bracket 1¼", 1 ½" and 2" discharge - Stainless Steel	6
39-0079	Intermediate rail bracket 3" discharge - Galvanized Steel	6
39-0080	Intermediate rail bracket 3" discharge - Stainless Steel	6
10-2315**	SS lifting bail for 50, 90 & 150 Series	1
10-2316**	SS lifting bail for 130, 140, 260 & 270 Series	1
10-0789**	SS lifting bail for 160, 180, 280, 290, 810/815 and 820 Series	1

\*Coupling Base / Sealing Plate / Upper Support / Guide Plate.

\*\*Lifting bails are required on these models to balance pump and rail plate evenly. Other models already include proper lifting device.

\*\*\*Tested for use to 220 feet total dynamic head. Applications exceeding this should use Zoeller square rail, flexible discharge hose or rigid piping.

# RAIL SYSTEMS (3" & 4") - FIELD ASSEMBLED

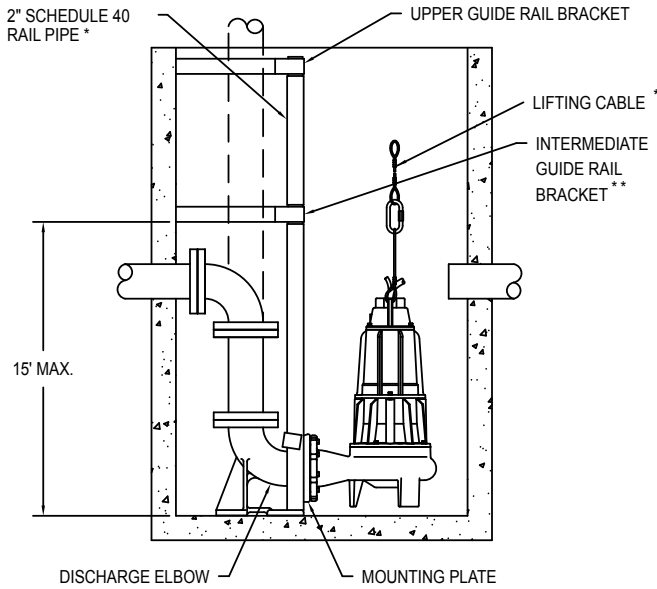

ZEPA0304

\* Not Included

\*\* One Intermediate Guide Rail Bracket is required for every 20 ft. for 3" System or 15 ft. for 4" System, of basin depth. See chart for part number.

Guide Rail System is for removal and installation of flanged horizontal discharge pumps without getting in or removing fluid from pit.

SPECIFICATIONS			
Part Number	Description	Pump Discharge	Guide Rails*
39-0094	3" Guide Rail System S.S.	3" Horizontal Flange	2" S.S. or Galv.
39-0016	4" Guide Rail System S.S. Flange	4" Horizontal	2" S.S. or Galv.
39-0095	3" Guide Rail System S.S. Non-Sparking for Class 1 Group C and/or Group D Division 1 Installation	3" Horizontal Flange	2" S.S. or Galv.
39-0017	4" Guide Rail System, Non-Sparking for Class 1 Group C and/or Group D Division 1 Installation	4" Horizontal Flange	2" S.S. or Galv.
39-0096	Intermediate bracket for 3" Rail Systems		
39-0014	Intermediate bracket for 4" Rail Systems (Stainless Steel)		

## FLYGT GUIDE RAIL SYSTEM ADAPTERS

Adapter plates for retrofitting 3" & 4" horizontal ANSI flange discharge pumps to existing Flygt rail systems.

Pump Discharge	Part Number
3"	6039-0070
4"	6039-0048

### DESIGN FEATURES:

Cast iron construction.

Flange conforms to ANSI B16.10 fully flat. MSS SP-6.

For use with all 400, 600 & 700 series pumps with 3" or 4" discharge and 2" rail pipe.

Flange gasket and stainless steel bolts included.

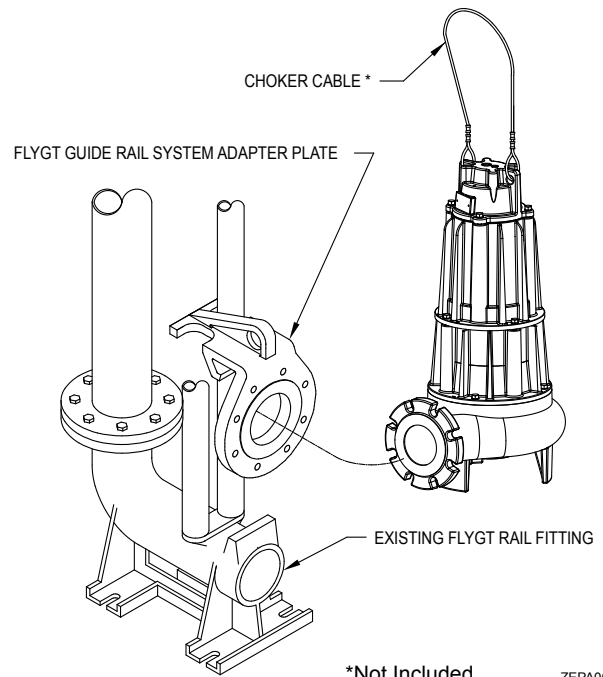

\*Not Included

ZEPA0601

**▲ CAUTION**

All installation of controls, protection devices and wiring should be done by a qualified licensed electrician. All electrical and safety codes should be followed including the most recent National Electrical Code (NEC) and the Occupational Safety and Health Act (OSHA).