



Product information presented here reflects conditions at time of publication. Consult factory regarding discrepancies or inconsistencies.

**PUMP COMPANY**

Zoeller Family of Water Solutions™

MAIL TO: P.O. BOX 16347 • Louisville, KY 40256-0347  
 SHIP TO: 3649 Cane Run Road • Louisville, KY 40211-1961  
 (502) 778-2731 • 1 (800) 928-PUMP • FAX (502) 774-3624

visit our web site:  
[www.zoeller.com](http://www.zoeller.com)

# INSTALLATION INSTRUCTIONS



## 2000 SERIES HIGH TEMPERATURE INTERMITTENT PUMPS AVAILABLE MODELS

SERIES	H.P.	DISCHARGE	SOLIDS	PH	MATERIAL
2057 Series	1/3	1 1/2"	1/2"	1	Cast Iron/Stainless Steel
2098 Series	1/2	1 1/2"	1/2"	1	Cast Iron/Stainless Steel
2137 Series	1/2	1 1/2"	5/8"	1	Cast Iron/Stainless Steel
2282 Series	1/2	2" or 3"	2"	1	Cast Iron/Stainless Steel

P/N 014028

## PREINSTALLATION CHECKLIST - ALL INSTALLATIONS

1. **Inspect your pump.** Occasionally, products are damaged during shipment. If the unit is damaged, contact your dealer before using. **DO NOT** remove the test plugs in the cover nor the motor housing.
2. **Carefully read the literature** provided to familiarize yourself with specific details regarding installation and use. These materials should be retained for future reference.

 <div style="border: 2px solid black; padding: 5px; display: inline-block;"> <p><b>WARNING</b></p> </div> <p>SEE BELOW FOR LIST OF WARNINGS</p> <ol style="list-style-type: none"> <li>1. <b>Make sure there is a properly grounded receptacle available.</b> All pumps are furnished with provisions for proper grounding to protect you against the possibility of electrical shock. (SEE WARNING BELOW)</li> <li>2. Make certain that the receptacle is within the reach of the pump's power supply cord. <b>DO NOT USE AN EXTENSION CORD.</b> Extension cords that are too long or too light do not deliver sufficient voltage to the pump motor. But, more important, they could present a safety hazard if the insulation were to become damaged or the connection end were to fall into the sump.</li> <li>3. <b>Make sure the pump electrical supply circuit is equipped with fuses or circuit breakers of proper capacity.</b> A separate branch circuit is recommended, sized according to the "National Electrical Code" for the current shown on the pump nameplate.</li> <li>4. <b>Testing for ground.</b> As a safety measure, each electrical outlet should be checked for ground using an Underwriters Laboratory Listed circuit analyzer which will indicate if the power, neutral and ground wires are correctly connected to your outlet. If they are not, call a qualified licensed electrician.</li> <li>5. <b>For Added Safety.</b> Pumping and other equipment with a 3-prong grounded plug must be connected to a 3-prong grounded receptacle. For added safety the receptacle may be protected with a ground-fault circuit interrupter. When a pump needs to be connected in a watertight junction box, the plug can be removed and spliced to the supply cable with proper grounding. For added safety this circuit may be protected by a ground-fault circuit interrupter. The complete installation must comply with the National Electrical Code and all applicable local codes and ordinances.</li> <li>6. <b>FOR YOUR PROTECTION, ALWAYS DISCONNECT PUMP FROM ITS POWER SOURCE BEFORE HANDLING.</b> Single phase pumps are supplied with a 3-prong grounded plug to help protect you against the possibility of electrical shock. <b>DO NOT UNDER ANY CIRCUMSTANCES REMOVE THE GROUND PIN.</b> The 3-prong plug <b>must</b> be inserted into a mating 3-prong grounded receptacle. If the installation does not have such a receptacle, it must be changed to the proper type, wired and grounded in accordance with the National Electrical Code and all applicable local codes and ordinances. Three phase pumps require motor starting devices with motor overload protection. See FM0514 for simplex installations or FM0486 for duplex installations. Pumps <b>must</b> be installed in accordance with the National Electrical Code and all applicable local codes and ordinances. Pumps are not to be installed in locations classified as hazardous in accordance with National Electrical Code, ANSI/NFPA 70.</li> <li>7. <b>"Risk of electrical shock"</b> Do not remove power supply cord and strain relief or connect conduit directly to the pump.</li> <li>8. Installation and servicing of electrical circuits and hardware should be performed by a qualified licensed electrician.</li> <li>9. Pump installation and servicing should be performed by a qualified person.</li> <li>10. Risk of electric shock - These pumps have not been investigated for use in swimming pool areas.</li> <li>11. According to the state of California (Prop 65), this product contains chemicals known to the state of California to cause cancer and birth defects or other reproductive harm.</li> </ol>	 <div style="border: 2px solid black; padding: 5px; display: inline-block;"> <p><b>CAUTION</b></p> </div> <p>SEE BELOW FOR LIST OF CAUTIONS</p> <ol style="list-style-type: none"> <li>1. Check to be certain your power source is capable of handling the voltage requirements of the motor, as indicated on the pump name plate.</li> <li>2. Check valves used in High Temperature service must be all <b>metal swing type</b> check valves.</li> <li>3. Dewatering and effluent sump pumps are not designed to handle raw sewage.</li> <li>4. Maximum intermittent operating temperature for high temperature pumps must not exceed 200°F - 93°C.</li> <li>5. The installation of automatic pumps with variable level float switches or nonautomatic pumps using auxiliary variable level float switches is the responsibility of the installing party and care should be taken that the tethered float switch will not hang up on the pump apparatus or pit peculiarities and is secured so that the pump will shut off. It is recommended to use rigid piping and fittings and the pit be 18" or larger in diameter.</li> <li>6. Information - vent hole purpose. It is necessary that all submersible sump, effluent, and sewage pumps capable of handling various sizes of solid waste be of the bottom intake design to reduce clogging and seal failures. If a check valve is incorporated in the installation, a vent hole (approx. 3/16") must be drilled in the discharge pipe below the check valve and pit cover to purge the unit of trapped air. Trapped air is caused by agitation and/or a dry basin. Vent hole should be checked periodically for clogging. The 50 or 90 Series pumps have a vent located in the pump housing opposite the float, adjacent to a housing lug, but an additional vent hole is recommended. The vent hole on some applications may cause too much turbulence. You may not want to drill one. If you choose not to drill a vent hole, be sure the pump case and impeller is covered with liquid before connecting the pipe to the check valve and no inlet carries air to the pump intake. <b>NOTE: THE HOLE MUST ALSO BE BELOW THE BASIN COVER AND CLEANED PERIODICALLY.</b> Water stream will be visible from this hole during pump run periods.</li> <li>7. Pump should be checked frequently for debris and/or build up which may interfere with the float "on" or "off" position. Repair and service should be performed by Zoeller Pump Company Authorized Service Station only.</li> <li>8. Do not operate a pump in an application where the Total Dynamic Head is less than the minimum Total Dynamic Head listed on the Pump Performance Curves.</li> </ol>
<p><b>REFER TO WARRANTY ON PAGE 2.</b></p>	

## LIMITED WARRANTY

Manufacturer warrants, to the purchaser and subsequent owner during the warranty period, every new product to be free from defects in material and workmanship under normal use and service, when properly used and maintained, for a period of one year from date of purchase by the end user, or 18 months from date of original manufacture of the product, whichever comes first. Parts that fail within the warranty period, one year from date of purchase by the end user, or 18 months from the date of original manufacture of the product, whichever comes first, that inspections determine to be defective in material or workmanship, will be repaired, replaced or remanufactured at Manufacturer's option, provided however, that by so doing we will not be obligated to replace an entire assembly, the entire mechanism or the complete unit. No allowance will be made for shipping charges, damages, labor or other charges that may occur due to product failure, repair or replacement.

This warranty does not apply to and there shall be no warranty for any material or product that has been disassembled without prior approval of Manufacturer, subjected to misuse, misapplication, neglect, alteration, accident or act of God; that has not been installed, operated or maintained in accordance with Manufacturer's installation instructions; that has been exposed to outside substances including but not limited to the following: sand, gravel, cement, mud, tar, hydrocarbons, hydrocarbon derivatives (oil, gasoline, solvents, etc.), or other abrasive or corrosive substances, wash towels or feminine sanitary products,

etc. in all pumping applications. The warranty set out in the paragraph above is in lieu of all other warranties expressed or implied; and we do not authorize any representative or other person to assume for us any other liability in connection with our products.

Contact Manufacturer at, 3649 Cane Run Road, Louisville, Kentucky 40211, Attention: Customer Service Department to obtain any needed repair or replacement of part(s) or additional information pertaining to our warranty.

**MANUFACTURER EXPRESSLY DISCLAIMS LIABILITY FOR SPECIAL, CONSEQUENTIAL OR INCIDENTAL DAMAGES OR BREACH OF EXPRESSED OR IMPLIED WARRANTY; AND ANY IMPLIED WARRANTY OF FITNESS FOR A PARTICULAR PURPOSE AND OF MERCHANTABILITY SHALL BE LIMITED TO THE DURATION OF THE EXPRESSED WARRANTY.**

Some states do not allow limitations on the duration of an implied warranty, so the above limitation may not apply to you. Some states do not allow the exclusion or limitation of incidental or consequential damages, so the above limitation or exclusion may not apply to you.

This warranty gives you specific legal rights and you may also have other rights which vary from state to state.

## PERFORMANCE CHARACTERISTICS

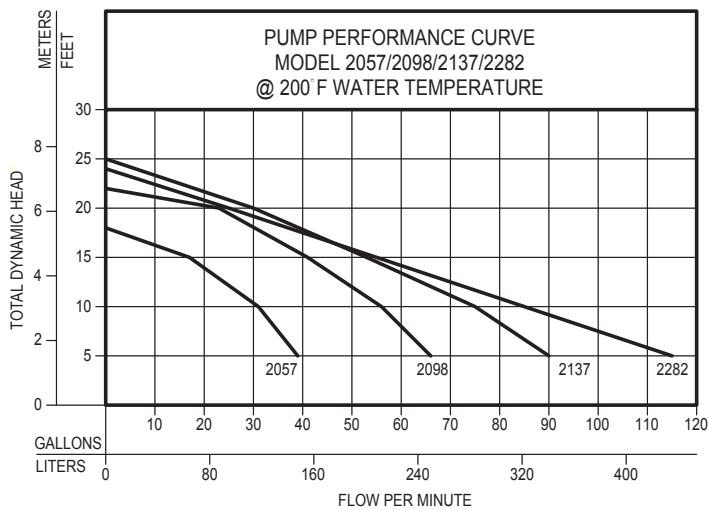

TOTAL DYNAMIC HEAD/FLOW  
PER MINUTE  
EFFLUENT AND DEWATERING

MODEL		2057		2098		2137		2282	
Feet	Meters	Gal.	Liters	Gal.	Liters	Gal.	Liters	Gal.	Liters
5	1.5	39	148	66	250	90	341	115	435
10	3.0	31	117	56	212	75	284	85	322
15	4.6	17	64	41	155	53	201	55	208
20	6.1	--	--	23	87	30	114	25	95
Shut-off Head:		18 ft.(5.5m)		22 ft.(6.7m)		25 ft.(7.6m)		24 ft.(7.3m)	

014036

## SWITCH DATA

**ENVIRONMENTAL LIMITATIONS:**

- Switch is designed for 200°F water or lower.
- Switch can be exposed to chemicals associated with boiler water treatment and at concentrations typically associated with this process.
- Not to be used with flammable liquids.
- Not meant for use in hazardous locations as defined by the National Electric Code and ANSI/NFPA 70.
- Switch is not designed to be directly wired to power source

## STEP 1

## INSTALLATION OF THE PUMP IN THE PIT (typical installation)

- 1.1) Refer to Figure 1.1 for a typical pump installation.

Figure 1.1

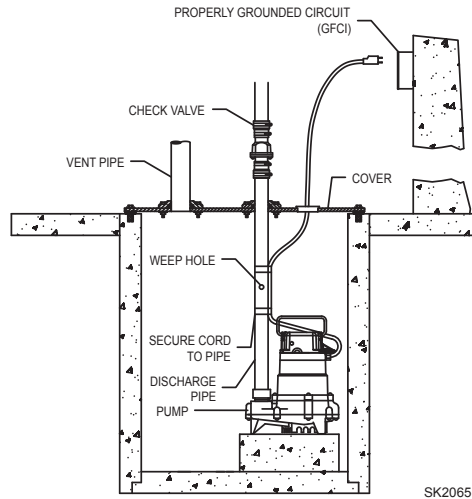

## STEP 2

## INSTALLATION OF THE VARIABLE LEVEL FLOAT SWITCH

- 2.1) Install the float attachment clamp as shown in Detail A. **IMPORTANT! DO NOT INSTALL SWITCH CORD UNDER HOSE CLAMP**
- 2.2) Set the pumping range according to Chart A and Figure 2.2.
- 2.3) Secure the hose clamp to the discharge pipe.

CHART A

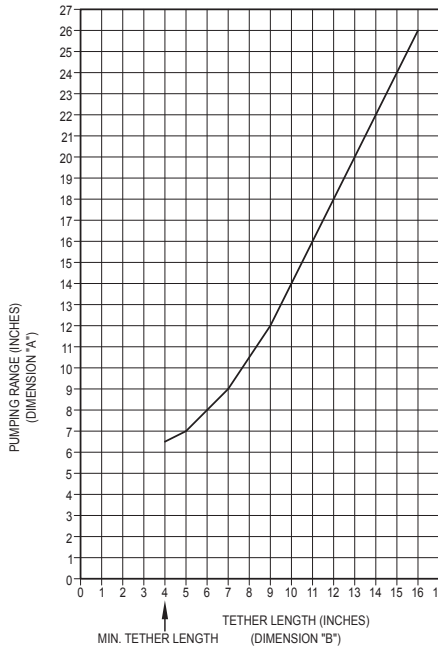

SK2175

DETAIL A

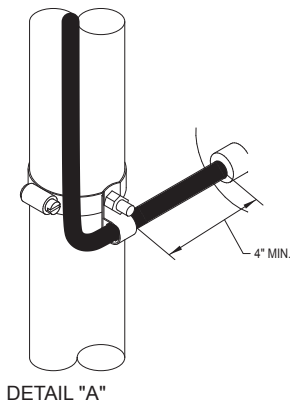

SK2067A

Figure 2.2

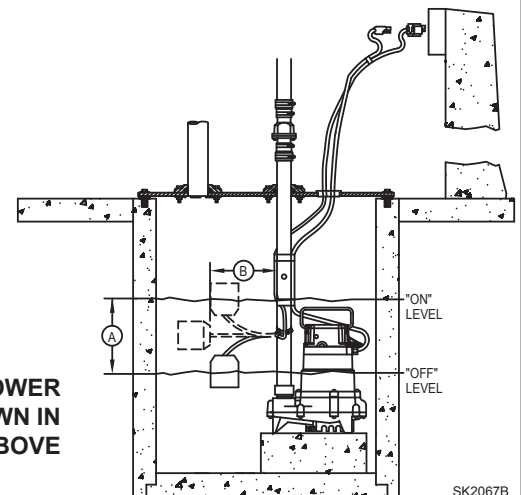

SK2067B

**IMPORTANT!** TETHER LENGTH CANNOT BE LESS THAN 4"

**IMPORTANT!** \*\*SECURE THE PUMP POWER CORD TO THE DISCHARGE PIPE AS SHOWN IN FIGURE 2.2. CORD SHOULD BE AT OR ABOVE THE PUMP "ON" LEVEL

### STEP 3

### VISUAL INSPECTION OF COMPLETE SYSTEM

- 3.1) With the pit cover removed and the pump unplugged, fill the pit with water.
- 3.2) As the pit is filling, verify that the float travel is not obstructed by the wall or any other object.
- 3.3) If the float is obstructed, remove obstruction and or adjust the tether length per STEP 2.

### STEP 4

### OPERATIONAL TEST OF COMPLETE SYSTEM

- 4.1) With the cover removed, temporarily connect the discharge pipe.  
**NOTE: At this point the pit is filled with water and the float is in the "on" position.**
- 4.2) Plug the float switch into the outlet and the pump plug into the float plug. (Refer to Figure 4.2) The pump should immediately empty the pit, if the pump does not turn "on" continue filling the pit with water.  
**NOTE: If the pump does not turn "on/off", and the float is in the vertical position and/or submerged, refer to the troubleshooting guide at the end of this manual.**
- 4.3) Verify that the pump cycles on and that the desired "pump-down" range is acceptable.
- 4.4) Repeat manual cycling of pump as necessary to insure proper operation.
- 4.5) Unplug the pump, disconnect the discharge pipe, replace cover and complete the installation as shown in Figure 4.2.

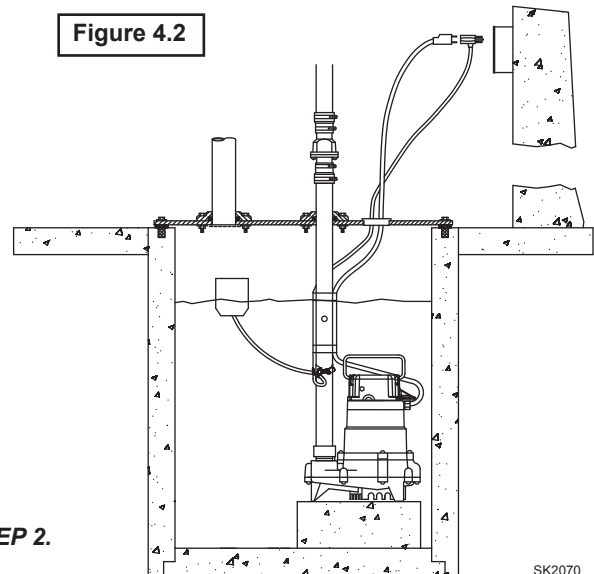

**NOTE: If too little water is removed, adjust the tether length per STEP 2.**

**IMPORTANT!** Repeat Step 3 & 4 if tether length is adjusted.

### TROUBLE SHOOTING GUIDE



**WARNING** ELECTRICAL PRECAUTIONS- Before servicing a pump, always shut off the main power breaker and then unplug the pump - making sure you are not standing in water and are wearing insulated protective sole shoes. Under flooded conditions, contact your local electric company or a qualified licensed electrician for disconnecting electrical service prior to pump removal.

**CAUTION** Submersible pumps contain oils which becomes pressurized and hot under operating conditions - allow 2½ hours after disconnecting before attempting service.

CONDITION	COMMON CAUSES
A. Pump will not start or run.	Check fuse, low voltage, overload open, open or incorrect wiring, open switch, impeller or seal bound mechanically, defective capacitor or relay when used, motor or wiring shorted. Float assembly held down. Switch defective, damaged, or out of adjustment.
B. Motor overheats and trips overload or blows fuse.	Incorrect voltage, negative head (discharge open lower than normal) impeller or seal bound mechanically, defective capacitor or relay, motor shorted.
C. Pump starts and stops too often.	Check valve stuck or none installed in long discharge line, overload open, level switch(s) defective, sump pit too small.
D. Pump will not shut off.	Debris under float assembly, float bound by pit sides or other obstruction, switch defective, damaged or out of adjustment.
E. Pump operates but delivers little or no water.	Check strainer housing, discharge pipe, or if check valve is used vent hole must be open. Discharge head exceeds pump capacity. Low or incorrect voltage. Incorrect motor rotation. Capacitor defective. Incoming water containing air or causing air to enter pump.
F. Drop in head and/or capacity after a period of use.	Increased pipe friction, clogged line or check valve. Abrasive material and adverse chemicals could possibly deteriorate impeller and pump housing. Check line. Remove base and inspect.

If the above check list does not uncover the problem, consult the factory - Do not attempt to service or otherwise disassemble pump. Service must be by Zoeller Authorized Service Stations.