

Notice to Installer: Instructions must remain with installation.

Your Peace of Mind is Our Top Priority®



SECTION: 6.10.024

FM2671

0312

Supersedes

1211

Product information presented here reflects conditions at time of publication. Consult factory regarding discrepancies or inconsistencies.

PUMP COMPANY

Zoeller Family of Water Solutions™

MAIL TO: P.O. BOX 16347 • Louisville, KY 40256-0347
SHIP TO: 3649 Cane Run Road • Louisville, KY 40211-1961
(502) 778-2731 • 1 (800) 928-PUMP • FAX (502) 774-3624

visit our web site:
www.zoeller.com

| | |
|-----------------|-------|
| MODEL: | _____ |
| DATE CODE: | _____ |
| DATE INSTALLED: | _____ |

915 GRINDER PACKAGE (Preassembled)



INSTALLATION INSTRUCTIONS PREINSTALLATION CHECKLIST

1. Inspect your unit. Occasionally, products are damaged during shipment. If the unit is damaged, contact your dealer before using. **DO NOT** remove the test plugs from the pump.
2. Carefully read the literature provided to familiarize yourself with specific details regarding installation and use. These materials should be retained for future reference.



WARNING

SEE BELOW FOR LIST OF WARNINGS

CAUTION

SEE BELOW FOR LIST OF CAUTIONS

1. To reduce the risk of electrical shock, a properly grounded receptacle of grounding type must be installed and protected by a ground fault circuit interrupter (GFCI) and in accordance with National Electrical Code and local codes. **(SEE WARNING BELOW).**
 2. Make certain that the receptacle is within the reach of the pump's power supply cord. **DO NOT USE AN EXTENSION CORD.** Extension cords that are too long or too light do not deliver sufficient voltage to the pump motor. But more important, they could present a safety hazard if the insulation were to become damaged or the connection end were to fall into the sump.
 3. Testing for Ground. As a safety measure, each electrical outlet should be checked for ground using an Underwriters Laboratory Listed circuit analyzer which will indicate if the power, neutral and ground wires are correctly connected to your outlet. If they are not, call a qualified electrician.
 4. For Added Safety. Pump must be connected to a 3-prong grounded outlet interrupter device (ground fault circuit interrupter).
 5. **FOR YOUR PROTECTION, ALWAYS DISCONNECT PUMP FROM ITS POWER SOURCE BEFORE HANDLING.** Single phase pumps are supplied with a 3-prong grounded plug to help protect you against the possibility of electrical shock. **DO NOT, UNDER ANY CIRCUMSTANCES, REMOVE THE GROUND PIN.** To reduce the risk of electrical shock, a properly grounded receptacle of grounding type must be installed and protected by a ground fault circuit interrupter (GFCI) in accordance with national electrical code and local codes.
 6. Installation and checking of electrical circuits and hardware should only be performed by a qualified licensed electrician.
 7. Risk of electric shock - These pumps have not been investigated for use in swimming pool areas.
 8. According to the state of California (Prop 65), this product contains chemicals known to the state of California to cause cancer and birth defects or other reproductive harm.
1. Check to be sure your power source is adequate for handling the voltage requirements of the motor, as indicated on the pump or basin plate.
 2. Make sure the pump electrical supply circuit is equipped with fuses or circuit breakers of proper capacity. A separate branch circuit is recommended, sized according to the National Electrical Code for the current shown on the pump name plate.
 3. All plumbing (discharge and vent lines) must be installed to meet local codes. Unit must be vented. Some states require this unit to be installed by a qualified licensed plumber. **DO NOT USE AN AUTOMATIC PLUMBING VENT DEVICE SIMILAR TO A "PRO-VENT".**
 4. Repair and service should be performed by Zoeller Pump Company Authorized Service Station only.
 5. **CHECK VALVE MUST BE USED TO REDUCE UNNECESSARY CYCLING OF PUMP.**
 6. Dewatering pumps are not designed or intended for handling raw sewage.
 7. Maximum operating temperature for 915 Grinder Pumps must not exceed 110°F (43°C).
 8. For health reasons, do not unplug, turn off, or disable pump and use pump tank system as a way to fill up a sink or laundry tray, etc.
- NOTE: Pumps with the "UL" mark and pumps with the "US" mark are tested to UL Standard UL778. CSA Certified pumps are certified to CSA Standard C22.2 No. 108.
- REFER TO WARRANTY ON PAGE 2.**

Limited Warranty

Manufacturer warrants, to the purchaser and subsequent owner during the warranty period, every new product to be free from defects in material and workmanship under normal use and service, when properly used and maintained, for a period of one year from date of purchase by the end user, or 18 months from date of original manufacture of the product, whichever comes first. Parts that fail within the warranty period, one year from date of purchase by the end user, or 18 months from the date of original manufacture of the product, whichever comes first, that inspections determine to be defective in material or workmanship, will be repaired, replaced or remanufactured at Manufacturer's option, provided however, that by so doing we will not be obligated to replace an entire assembly, the entire mechanism or the complete unit. No allowance will be made for shipping charges, damages, labor or other charges that may occur due to product failure, repair or replacement.

This warranty does not apply to and there shall be no warranty for any material or product that has been disassembled without prior approval of Manufacturer, subjected to misuse, misapplication, neglect, alteration, accident or act of God; that has not been installed, operated or maintained in accordance with Manufacturer's installation instructions; that has been exposed to outside substances including but not limited to the following: sand, gravel, cement, mud, tar, hydrocarbons, hydrocarbon derivatives (oil, gasoline, solvents, etc.), or other abrasive or corrosive substances, wash towels or feminine sanitary products, etc. in all pumping applications. The warranty set

out in the paragraph above is in lieu of all other warranties expressed or implied; and we do not authorize any representative or other person to assume for us any other liability in connection with our products.

Contact Manufacturer at, 3649 Cane Run Road, Louisville, Kentucky 40211, Attention: Product Support Department to obtain any needed repair or replacement of part(s) or additional information pertaining to our warranty.

MANUFACTURER EXPRESSLY DISCLAIMS LIABILITY FOR SPECIAL, CONSEQUENTIAL OR INCIDENTAL DAMAGES OR BREACH OF EXPRESSED OR IMPLIED WARRANTY; AND ANY IMPLIED WARRANTY OF FITNESS FOR A PARTICULAR PURPOSE AND OF MERCHANTABILITY SHALL BE LIMITED TO THE DURATION OF THE EXPRESSED WARRANTY.

Some states do not allow limitations on the duration of an implied warranty, so the above limitation may not apply to you. Some states do not allow the exclusion or limitation of incidental or consequential damages, so the above limitation or exclusion may not apply to you.

This warranty gives you specific legal rights and you may also have other rights which vary from state to state.

Service Checklist



▲ WARNING ELECTRICAL PRECAUTIONS- Before servicing a pump, always shut off the main power breaker and then unplug the pump - making sure you are not standing in water and wearing insulated protective sole shoes. Under flooded conditions, contact your local electric company or a qualified licensed electrician for disconnecting electrical service prior to pump removal.

▲ WARNING Submersible pumps can become pressurized under normal operating conditions — allow 2½ hours after disconnecting before attempting service.

| CONDITION | COMMON CAUSES |
|--|---|
| A. Pump will not start or run. | Check fuse, low voltage, overload open, open or incorrect wiring, open switch, impeller or seal bound mechanically, defective capacitor or relay when used, motor or wiring shorted. Float assembly held down. Switch defective, damaged, or out of adjustment. |
| B. Motor overheats and trips overload or blows fuse. | Incorrect voltage, negative head (discharge open lower than normal) impeller or seal bound mechanically, defective capacitor or relay, motor shorted. |
| C. Pump starts and stops too often. | Float switch tether length too short, check valve stuck, or none installed in long distance line, overload open, switch defective. |
| D. Pump will not shut off. | Debris under float assembly, float bound by basin sides or other, switch defective, damaged or out of adjustment. |
| E. Pump operates but delivers little or no water. | Check pump inlet, discharge pipe, and weep holes for obstructions. System head exceeds pump capacity. Low or incorrect voltage. Capacitor defective. Incoming water containing air or causing air to enter pumping chamber. |
| F. Drop in head and/or capacity after a period of use. | Increased pipe friction, clogged line or check valve. Abrasive material and adverse chemicals could possibly deteriorate impeller and pump housing. Check line. Inspect pump inlet. |
| G. If tank or fittings leak. | Carefully tighten pipe joints (use pipe dope) and screws. Check gasket location, tighten lid evenly. Do not over tighten fittings or screws. |

If the above checklist does not uncover the problem, consult the Product Support Department; do not attempt to service or otherwise disassemble pump. Service must be by Zoeller Authorized Service Stations.

Helpful Hints For Easy Installation

- | | |
|--|---|
| <ol style="list-style-type: none"> 1. Read all instructions before beginning installation. 2. Be certain that basin is on a firm level surface. 3. Do not use an automatic plumbing vent device. 4. Always install the check valve on the discharge line. 5. Always provide some means, such as a union, to disconnect the pump assembly from the basin for maintenance purposes. | <ol style="list-style-type: none"> 6. Run unit at least once a month to verify proper operation. 7. The model number and date code can be found on the lid warning label. 8. Plug pump into a properly grounded GFCI receptacle. |
|--|---|

Do's And Don't's For Installing A Unit

- | | |
|---|---|
| <ol style="list-style-type: none"> 1. DO read all installation material included with the pump. 2. DO inspect unit for any visible damage caused by shipping. Contact dealer if unit appears to be damaged. 3. DO always disconnect pump from power source before handling. DO always connect to a separately protected and properly grounded ground fault protected circuit. DO NOT ever cut, splice or damage power cord. DO NOT carry or lift pump by its power cord. DO NOT use an extension cord. | <ol style="list-style-type: none"> 4. DO NOT use a discharge pipe smaller than the pump discharge size. 5. DO test pump immediately after installation to be sure that the system is working properly. 6. DO review all applicable local and national codes and verify that the installation conforms to each of them. |
|---|---|

915 Grinder Features

Tri-Slice™ cutter technology - three independent cutting channels provide over 250,000 cuts/minute.

IBAD™ - Integral Baffling and Deflection System allows solids up to 4" to enter the basin without becoming lodged; minimizes potential float obstruction.

Basin Scouring System™ automatically agitates standing liquid to prevent grease and sludge build up. Engineered for the life of the system; no moving parts to wear out.

Performance Characteristics

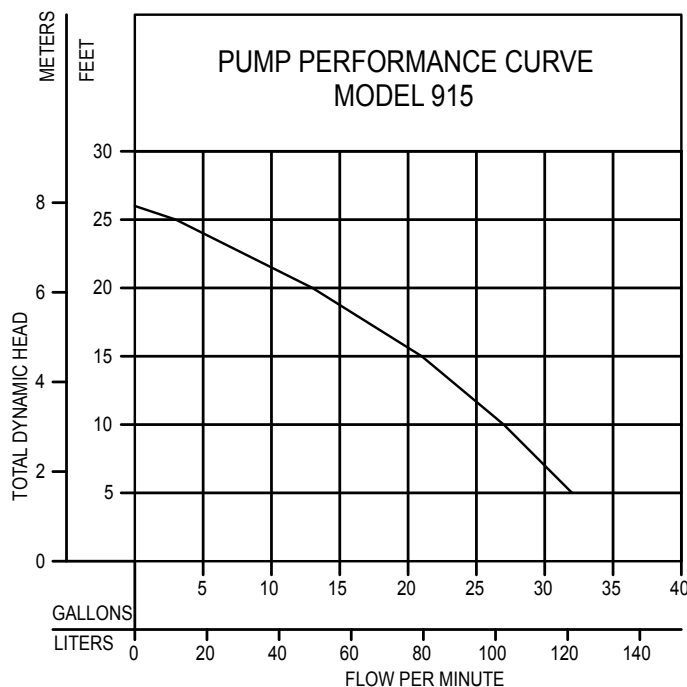

TOTAL DYNAMIC HEAD/FLOW PER MINUTE SEWAGE

| MODEL | | 915 | |
|----------------|--------|---------------|--------|
| Feet | Meters | Gal. | Liters |
| 5 | 1.5 | 32 | 121 |
| 10 | 3.0 | 27 | 102 |
| 15 | 4.6 | 21 | 79 |
| 20 | 6.1 | 13 | 49 |
| 25 | 7.6 | 3 | 11 |
| Shut-off Head: | | 26 ft. (7.9m) | |

151790

Final Assembly

NOTE: External plumbing configuration will vary depending on the location of basin, location of main stack and available space.

Place the basin assembly in its final position and complete plumbing. Secure all connections shown in Figure 1.

Attach check valve to the discharge pipe above cover.

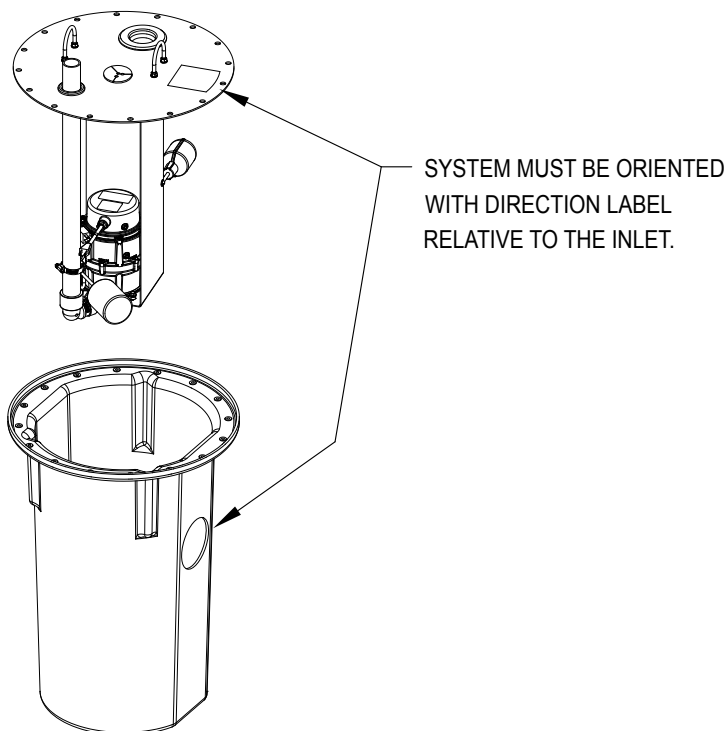
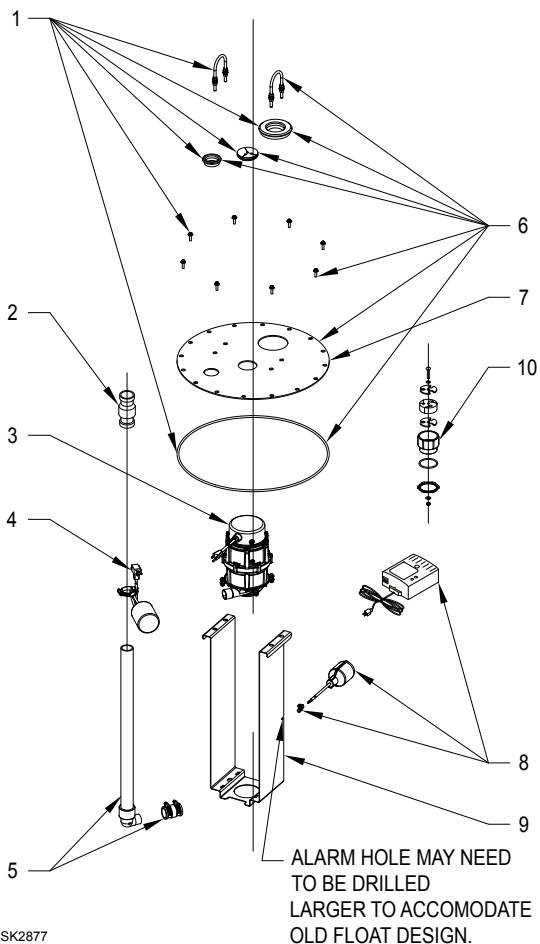

Figure 1

SK2896

Illustrated Parts Breakdown



SK2877

| | | MODEL : | | |
|------|--|---------|-----------------------|--------------------------|
| | | 915-A | 915-B | |
| ITEM | DESCRIPTION | QTY | 8/11 thru 11/11 | 12/11 thru Current |
| 1 | HARDWARE KIT - STD/10'STACK | 1 | 151846 | 151939 |
| 2 | CHECK VALVE - SHIPPED LOOSE FOR FIELD INSTALLATION | 1 | 30-0237 | 30-0239 |
| 3 | 801 PUMP | 1 | 151692 | 151692 |
| 4 | PIGGYBACK FLOAT | 1 | 151847 | 151847 |
| 5 | PIPE ASSEMBLY | 1 | 151848 | 151940 |
| 6 | BASIN COVER AND HARDWARE KIT - STD | 1 | 151849 | 151941 |
| | BASIN COVER AND HARDWARE KIT - 10' STACK | | N/A | 151951 |
| 7 | BASIN COVER - STD | 1 | 17-0804 | 17-0828 |
| | BASIN COVER - 10' STACK | | N/A | 17-0830 |
| 8 | ALARM | 1 | 151850 | 151850 |
| 9 | BRACKET - 24" DEEP BASIN | 1 | 151760 | 151760 |
| | BRACKET - 30" DEEP BASIN | | 150849 | 150849 |
| 10 | 10' CORD SEAL ASM | 1 | 151891 | 151891 |