

# Engineering Specification

Job Name \_\_\_\_\_  
 Job Location \_\_\_\_\_  
 Engineer \_\_\_\_\_  
 Approval \_\_\_\_\_  
 Tag \_\_\_\_\_

Contractor \_\_\_\_\_  
 Approval \_\_\_\_\_  
 Contractor's P.O. No. \_\_\_\_\_  
 Representative \_\_\_\_\_

## QT-132 QT QuickTurn™ 1000 lb. Single Vertical Adjustable Closet Carrier with Side Inlet(s) Specification

Pat. No. 10,895,070

Watts QT-132 single vertical adjustable water closet carrier with epoxy coated cast iron fitting, 4"(102) no hub waste and 2"(51) no hub vent connections, 4"(102) no hub side inlet(s), epoxy coated cast iron patented faceplate assembly, epoxy coated cast iron foot supports with incremental height markings, and rear anchor bar. Adjustable for standard and wheelchair height, adjustable ABS nipple with integral test cap and neoprene bowl gasket, plated hardware and chrome cap nuts. Carrier complies with the requirements of ASME A112.6.1M up to a 1000 lb. (454 kg) static load.

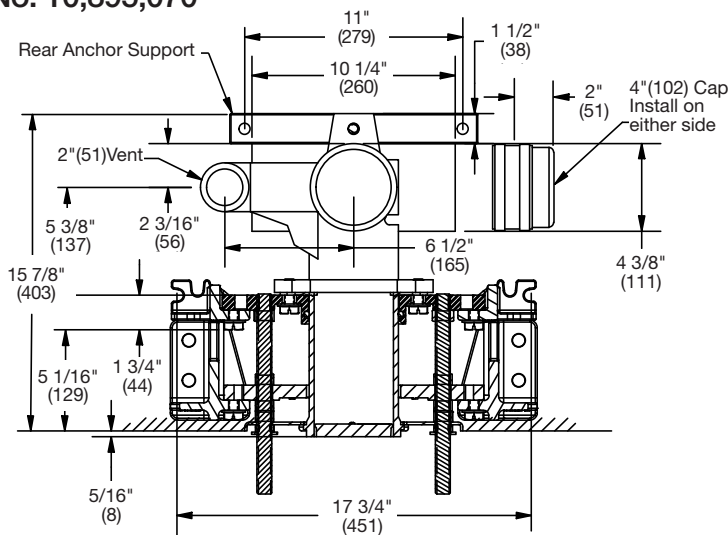

Suffix	Options Description	
-HS	Hub & Spigot Connections	<input type="checkbox"/>

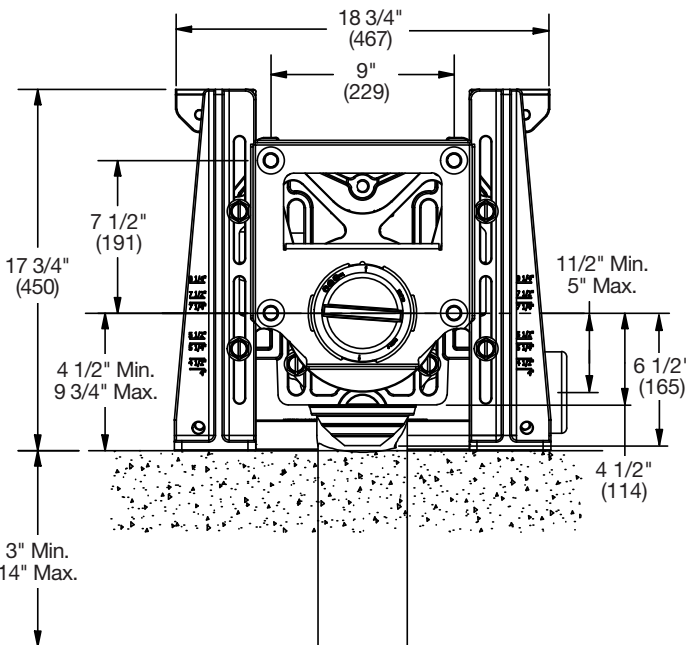

**NOTICE**

Anchor legs and rear anchor bar to concrete floor with minimum 1/2"(13) anchor bolts (by others).

Front carrier feet with holes require two 1/2"(13) anchor bolts per foot. Rear slotted carrier feet require minimum one 1/2"(13) anchor bolt per foot.

**NOTICE**

The information contained herein is not intended to replace the full product installation and safety information available or the experience of a trained product installer. You are required to thoroughly read all installation instructions and product safety information before beginning the installation of this product.

Watts product specifications in U.S. customary units and metric are approximate and are provided for reference only. For precise measurements, please contact Watts Technical Service. Watts reserves the right to change or modify product design, construction, specifications, or materials without prior notice and without incurring any obligation to make such changes and modifications on Watts products previously or subsequently sold.



USA: T: (800) 338-2581 • F: (828) 248-3929 • Watts.com  
 Canada: T: (888) 208-8927 • F: (888) 479-2887 • Watts.ca  
 Latin America: T: (52) 55-4122-0138 • Watts.com