

Engineering Specification

Job Name _____ Contractor _____

Job Location _____ Approval _____

Engineer _____ Contractor's P.O. No. _____

Approval _____ Representative _____

Tag _____

QT-103-L/R QT QuickTurn™ 750 lb. Single Horizontal Adjustable Closet Carrier Specification

Pat. No. 10,895,070

Watts QT-103-L/R single horizontal adjustable closet carrier with epoxy coated cast iron fitting, 4"(102) no hub waste and 2"(51) no hub vent connections, epoxy coated cast iron patented faceplate assembly, epoxy coated cast iron foot supports with incremental height markings, and rear anchor bar. Adjustable for standard and wheelchair height, adjustable ABS nipple with integral test cap and neoprene bowl gasket, stainless steel support rods and chrome cap nuts. Carrier complies with the requirements of ASME A112.6.1M up to a 750 lb. (340 kg) static load.

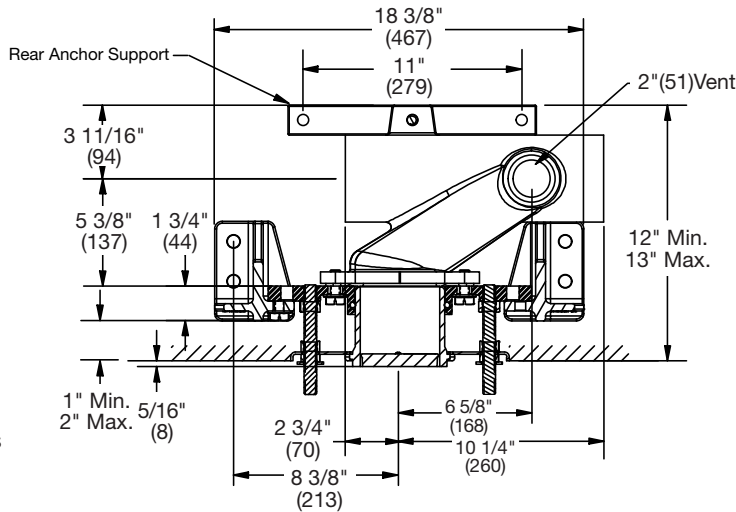

Suffix	Options Description	
-3	3" No Hub Fitting	<input type="checkbox"/>
-36	36" Long Barrel Fitting	<input type="checkbox"/>
-HS	Hub & Spigot Connections	<input type="checkbox"/>

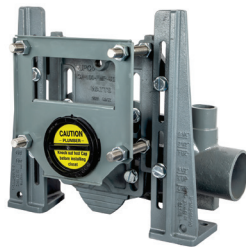

QT-103-L Shown

NOTICE

Anchor legs and rear anchor bar to concrete floor with minimum 1/2"(13) anchor bolts (by others).

Carrier feet require two 1/2"(13) anchor bolts per foot.

NOTICE

The information contained herein is not intended to replace the full product installation and safety information available or the experience of a trained product installer. You are required to thoroughly read all installation instructions and product safety information before beginning the installation of this product.

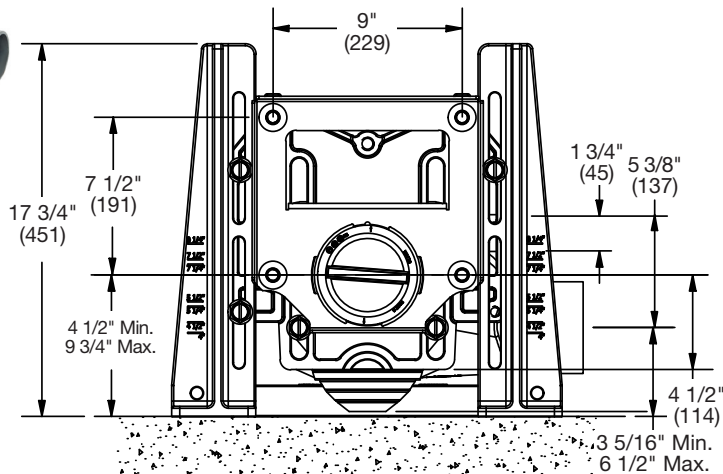

Watts product specifications in U.S. customary units and metric are approximate and are provided for reference only. For precise measurements, please contact Watts Technical Service. Watts reserves the right to change or modify product design, construction, specifications, or materials without prior notice and without incurring any obligation to make such changes and modifications on Watts products previously or subsequently sold.



USA: T: (800) 338-2581 • F: (828) 248-3929 • Watts.com
 Canada: T: (888) 208-8927 • F: (888) 479-2887 • Watts.ca
 Latin America: T: (52) 55-4122-0138 • Watts.com