

Engineering Specification

Job Name _____
 Job Location _____
 Engineer _____
 Approval _____
 Tag _____

Contractor _____
 Approval _____
 Contractor's P.O. No. _____
 Representative _____

QT-102-D QT QuickTurn™ 1000 lb. Back-To-Back Horizontal Adjustable Closet Carrier

Pat. No. 10,895,070

Specification

Watts QT-102-D back-to-back horizontal adjustable closet carrier with epoxy coated cast iron fitting, 4"(102) no hub waste and 2"(51) no hub vent connections, epoxy coated cast iron patented faceplate assembly, and epoxy coated cast iron foot supports with incremental height markings. Adjustable for standard and wheelchair height, adjustable ABS nipple with integral test cap and neoprene bowl gasket, stainless steel support rods and chrome cap nuts. Carrier complies with the requirements of ASME A112.6.1M up to a 1000 lb. (454 kg) static load.

Suffix	Options Description	
-3	3" No Hub Fitting	<input type="checkbox"/>
-36	36" Long Barrel Fitting	<input type="checkbox"/>
-HS	Hub & Spigot Connections	<input type="checkbox"/>



NOTICE

Anchor legs to concrete floor with minimum 1/2"(13) anchor bolts (by others).

Front carrier feet with holes require two 1/2"(13) anchor bolts per foot. Rear slotted carrier feet require minimum one 1/2"(13) bolt per foot.

NOTICE

The information contained herein is not intended to replace the full product installation and safety information available or the experience of a trained product installer. You are required to thoroughly read all installation instructions and product safety information before beginning the installation of this product.

Watts product specifications in U.S. customary units and metric are approximate and are provided for reference only. For precise measurements, please contact Watts Technical Service. Watts reserves the right to change or modify product design, construction, specifications, or materials without prior notice and without incurring any obligation to make such changes and modifications on Watts products previously or subsequently sold.

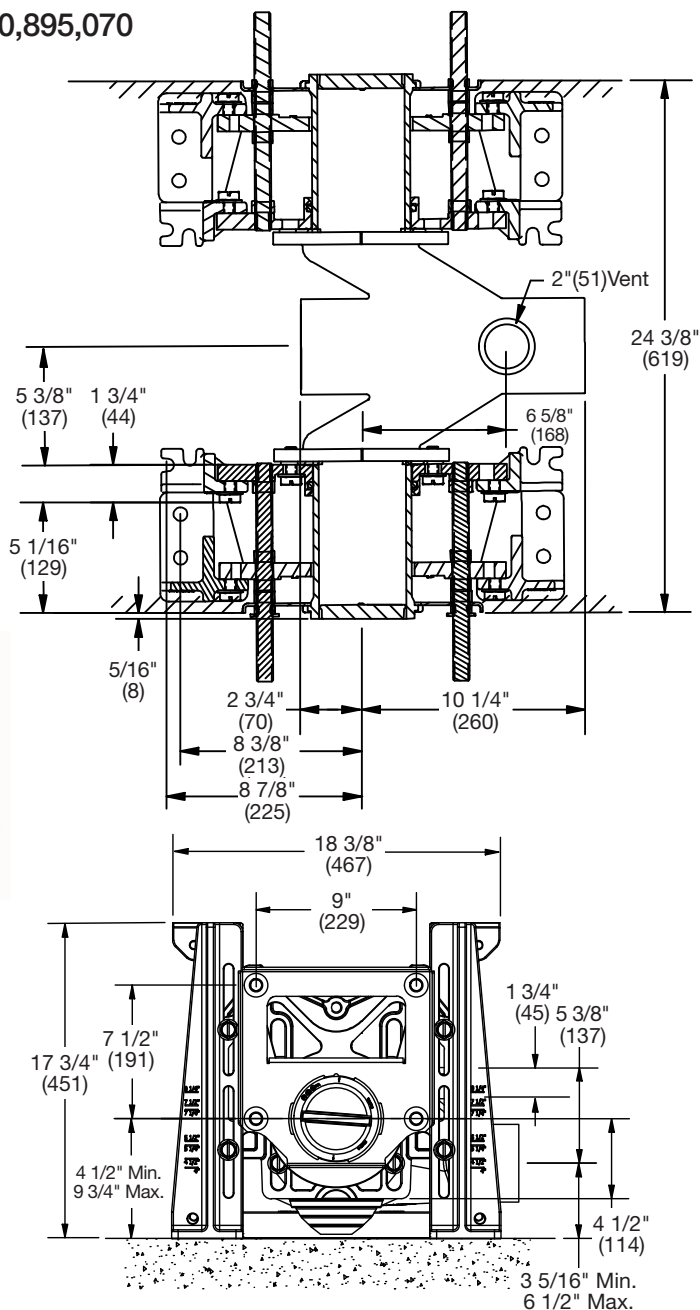

USA: T: (800) 338-2581 • F: (828) 248-3929 • Watts.com
Canada: T: (888) 208-8927 • F: (888) 479-2887 • Watts.ca
Latin America: T: (52) 55-4122-0138 • Watts.com