

Metal Tri-spoke Handle
STYLE No. RDVC40
CODE No. RDSV40

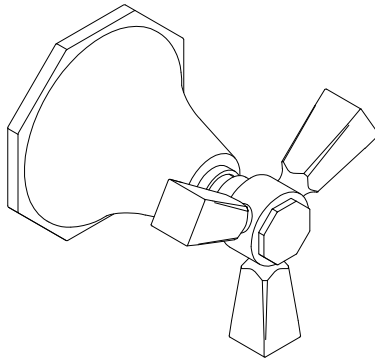

Metal Lever Handle
STYLE No. RDVC50
CODE No. RDSV50

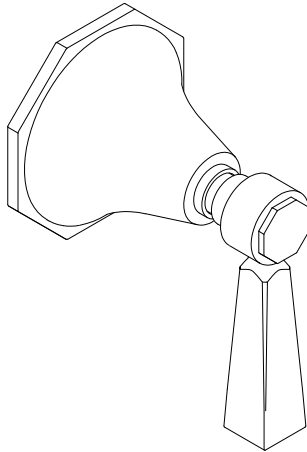

SPECIFICATIONS:

Volume Control Valve Rough-in Depth:
GUVC18R (GUSV18R) or GUVC19R (GUSV19R):
3/4" MIN - 4 1/4" MAX
2-Way Diverter with Shutoff Valve Rough-in Depth:
GUDV14R (GUSV14R): 3/4" MIN - 4 1/4" MAX
2-Way Diverter without Shutoff Valve Rough-in Depth:
GUDV23R (GUSV23R): 2 5/8" MIN - 3 5/8" MAX

REQUIRED PLUMBING DETAILS:

Universal 1/2" Volume Control Valve (Clockwise Close)
STYLE No. GUVC18R
CODE No. GUSV18R or,
Universal 1/2" Volume Control Valve (Counter-Clockwise Close)
STYLE No. GUVC19R
CODE No. GUSV19R or,
Universal 2-Way Diverter with Shutoff Valve
STYLE No. GUDV14R
CODE No. GUSV14R or,
Universal 2-Way Diverter without Shutoff Valve
STYLE No. GUDV23R
CODE No. GUSV23R

IMPORTANT:

- To ensure this product is installed properly, you must read and follow these guidelines.
- The owner/user of this product must keep this information for future reference.

- Anti-scald protection is the responsibility of the installer and according to applicable codes
- Be sure your installation conforms to all federal, state, and local codes. In the State of Massachusetts, all installations must comply with the rules and regulations set forth within 248 CMR.
- Wall valves control on/off/volume and must be installed for each fitting that will have water flowing to it. If using a wall valve with the Universal 1/2" Thermostatic Valve (**STYLE No.** GUTH56R), refer to the Installation Guidelines for the Thermostatic Valve which contains related installation information.
- This product must be installed by a professional licensed contractor and must be on-site prior to rough-in. This allows the installer to visualize the installation.
- Refer to the specification and assembly drawings attached. Product is sold partially assembled but shown fully disassembled for illustrative and service purposes only.
- Inspect this product to ensure you have all parts required for proper installation.
- Use only a strap wrench or protected/smooth-jaw wrench on any finished surface.

TRIM INSTALLATION WITH CONTROL VALVE:

1. Remove the tile guard and make a mark on the tube that is a 1/2" from the surface of the finished wall.
2. Remove then cut the tube at the mark made in Step 1. DO NOT cut the end of the tube with the internal threads. See Figure - 01.

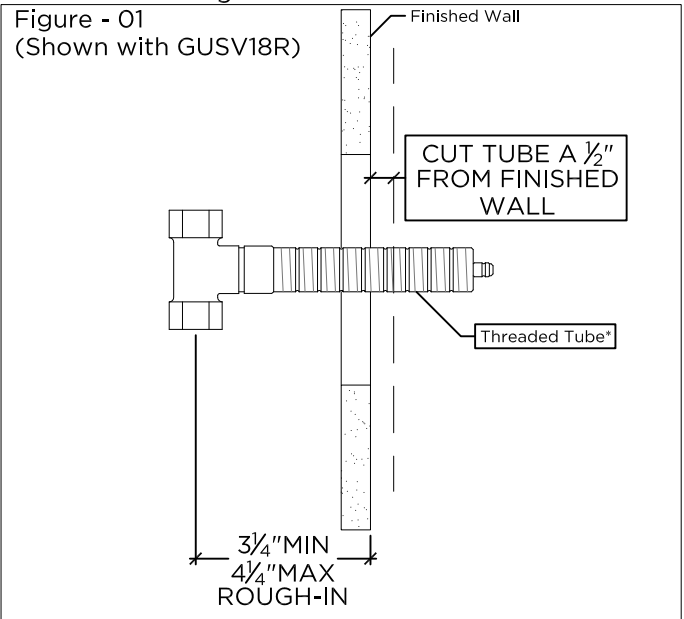

These guidelines have been prepared for the professional contractor to aid in the installation of:
ROADSTER VOLUME CONTROL VALVE TRIM METAL CROSS HANDLE (STYLE No. RDVC40) AND METAL LEVER HANDLES (STYLE No. RDVC50).
All dimensions are based on origin specification and are subject to change and variation. Please consult your Design Associate for current specifications.

**WATERWORKS
STUDIO**

3. Mark then cut the cartridge stem $1\frac{3}{8}$ " from the surface of the finished wall. See Figure - 02.

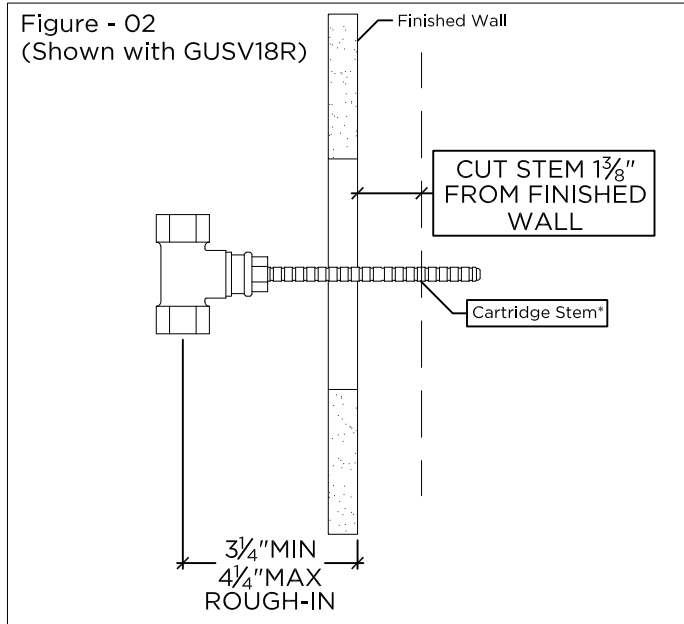

4. Re-install the threaded tube onto the valve.
5. Hold the escutcheon (8) to the finished wall then thread the gland cover (7) onto the threaded tube to hold the escutcheon against the finished wall. Make sure the washer (9) is behind the escutcheon.
6. Remove the indice (2) and screw (4) from the handle (1 or 5) then place the handle over the cartridge stem in the desired orientation.
7. Thread the screw into the cartridge stem to fix the handle then re-install the indice.

TRIM INSTALLATION WITH DIVERTER VALVE:

8. Remove the tile guard and make a mark on the tube that is $\frac{5}{8}$ " from the surface of the finished wall.
9. Remove then cut the tube at the mark made in Step 8. DO NOT cut the end of the tube with the internal threads. See Figure - 03.
10. Mark then cut the cartridge stem $1\frac{1}{2}$ " from the surface of the finished wall. See Figure - 04.
11. Re-install the threaded tube onto the valve.
12. Hold the diverter plate† (SOLD SEPARATELY) and escutcheon (8) to finished wall then thread the gland cover (7) onto the threaded tube to hold the escutcheon and plate against the finished wall. Make sure the washer (9) is behind the escutcheon.
13. Remove the indice (2) and screw (4) from the handle (5) then place the handle over the cartridge stem in the desired orientation.

14. Thread the screw into the cartridge stem to fix the handle then re-install the indice.

➤ If further assistance is required, contact Product Support at 1-800-927-2120 (8am-6pm EST).

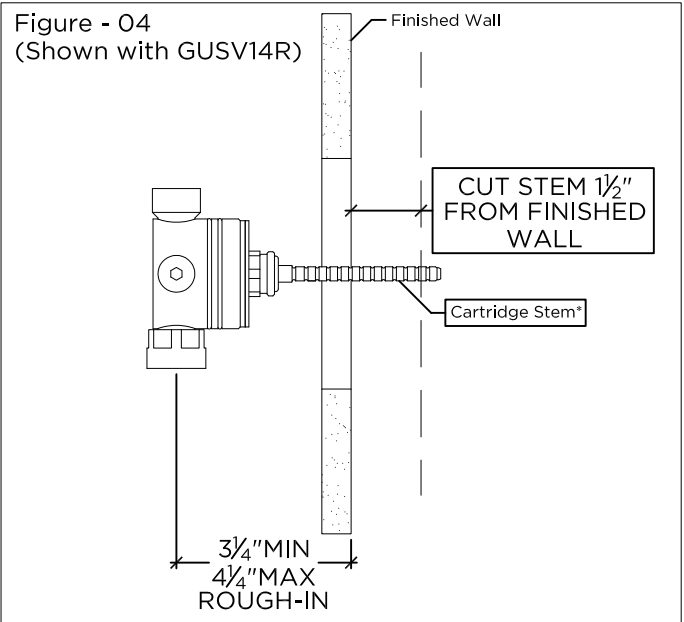
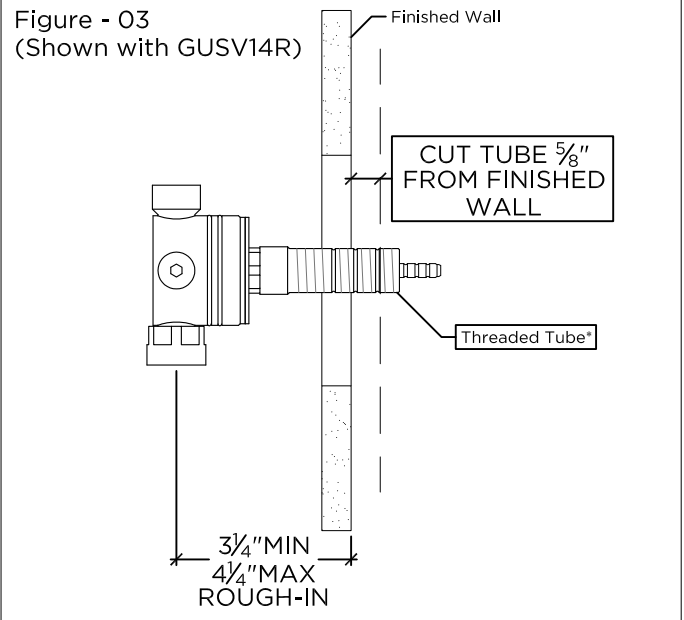

* If required a 1" stem extension kit is available.
STYLE No. 890831
ITEM No. 29-72873-53591

† **GUSV14R** requires the 2-Way Thermostatic Diverter Valve Trim (Plate Only): **STYLE No.** UNDV00

GUSV23R required the 2-Way Pressure Balance Diverter Valve Trim (Plate Only): **STYLE No.** UNDV10

These guidelines have been prepared for the professional contractor to aid in the installation of:
ROADSTER VOLUME CONTROL VALVE TRIM METAL CROSS HANDLE (STYLE No. RDVC40) AND METAL LEVER HANDLES (STYLE No. RDVC50).

All dimensions are based on origin specification and are subject to change and variation. Please consult your Design Associate for current specifications.

WATERWORKS
STUDIO

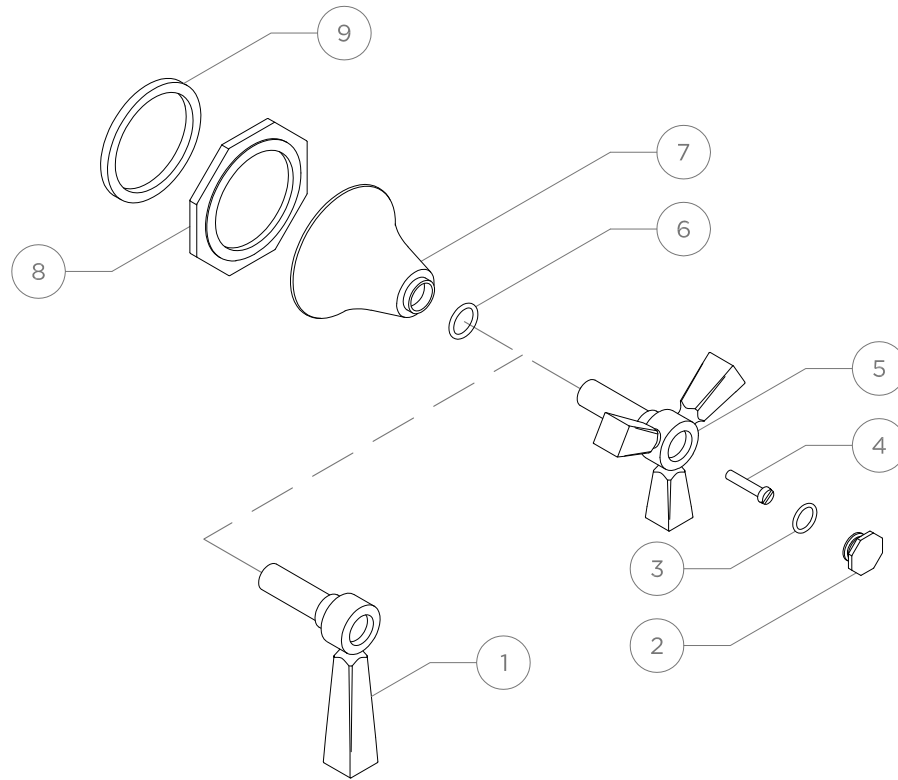

RDVC50 (Lever Handle)

ITEM NO.	DESCRIPTION	QTY.
1	Lever Handle, Roadster	1

RDVC40 (Tri-Spoke Handle)

5	Tri-spoke Handle, Roadster	1
---	----------------------------	---

COMMON PARTS

2	Indice, Roadster	1
3	O-Ring	1
4	Screw	1
6	O-Ring	1
7	Gland Cover, Roadster	1
8	Escutcheon, Roadster	1
9	Rubber Washer	1

These guidelines have been prepared for the professional contractor to aid in the installation of:
ROADSTER VOLUME CONTROL VALVE TRIM METAL CROSS HANDLE (STYLE No. RDVC40) AND METAL LEVER HANDLES (STYLE No. RDVC50).

All dimensions are based on origin specification and are subject to change and variation.
Please consult your Design Associate for current specifications.

WATERWORKS
STUDIO

WATERWORKS STUDIO

SERVICE PARTS

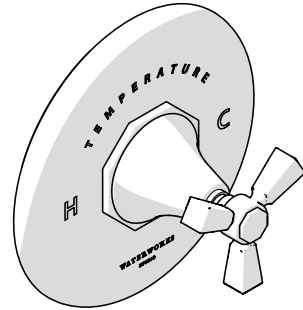

STYLE RDTH01
Roadster Thermostatic Control Valve Trim
with Metal Tri-spoke Handles

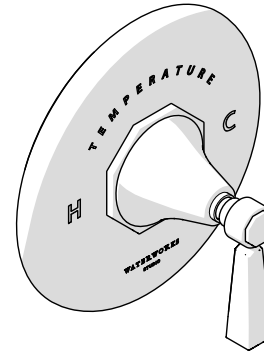

STYLE RDTH10
Roadster Thermostatic Control Valve Trim
with Metal Lever Handles

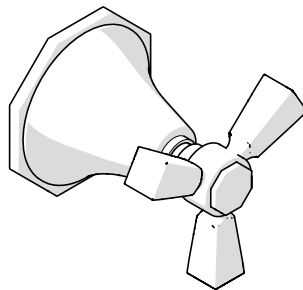

STYLE RDVC40
Roadster Volume Control Valve Trim with
Metal Tri-spoke Handles

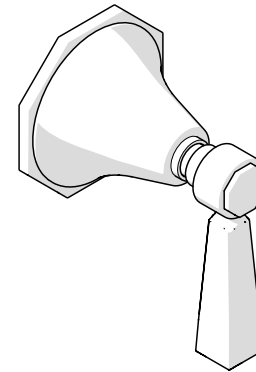

STYLE RDVC50
Roadster Volume Control Valve Trim with
Metal Lever Handles

WELCOME TO

WATERWORKS STUDIO

Over thirty years of experience distilled into signature fittings, surfaces, textiles, and accessories. Waterworks Studio is an edited collection of design solutions curated to be concise, engineered to be complete, and crafted for quality.

Everything you need, nothing more.

**TO ORDER PARTS CALL
1 (800) 927-2120 (EXT 2)**

Order by part number and specify color, finish, or other options if required.

PRODUCT SUPPORT

Our Product Support team provides troubleshooting and technical problem resolution, including replacement parts and installation recommendations throughout the life of your product.

Product Support is available Monday through Friday, 9am-6pm.

**LIMITED LIFETIME
WARRANTY**

Our warranty covers repair and replacement of Waterworks products if within the applicable coverage period and deemed defective by Waterworks. Waterworks will, at its option, repair or replace such products; this does not include installation costs, labor charges, or other incidental or consequential costs.

To obtain your complete warranty or inquire about warranty service, please visit us at www.waterworks.com or contact our Product Support Team.

MAIN KITS

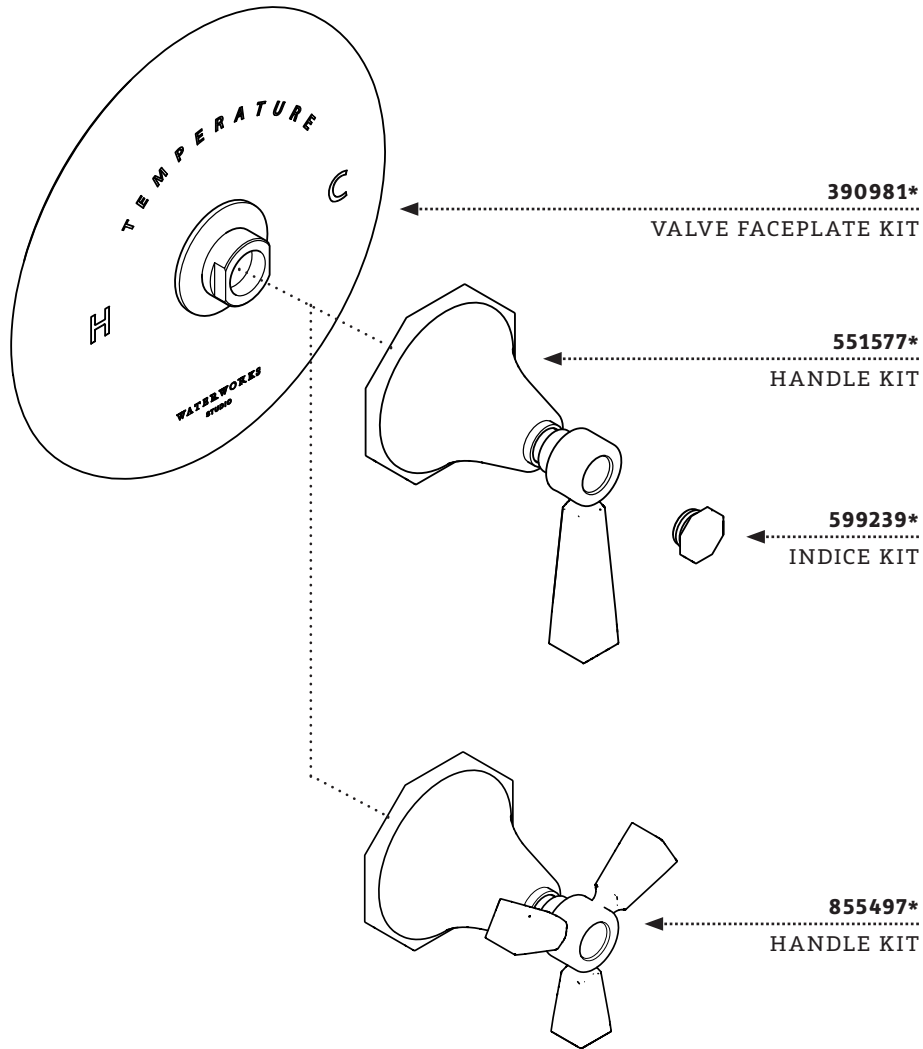

KIT COMPONENTS

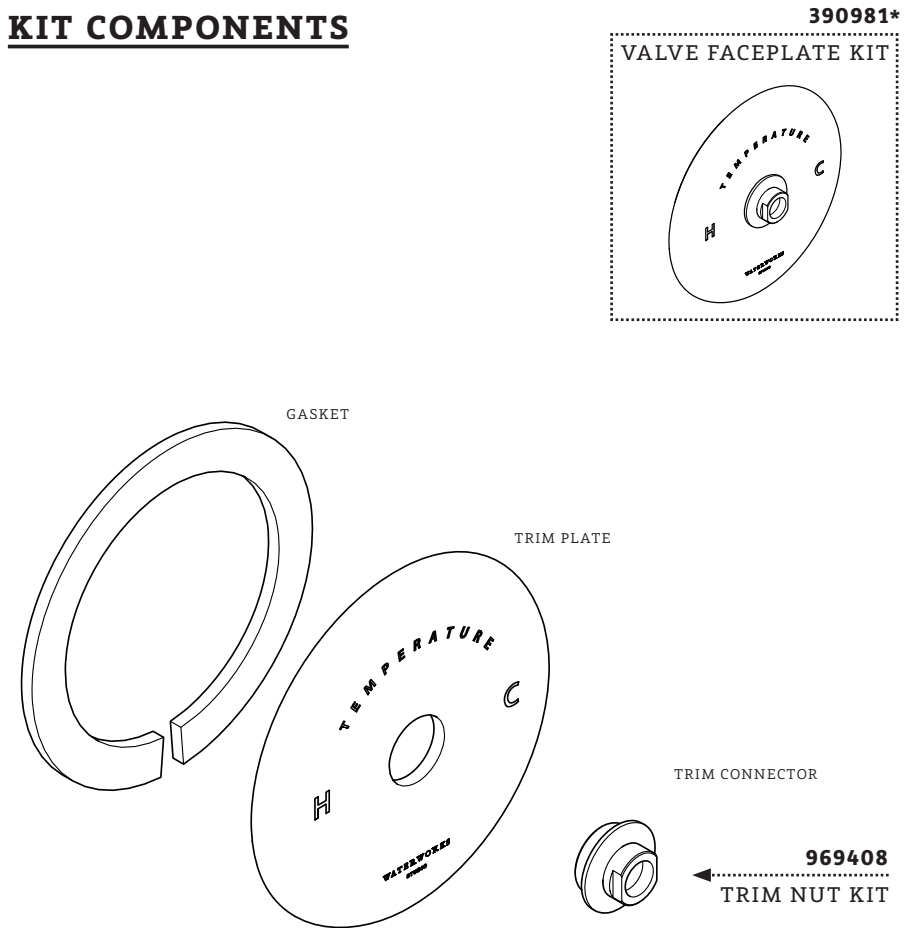

KIT COMPONENTS

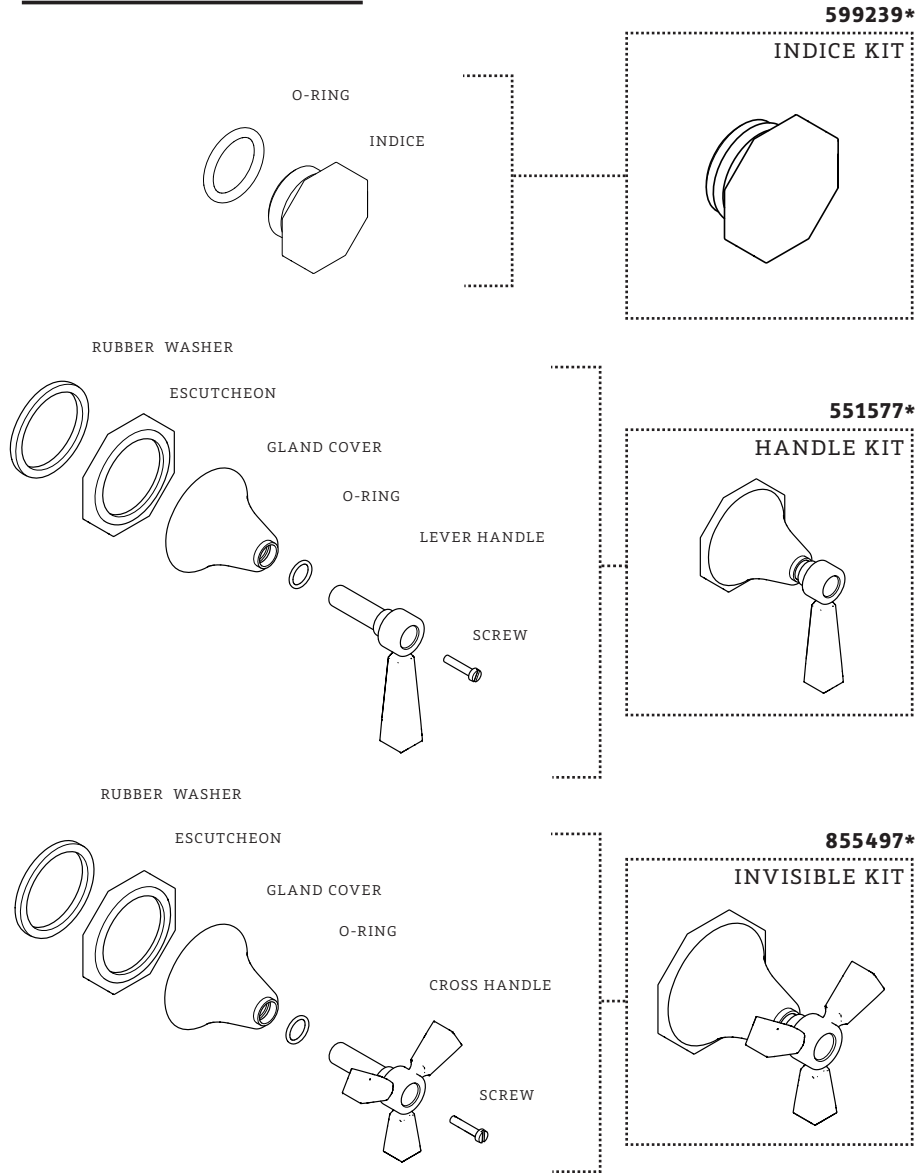

*FINISH/COLOR MUST BE SPECIFIED WHEN ORDERING
++SUPPLIED AS A PAIR

SERVICE PARTS INDEX

<u>STYLE</u>	<u>DESCRIPTION</u>	<u>PG</u>
551577*	HANDLE KIT	4
855497*	HANDLE KIT	4
599239*	INDICE KIT	4
969408	TRIM NUT KIT	3
390981*	VALVE FACEPLATE KIT	3

WATERWORKS
STUDIO

PRODUCT SUPPORT

60 BACKUS AVENUE
DANBURY, CT 06810

1 (800) 927-2120 (EXT 2)

WWW.WATERWORKS.COM/STUDIO