

INDUSTRIAL PREP SIZE TWO HANDLED PLP PULLDOWN / LEVER SPRAYER

9932

- **Max Counter Thickness 2-3/8"**
- **Minimum Install Hole Size 1-1/2"**

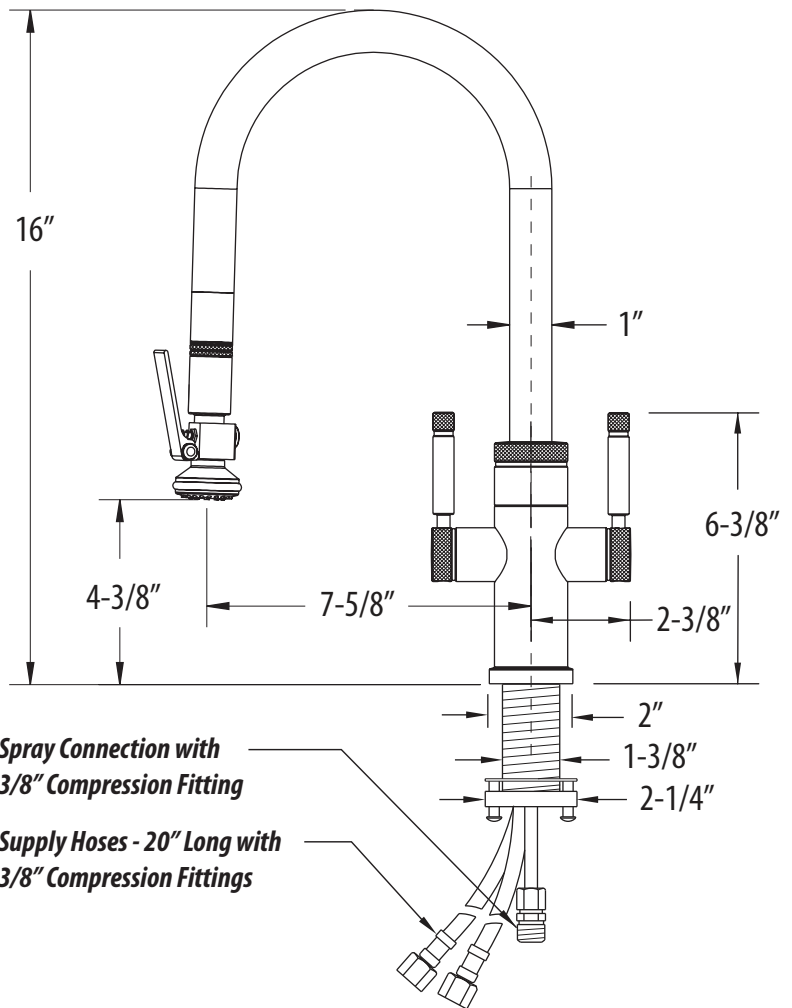
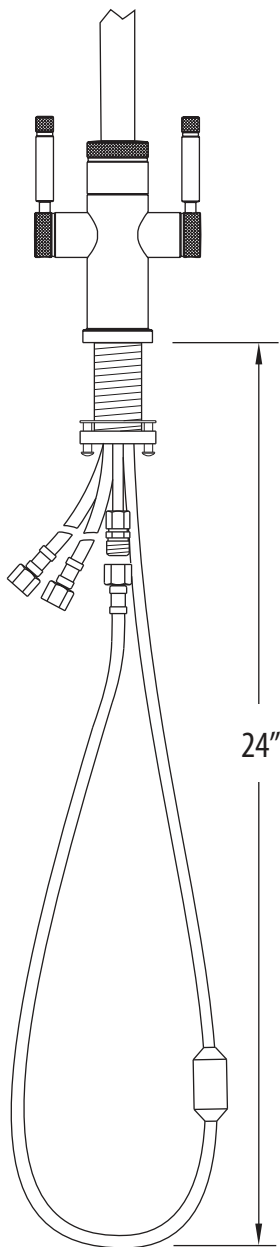

DIMENSIONS MAY VARY AND ARE SUBJECT TO CHANGE. NO RESPONSIBILITY IS ASSUMED FOR USE OF SUPERCEDED OR VOIDED DATA

