





- Half Stall Urinal.
- Mounting wall bracket included.
- Fitted with 3/4" top spud and 2" outlet spud.
- Wall bracket, 3/4" top spud and 2" outlet spud included.
- Available in white.
- Meets ADA  requirements.
- All Western products are IAPMO tested and meet or exceed  standards.
- Certified by IAPMO to meet or exceed the EPA WaterSense standards.



With Western the water savings are significant and maintenance is minimal.

For more information please contact us toll-free:

877-WPWORKS (979-6757)

US Sales and Service

Phone 562.229.0910 • Fax 562.229.0930

www.westernpottery.com • Email: info@westernpottery.com

14405 Best Avenue • Norwalk, California 90650

U493

PHYSICAL PROPERTIES

Model: **U493**
Half Stall Urinal

Water Consumption: **0.125 gpf or 0.5 gpf**

Height: **27-1/8" (689mm)**

Width: **18-7/16" (468mm)**

Depth: **13-3/4" (350mm)**

Mounting Hardware: **Wall bracket included**

Shipping Weight: **70 lbs**

Shipping Cube: **4.50 ft**

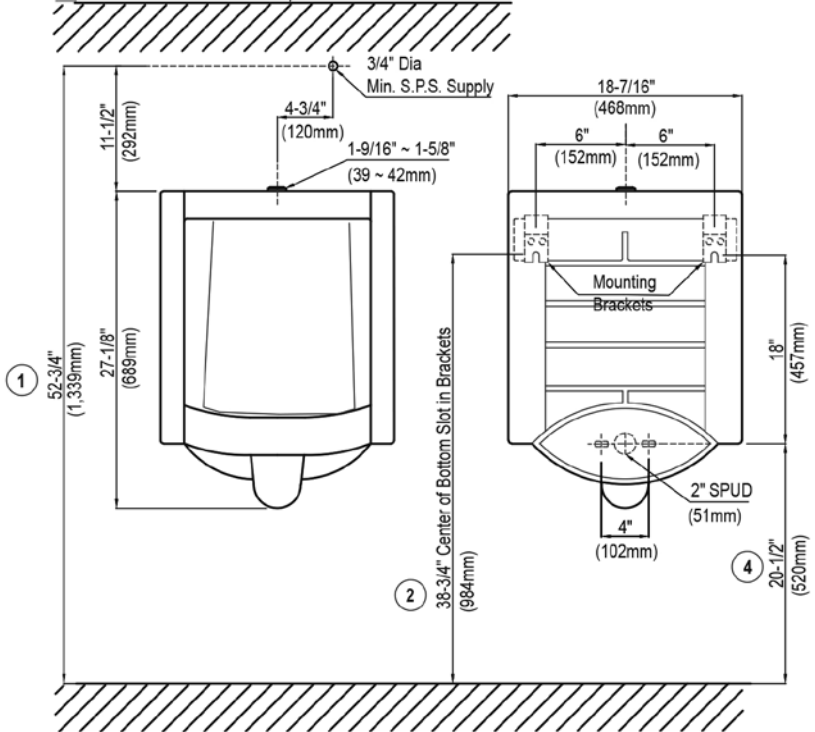
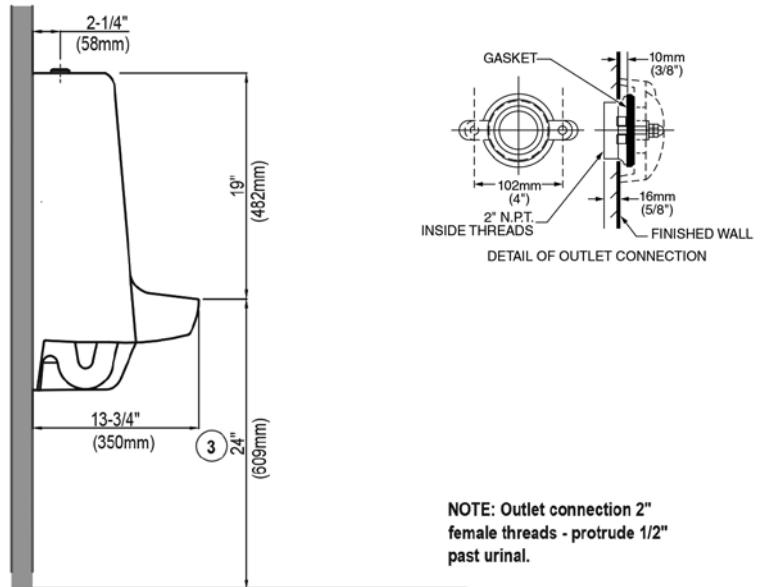

IMPORTANT: Dimensions are nominal and may vary within the range of tolerances established by ASME A112.19.2 / CSA B45.1. These measurements are subject to change without notice.



For more information please contact us toll-free:
877-WPWORKS (979-6757)
www.westernpottery.com • Email: info@westernpottery.com