

HENRY

HXT102

Henry Wall Mounted Exposed Tub Filler with Handshower and Two-Tone Cross Handles

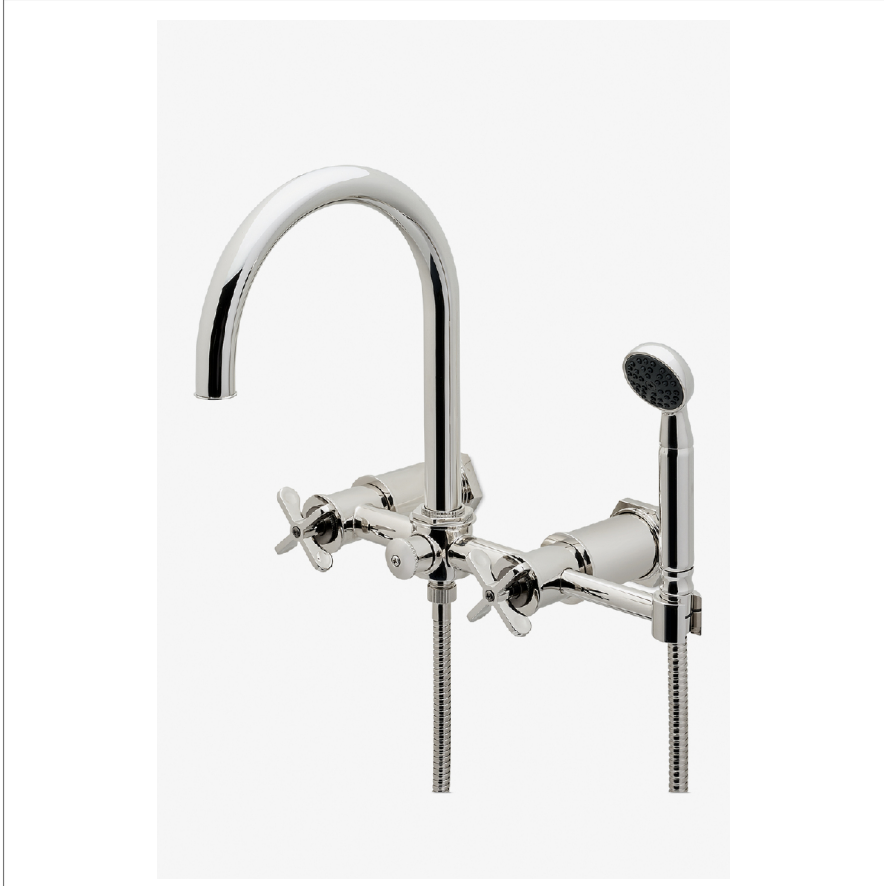

SHOWN IN HENRY WALL MOUNTED EXPOSED TUB FILLER WITH HANDSHOWER AND TWO-TONE CROSS HANDLES | HXT102

TECHNICAL DETAILS

ADA Compliance: No
Fittings Hole Diameter: 1 3/8"
Handle Spread Maximum: 8"
Handle Spread Minimum: 8"
Handle Turn Angle: Quarter Turn
Handshower Spray Hose Length: 60"
Inlet Connection Size: 3/4"
Inlet Connection Type: Copper Sweat, NPT and 1/2"
Female BSPP
Inlet Supply Spread Maximum: 8"
Inlet Supply Spread Minimum: 8"
Integrated Diverter: Y
Number Of Holes: Two Hole
Pivot: Y
Primary Material: Brass
Restricted Maximum Flow Rate: 1.75 gpm
Spout Swivel: N
Spray Included In Unit: Y
Valve Material: Brass and Ceramic
Water Pressure Maximum: 85.0 psi
Water Pressure Minimum: 20.0 psi
Water Pressure Recommended: 45.0 psi

INSPIRATION

Influenced by the connection of industry and art Henry easily transitions between modern, traditional, utilitarian and classic settings.

CODES & STANDARDS

PRODUCT FEATURES

Features Two Tone Cross Handles

Diverter Handle Allows Bather to Move Water From Spout to Handshower

Handshower Offers a Fixed Spray Pattern, Handshower Post Can Swivel to allow user to position Handshower over the tub

Stocked in Nickel/Dark Nickel and Brass/Dark Nickel

Unrestricted Flow for Tub Spout. Handshower Available in 1.75gpm (4.5L/min) Flow Rate

CERTIFICATIONS

PRODUCT (NOTES)

HENRY

HXT102

Henry Wall Mounted Exposed Tub Filler with Handshower and Two-Tone Cross Handles

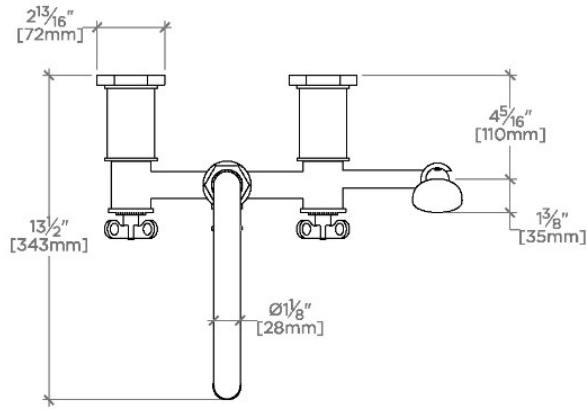

TOP VIEW

SCALE: 1/2"=1'-0"

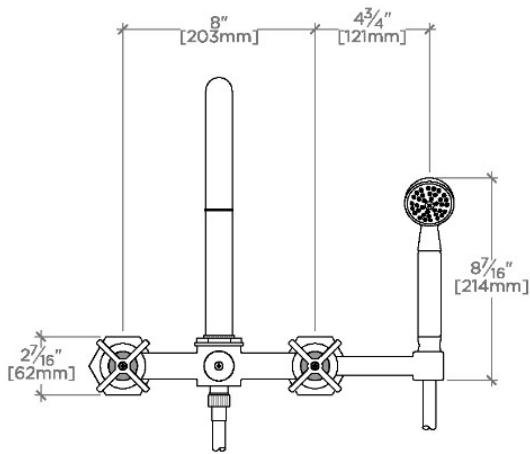

FRONT VIEW

SCALE: 1/2"=1'-0"

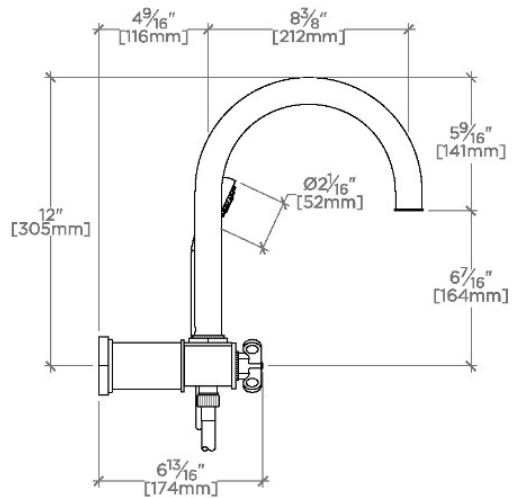

SIDE VIEW

SCALE: 1/2"=1'-0"