

INSTALLATION GUIDELINES

THERMOSTATIC SHOWER SYSTEM

WATERWORKS

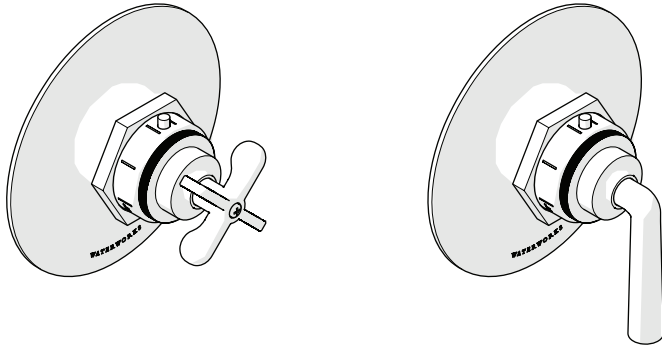

HENRY THERMOSTATIC CONTROL VALVE TRIM

STYLES			
HTH101 [SHOWN]	HTH102	HTH111 [SHOWN]	HTH112

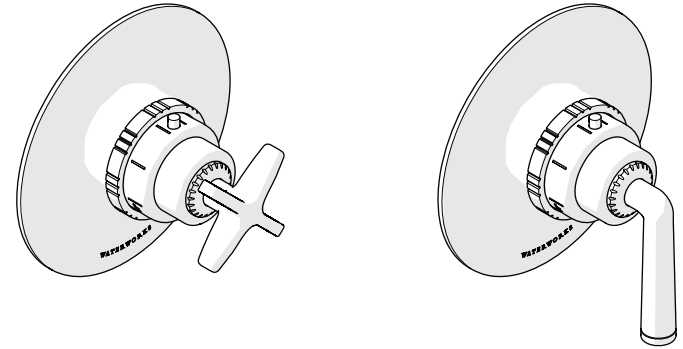

HENRY CHRONOS THERMOSTATIC CONTROL VALVE TRIM

STYLES			
CTH101 [SHOWN]	CTH111 [SHOWN]	CTH114	

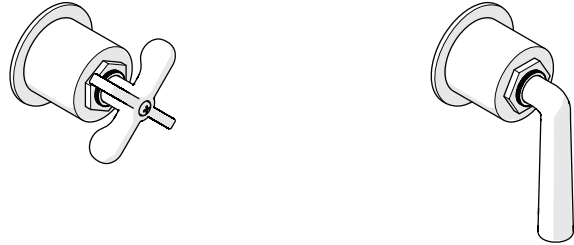

HENRY VOLUME CONTROL

STYLES			
HNVC01 [SHOWN]	HNVC02	HNVC03	HNVC11 [SHOWN]
HNVC12	HNVC13		

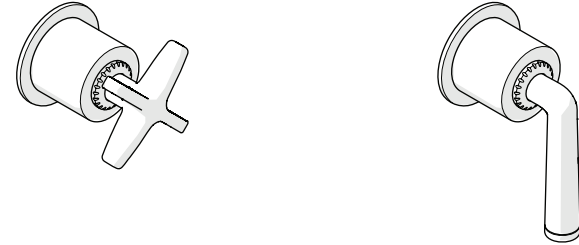

HENRY CHRONOS VOLUME CONTROL

STYLES			
CNVC01 [SHOWN]	CNVC11 [SHOWN]	CNVC14	

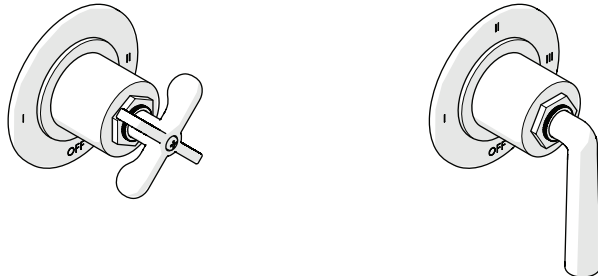

HENRY TWO & THREE WAY DIVERTER VALVE TRIMS

STYLES			
HN2T01 [SHOWN]	HN2T02	HN2T03	HN2T11
HN2T12	HN2T13	HN3T01	HN3T02
HN3T03	HN3T11 [SHOWN]	HN3T12	HN3T13

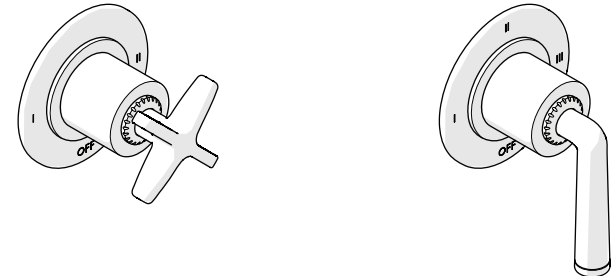

HENRY CHRONOS TWO & THREE WAY DIVERTER VALVE TRIMS

STYLES			
CN2T01 [SHOWN]	CN2T11	CN2T14	CN3T01
CN3T11 [SHOWN]	CN3T14		

INSTALLATION GUIDELINES

THERMOSTATIC SHOWER SYSTEM

IMPORTANT:

- **ALL VALVES AND TRIMS SOLD SEPARATELY.**
- To ensure these product are installed properly, you must read and follow these guidelines.
- The owner/user of these products must keep this information for future reference.
- These products must be installed by a professional licensed contractor and must be on-site prior to rough-in. This allows the installer to visualize the installation.
- Refer to the Installation Guidelines provided with each VALVE for complete rough-in installation details and related information.
- Be sure your installation conforms to all federal, state, and local codes. In the State of Massachusetts, all installations must comply with the rules and regulations set forth within 248 CMR.
- **WARNING:** The **THERMOSTATIC VALVES** (GUTH60/GUTH38) feature anti-scald protection. The risk of scalding exists until the installer has properly calibrated/adjusted the temperature setting during final TRIM installation.
- These products are sold partially assembled but shown fully disassembled for illustrative and service purposes only.
- Inspect these products to ensure you have all the parts required for proper installation.
- Use only a strap wrench or protected/smooth-jaw wrench on any finished surface.
- The use of certain plumber's putty may stain stone or tile surfaces.
- If further assistance is required, please contact Product Support at 1-800-927-2120 Monday through Friday, 8am - 6pm EST.
- Refer to the separate Service Parts Documents for available replacement parts.

VALVE FUNCTION:

- **THERMOSTATIC VALVES** only mix hot and cold water and do not have volume or shut-off capabilities.
- **VOLUME CONTROL VALVES** controls on/off/volume and must be installed for each fitting that will have water flowing to it or a **DIVERTER VALVE** for multiple fittings.

WATERWORKS



REQUIRED PLUMBING DETAILS:

- Depending on the number of end fittings in the shower system and how many are able to operate **SIMULTANEOUSLY**, the system will require either:

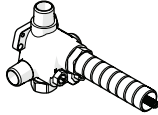
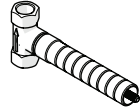
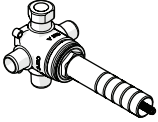
A. **GUTH60** system for a **MAXIMUM** of 2 fittings flowing simultaneously or,

		STYLE	NUMBER OF OUTLETS	INLET/OUTLET CONNECTIONS
THERMOSTATIC VALVE		GUTH60	2	1/2" MALE NPT
VOLUME CONTROL VALVE		GUVVC18	1	1/2" FEMALE NPT
		GUVVC19		
DIVERTER VALVE		GUDV2T [SHOWN]	2	1/2" MALE NPT
		GUDV3T	3	1/2" MALE NPT
		GUDV66	3	3/4" (IN) x 1/2" (OUT) FEMALE NPT

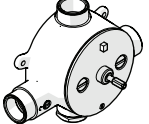
B. **GUTH37** system for 3+ fittings flowing simultaneously.

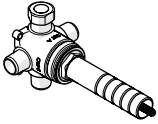
		STYLE	NUMBER OF OUTLETS	INLET/OUTLET CONNECTIONS
THERMOSTATIC VALVE		GUTH37	2	3/4" FEMALE NPT
VOLUME CONTROL VALVE		GUVVC16	1	3/4" FEMALE NPT
		GUVVC17		
DIVERTER VALVE		GUDV2T [SHOWN]	2	1/2" MALE NPT
		GUDV3T	3	1/2" MALE NPT
		GUDV66	3	3/4" (IN) x 1/2" (OUT) FEMALE NPT

INSTALLATION GUIDELINES

THERMOSTATIC SHOWER TRIM WITH GUTH60

WATERWORKS

ROUGH-IN AND VALVE PREPARATION:

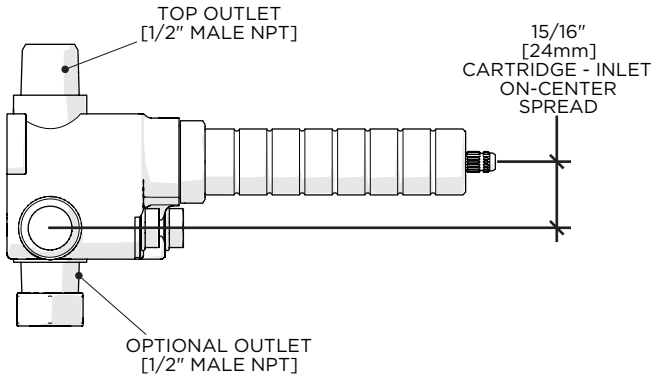

- **CAUTION:** The rough-in depth is measured from the centerline of the inlets to the surface of the finished wall. If the VALVE is roughed-in too shallow, the TRIM cannot be installed correctly.
- The VALVE is shipped with a pre-installed FLUSH PLATE and is ready for flushing the supply lines.
- **CAUTION:** Before installing the THERMOSTATIC CARTRIDGE, the supply lines **MUST BE** flushed out to prevent clogging of the FILTER SCREENS. Failure to flush the lines will permanently damage the CARTRIDGE and VOID the warranty. Repeat the flushing process as needed prior to final TRIM installation.
- Remove and discard the TILE GUARD only when the finished wall surface (TILE or SLAB) is completed and the TRIM is ready for installation.

DIMENSION	VALUE
A	4-1/2" [114mm] MAX 3-5/8" [92mm] MIN
B	Ø2-1/2" [64mm]

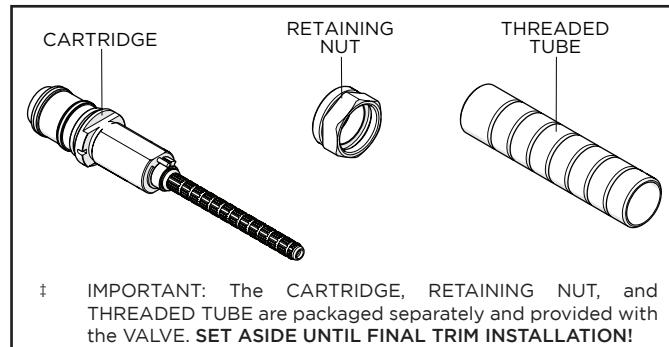
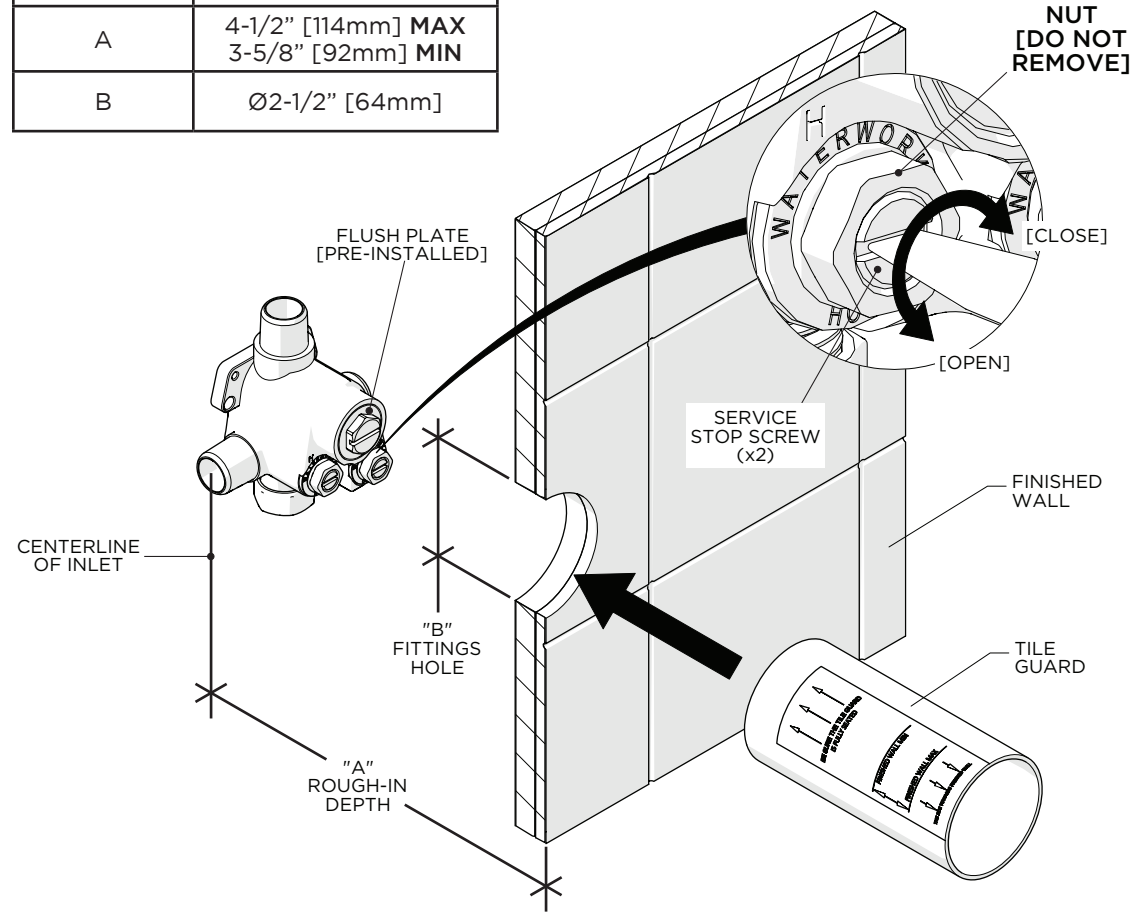

INSTALLATION GUIDELINES

THERMOSTATIC SHOWER TRIM WITH GUTH60

WATERWORKS

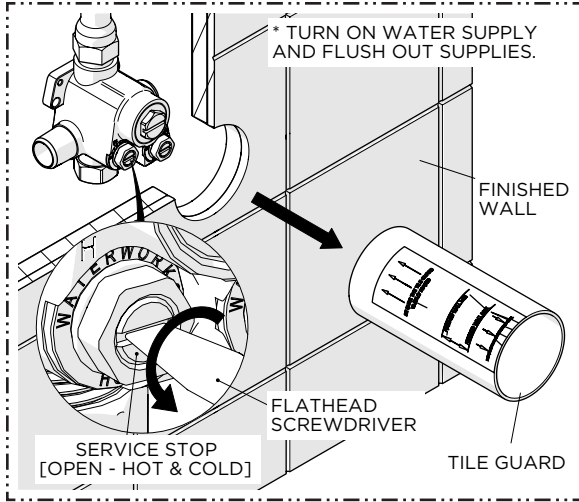

1. Turn on the water supplies then remove the TILE GUARD from the VALVE and **OPEN** the SERVICE STOPS (hot & cold) to flush out the lines.

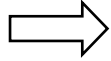

CAUTION: FAILURE TO FLUSH THE SUPPLY LINES WILL PERMANENTLY DAMAGE THE CARTRIDGE AND VOID THE WARRANTY! REPEAT THE FLUSHING PROCESS AS NEEDED BEFORE FINAL TRIM INSTALLATION.

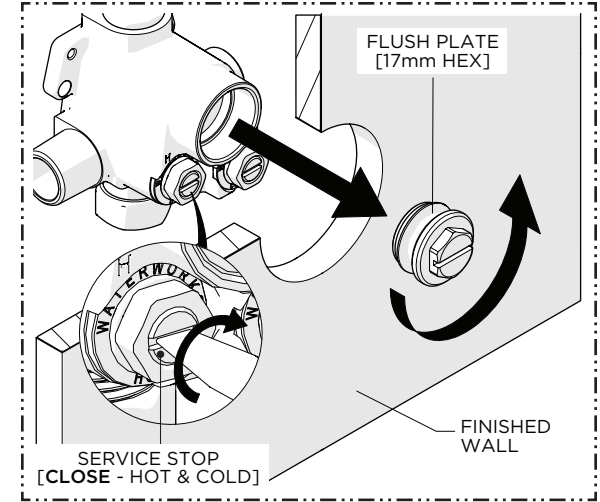
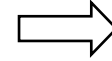

2. After the lines have been fully flushed, **CLOSE** the SERVICE STOPS (hot & cold) then unthread and remove the FLUSH PLATE.

NOTE: DO NOT discard the FLUSH PLATE.

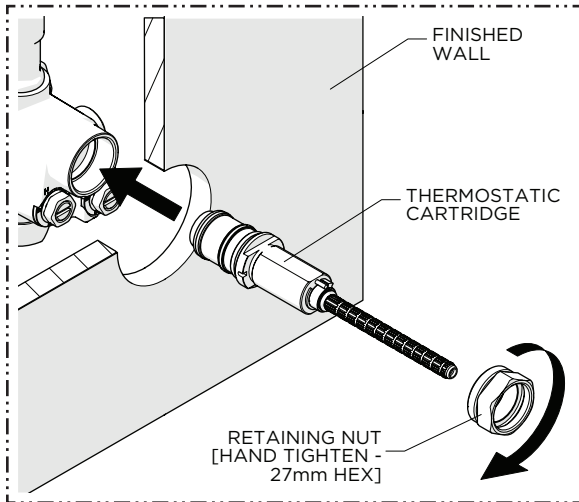

3. Insert the THERMOSTATIC CARTRIDGE into the VALVE BODY then thread and **hand-tighten** the RETAINING NUT into the VALVE BODY.

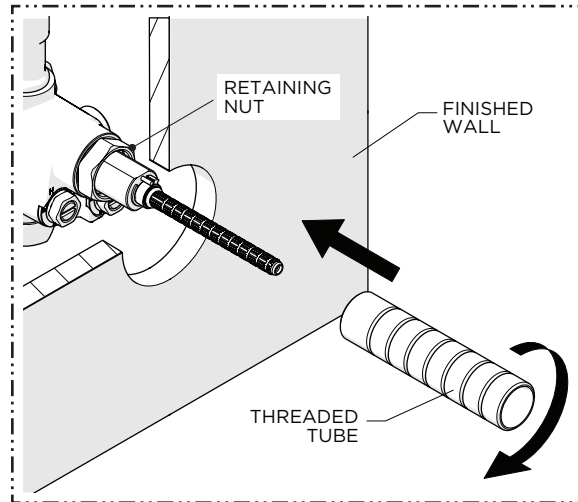
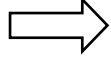

4. Thread the THREADED TUBE into the RETAINING NUT until snug.

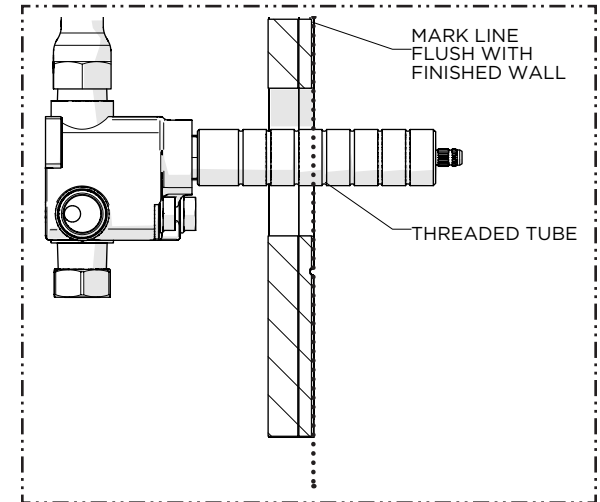
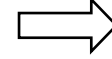

5. Mark the THREADED TUBE where it protrudes past the finished wall.

NOTE: A straight edge (not supplied) can be used to mark the TUBE.

INSTALLATION GUIDELINES

THERMOSTATIC SHOWER TRIM WITH GUTH60

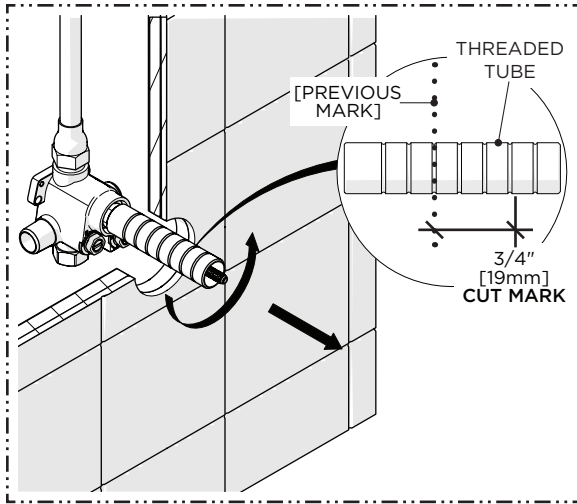

6. Remove the **THREADED TUBE** then cut it **3/4" [19mm]** in front of the previous mark so the TUBE will protrude 3/4" [19mm] from the finished wall surface.

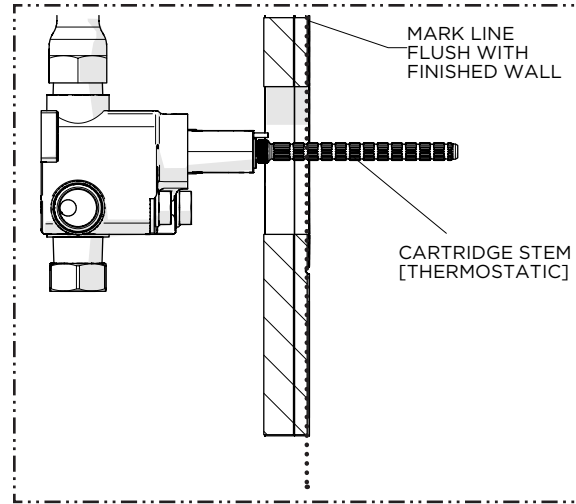

7. Mark the **CARTRIDGE STEM** where it protrudes past the finished wall.

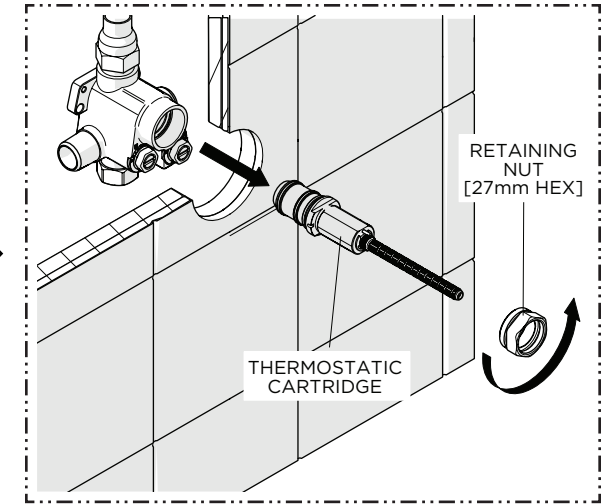

8. Unthread the **RETAINING NUT** and remove the **CARTRIDGE**.

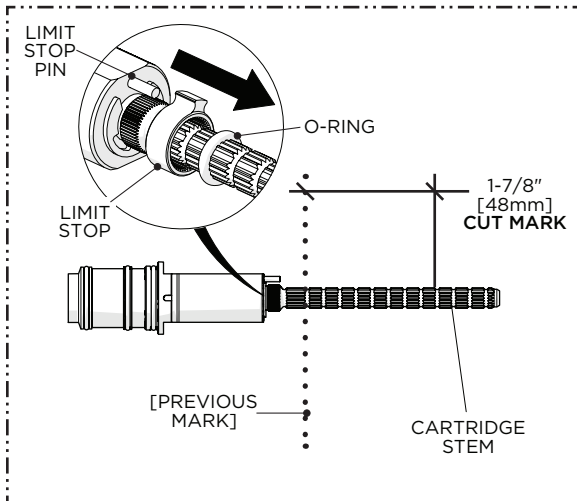

9. Carefully cut the **CARTRIDGE STEM** **1-7/8" [48mm]** in front of the previous mark so the STEM will protrude 1-7/8" [48mm] from the finished wall surface then remove the **O-RING** and **LIMIT STOP** from the **CARTRIDGE**.

NOTE: The **LIMIT STOP** is **NOT** required since the **TRIM PLATE** has a **LIMIT STOP**.

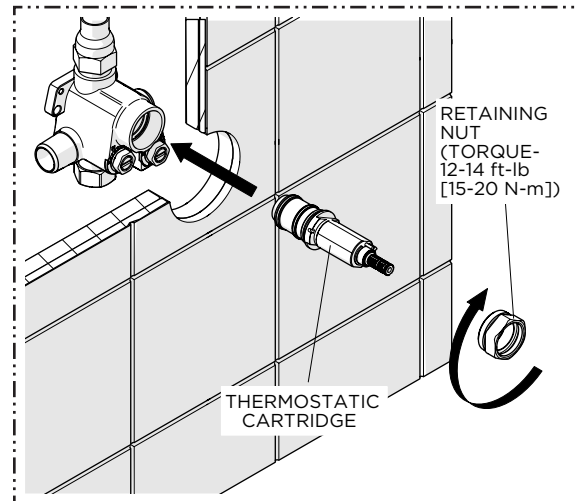

10. Insert the **CARTRIDGE** back into the **VALVE BODY**, thread and securely tighten the **RETAINING NUT** to the specified torque settings shown, and thread the **TUBE** back into the **NUT** until snug

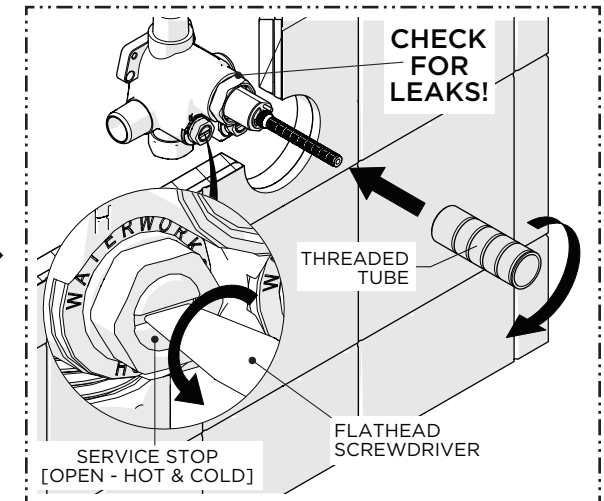

11. Open the **SERVICE STOPS** (hot & cold) and check for leaks then thread the **THREADED TUBE** back into the **RETAINING NUT** until snug.

➤ **PROCEED TO TRIM INSTALLATION ON PAGE 9.**

INSTALLATION GUIDELINES

THERMOSTATIC SHOWER TRIM WITH GUTH37

ROUGH-IN AND VALVE PREPARATION:

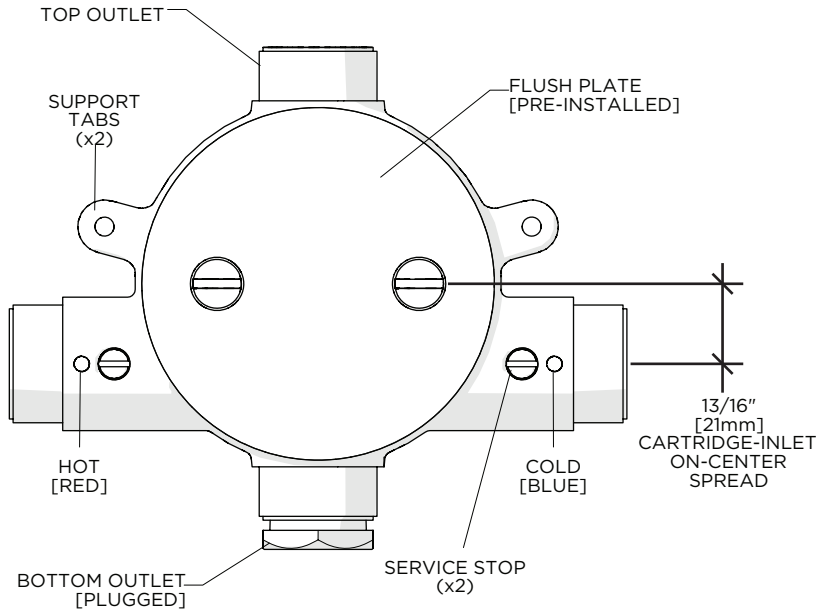

- **CAUTION:** The rough-in depth is measured from the centerline of the inlets to the surface of the finished wall. If the VALVE is roughed-in too shallow, the TRIM cannot be installed correctly.
- The VALVE is shipped with a pre-installed FLUSH PLATE and is ready for flushing the supply lines.
- **CAUTION:** Before installing the THERMOSTATIC CARTRIDGE, the supply lines MUST BE flushed out to prevent clogging of the FILTER SCREENS. Failure to flush the lines will permanently damage the CARTRIDGE and **VOID** the warranty. Repeat the flushing process as needed prior to final TRIM installation.
- Remove and discard the TILE GUARDS only when the finished wall surface (TILE or SLAB) is completed and the TRIM is ready for installation.

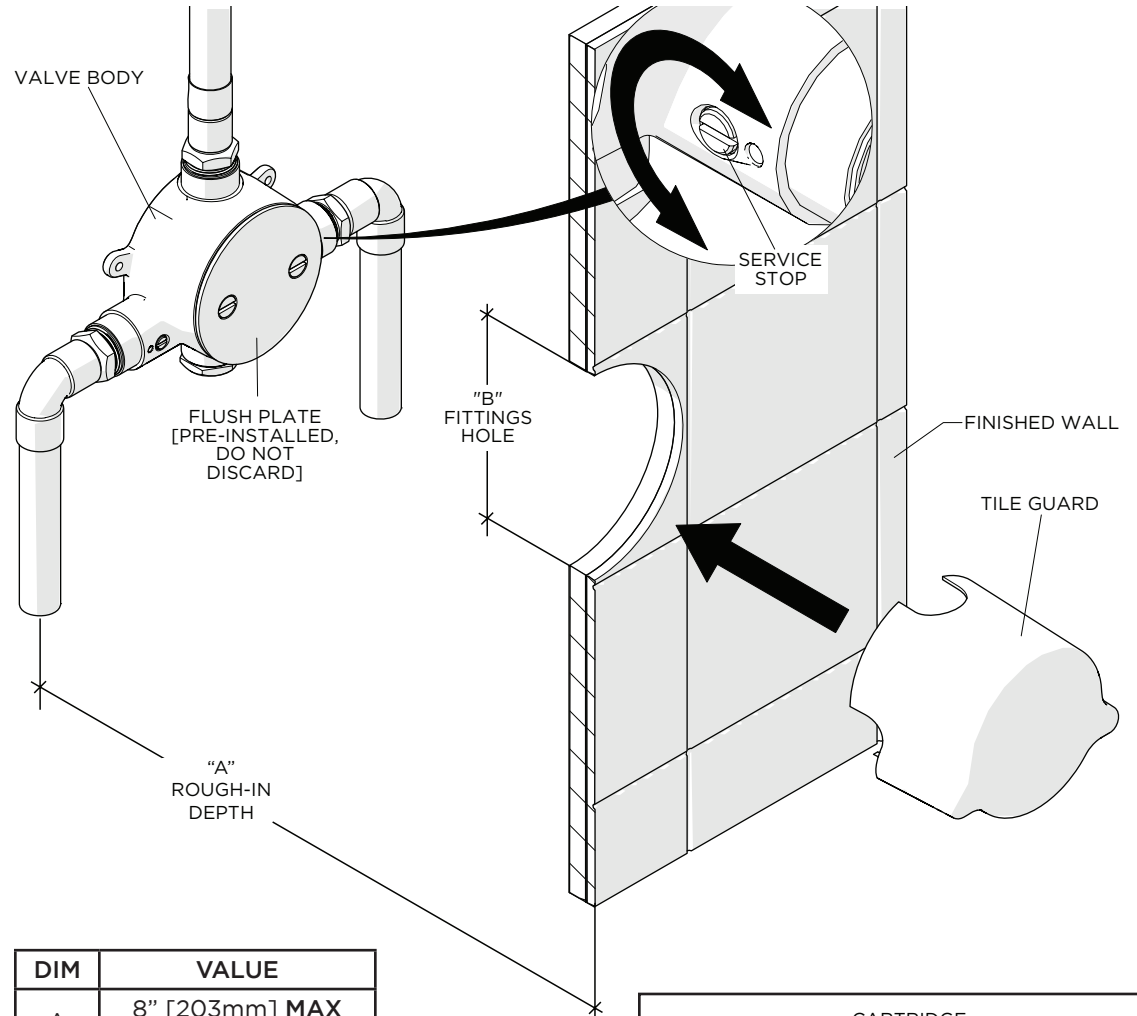

DIM	VALUE
A	8" [203mm] MAX 2-1/2" [64mm] MIN
B	Ø5-1/4" [133mm]

‡ IMPORTANT: The THERMOSTATIC CARTRIDGE is packaged separately and provided with the VALVE. SET ASIDE UNTIL FINAL TRIM INSTALLATION!

INSTALLATION GUIDELINES

THERMOSTATIC SHOWER TRIM WITH GUTH37

WATERWORKS

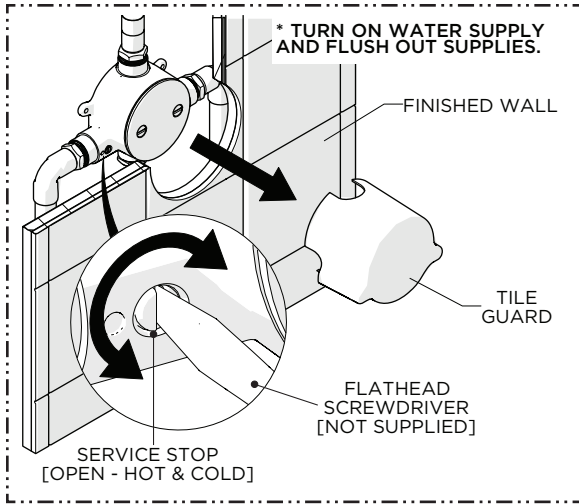

CAUTION: FAILURE TO FLUSH THE SUPPLY LINES WILL PERMANENTLY DAMAGE THE CARTRIDGE AND VOID THE WARRANTY! REPEAT THE FLUSHING PROCESS AS NEEDED BEFORE FINAL TRIM INSTALLATION.

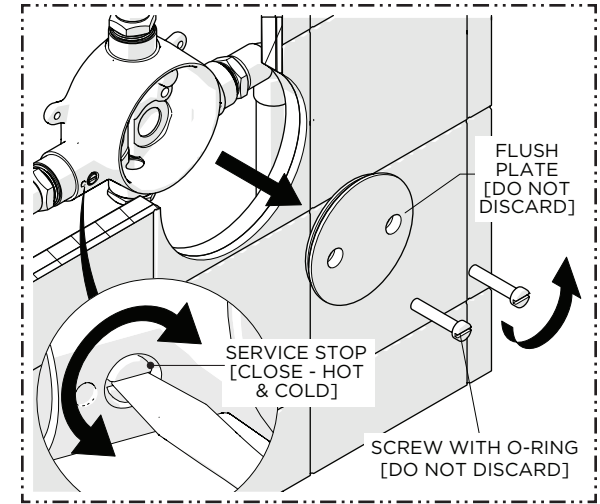

1. Turn on the water supplies then remove the TILE GUARDS from the VALVE and OPEN the SERVICE STOPS (hot & cold) to flush out the lines.

2. After the lines have been fully flushed, CLOSE the hot and cold SERVICE STOPS then unthread the SCREWS and remove the FLUSH PLATE.

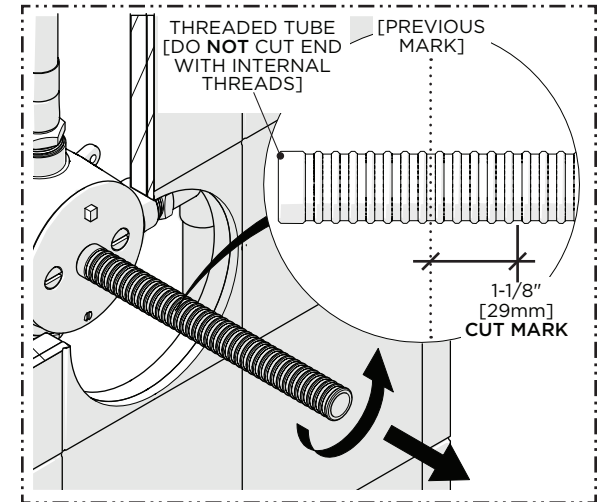
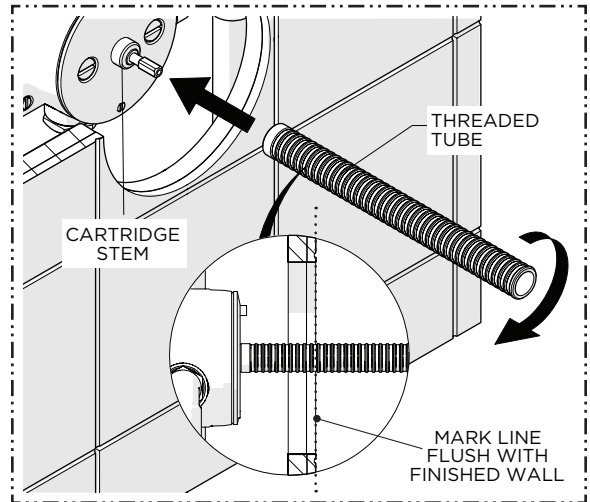
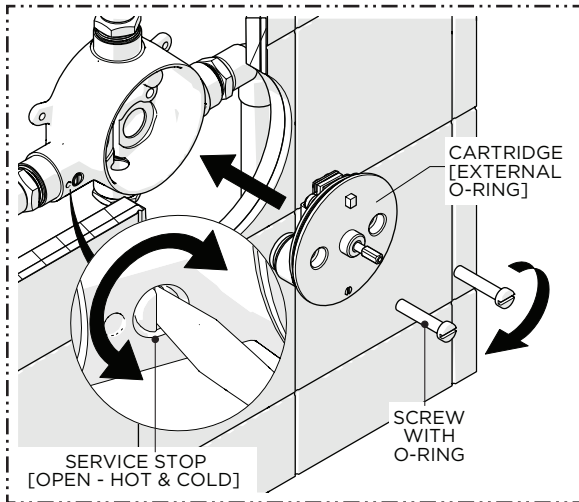

3. Insert the CARTRIDGE into the VALVE BODY then thread and securely tighten the SCREWS, re-open the SERVICE STOPS, and check for leaks.

4. Fully thread the THREADED TUBE onto the CARTRIDGE STEM and mark the TUBE where it protrudes past the finished wall.

5. Remove the THREADED TUBE then cut it 1-1/8" [29mm] in front of the previous mark so the TUBE will protrude 1-1/8" [29mm] from the finished wall surface.

NOTE: A straight edge (not supplied) can be used to mark the TUBE.

CAUTION: Do NOT cut the end with the internal threads.

INSTALLATION GUIDELINES

THERMOSTATIC SHOWER TRIM WITH GUTH37

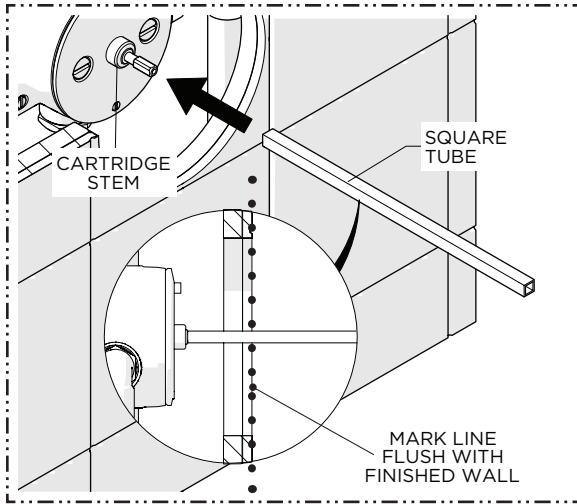

6. Insert the SQUARE TUBE onto the CARTRIDGE STEM and mark the TUBE where it protrudes past the finished wall.

NOTE: A straight edge (not supplied) can be used to mark the TUBE.

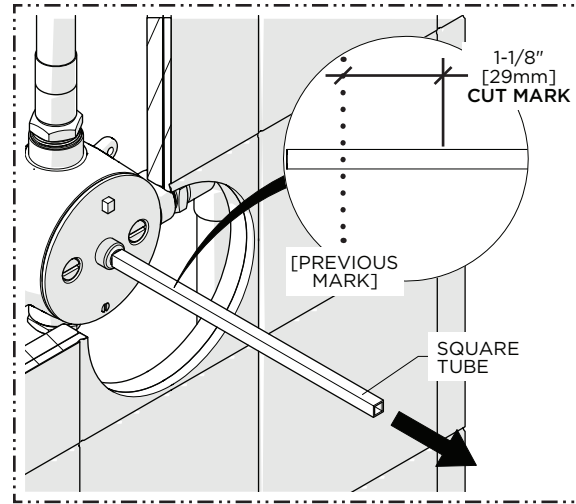
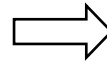

7. Remove the SQUARE TUBE then cut it 1-1/8" [29mm] in front of the PREVIOUS MARK so the TUBE will protrude 1-1/8" [29mm] from the finished wall surface.

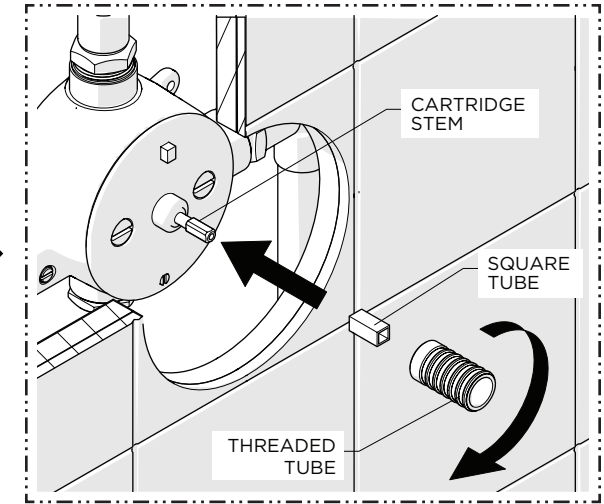
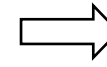

8. Slide the SQUARE TUBE onto the CARTRIDGE STEM then thread the THREADED TUBE onto the STEM until snug.

➤ **PROCEED TO TRIM INSTALLATION ON PAGE 9.**

INSTALLATION GUIDELINES

THERMOSTATIC SHOWER TRIM

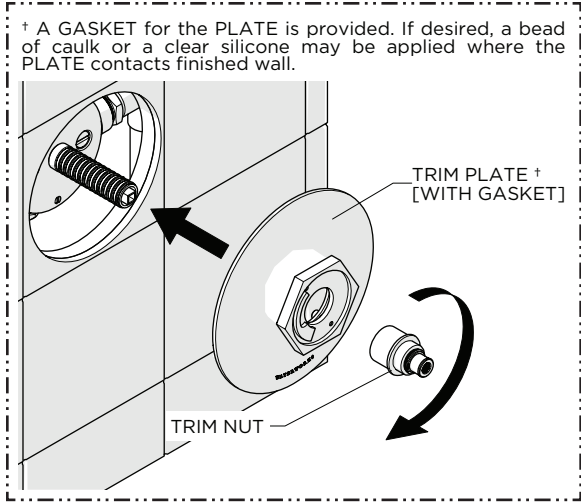

1. Firmly holding the TRIM PLATE against the finished wall, thread and securely tighten the TRIM NUT onto the THREADED TUBE.

NOTE: ROTATING THE ADAPTER STEM WILL HELP PROPERLY ALIGN IT WITH THE SQUARE TUBE USED ON THE GUTH37.

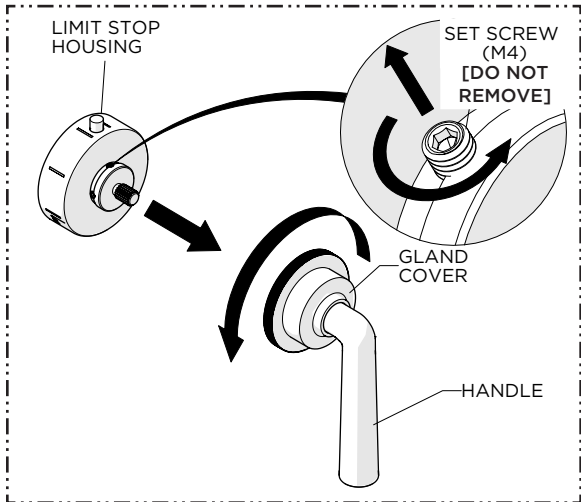

4. Unthread the GLAND COVER from the LIMIT STOP HOUSING to remove the HANDLE then loosen the SET SCREWS (x4) on the HOUSING.

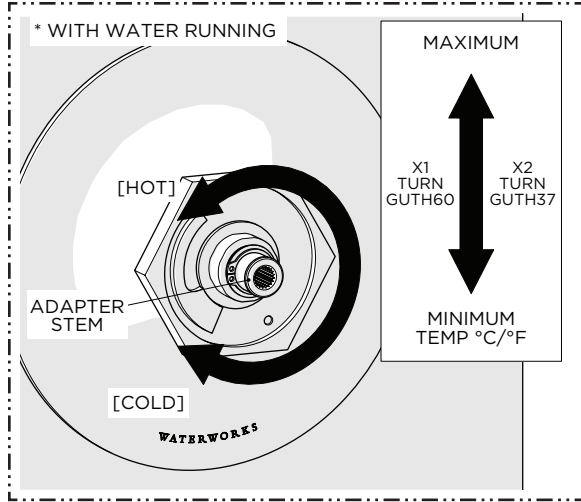

2. With water running, slowly rotate the ADAPTER STEM clockwise to attain full cold then rotate it counter-clockwise to attain full hot. Verify that a full range of temperatures exists.

NOTE: It's approximately 2 complete rotations for the GUTH37 and 1 rotation for the GUTH60.

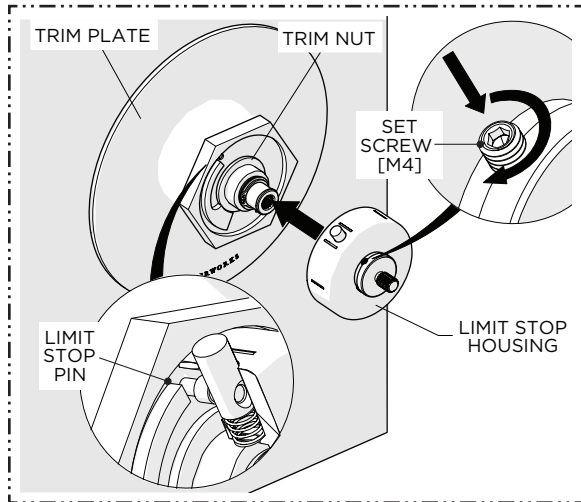

5. Slide the LIMIT STOP HOUSING onto the TRIM NUT making sure the LIMIT STOP PIN makes contact with the stop on the TRIM PLATE then tighten the SET SCREWS.

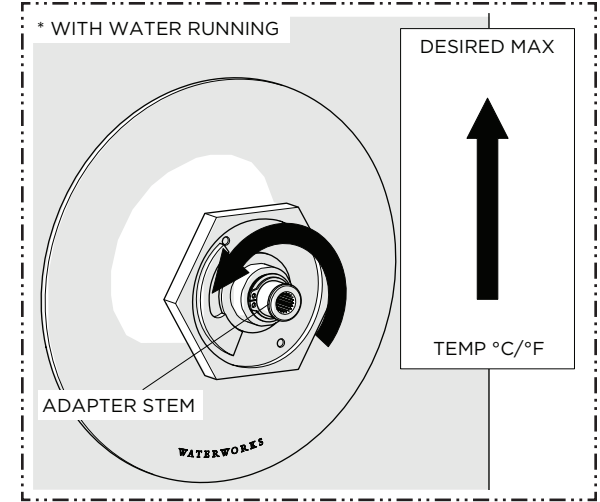

3. With water running, rotate the ADAPTER STEM to adjust the temperature to the **maximum** desired bathing temperature, verified with a thermometer, then turn the water off and make sure NOT to change this setting.

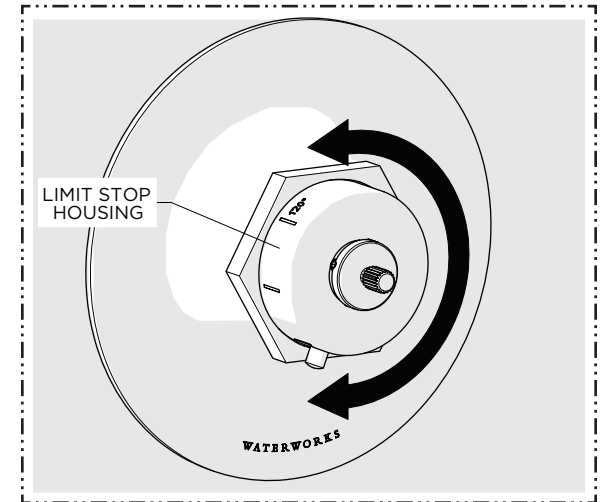

6. Turn the LIMIT STOP HOUSING clockwise to full cold then counter-clockwise until it stops and verify the **maximum** desired bathing temperature set in the previous step.

WARNING: It is **NOT** recommended to exceed a safety limit stop of 37.8°C/100°F.

INSTALLATION GUIDELINES

THERMOSTATIC SHOWER TRIM

WATERWORKS

CAUTION: IF THE MAXIMUM BATHING TEMPERATURE IS NOT CORRECT OR NEEDS TO BE ADJUSTED, REMOVE THE LIMIT STOP HOUSING AND REPEAT STEPS 2 THROUGH 6 TO RE-CALIBRATE THE TEMPERATURE SETTING

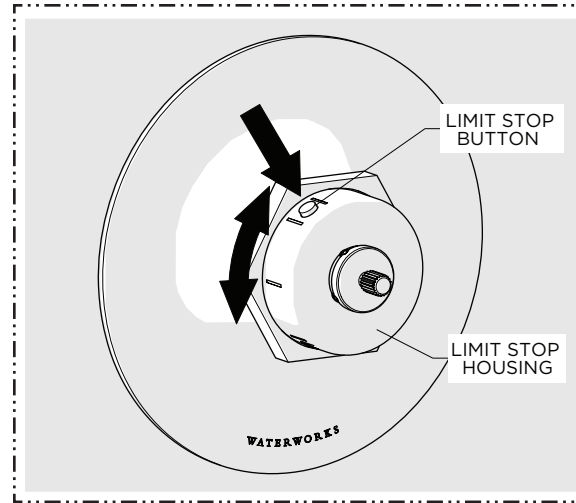
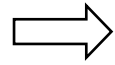

7. To get a hotter temperature, press and hold the LIMIT STOP BUTTON then rotate the LIMIT STOP HOUSING until it stops.

WARNING: It is **NOT** recommended to exceed a safety limit stop of 37.8°C/100°F.

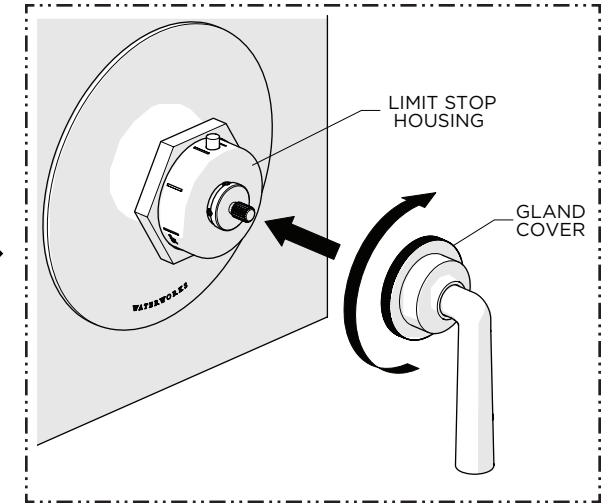
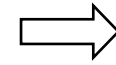

8. Thread and securely tighten the GLAND COVER back onto the LIMIT STOP HOUSING until snug.

INSTALLATION GUIDELINES

VOLUME CONTROL TRIM WITH GUVVC16/17/18/19

- **CAUTION:** The rough-in depth is measured from the centerline of the inlets to the surface of the finished wall. If the VALVE is roughed-in too shallow, the TRIM cannot be installed correctly.
- Remove and discard the TILE GUARD only when the finished wall surface (TILE or SLAB) is completed and the TRIM is ready for installation.

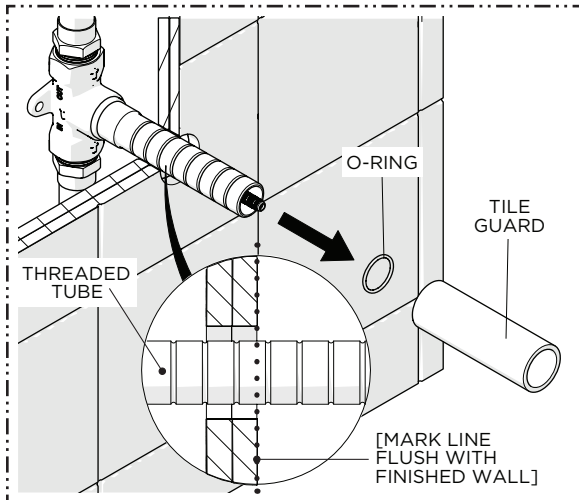
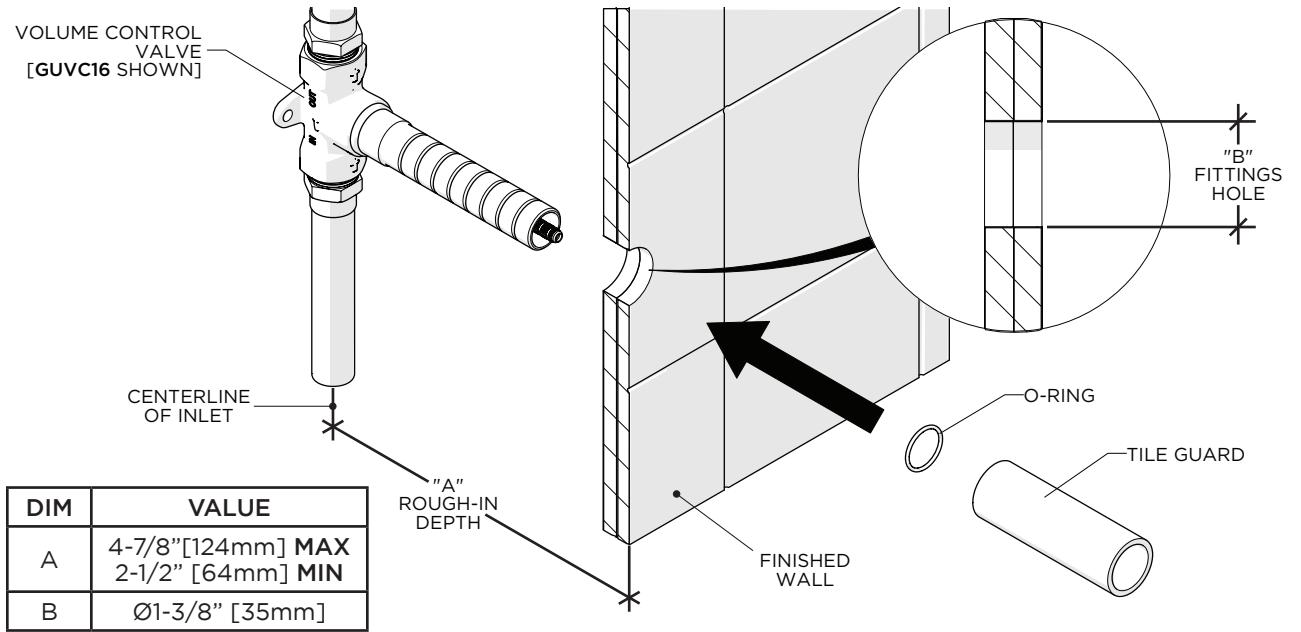

1. Remove the TILE GUARD when ready to install the TRIM then mark the THREADED TUBE where it protrudes past the finished wall.

NOTE: A straight edge (not supplied) can be used to mark the TUBE.

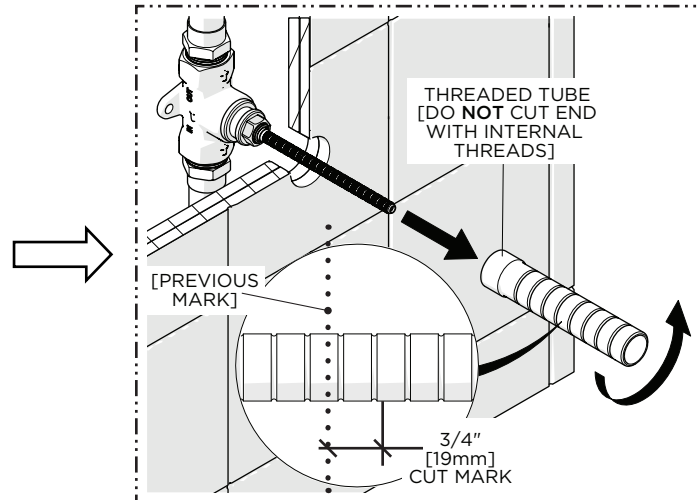

2. Remove the THREADED TUBE then cut it 3/4" [19mm] in front of the previous mark so the TUBE will protrude 3/4" [19mm] from the finished wall surface.

NOTE: Do NOT cut the end of the THREADED TUBE with the female threads.

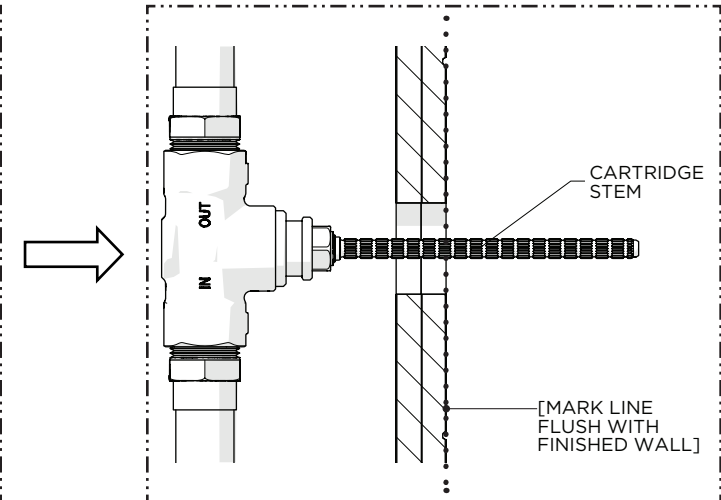

3. Mark the CARTRIDGE STEM where it protrudes past the finished wall.

NOTE: A straight edge (not supplied) can be used to mark the CARTRIDGE STEM.

INSTALLATION GUIDELINES

VOLUME CONTROL TRIM WITH GUVVC16/17/18/19

WATERWORKS

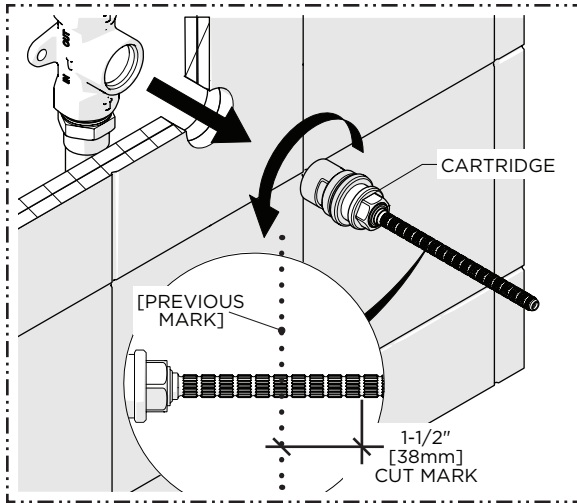

4. Remove the CARTRIDGE using a 21/32" [17mm] shower valve socket wrench (not supplied) then cut the CARTRIDGE STEM 1-1/2" [38mm] in front of the previous mark so the STEM will protrude 1-1/2" [38mm] from the finished wall surface.

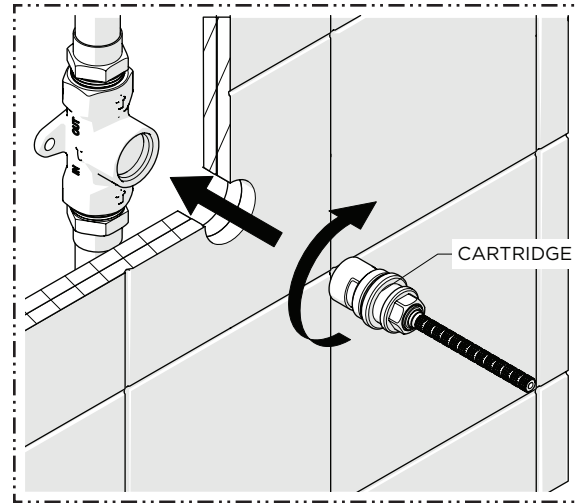
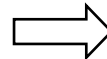

GUVVC18 & GUVVC19 ONLY:

5. Thread and securely tighten the CARTRIDGE back into the VALVE.

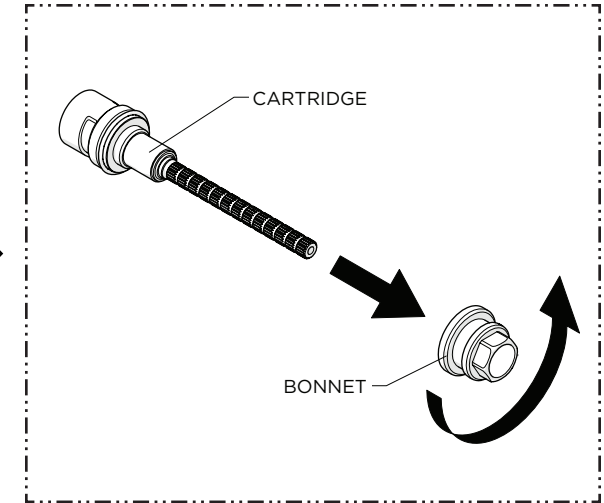
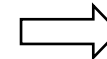

STEPS 6 - 10 GUVVC16 & GUVVC17 ONLY: HANDLE ALIGNMENT.

6. After cutting the CARTRIDGE STEM, unthread the BONNET from the CARTRIDGE if not already disassembled when removing from the VALVE.

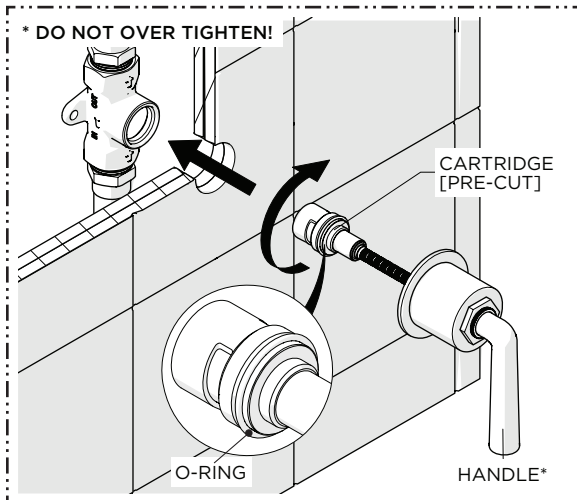

7. Using the HANDLE, thread the CARTRIDGE back into the VALVE until there is **NOTICEABLE** resistance.

NOTE: Ensure the O-RING on the CARTRIDGE has not been damaged and is properly seated.

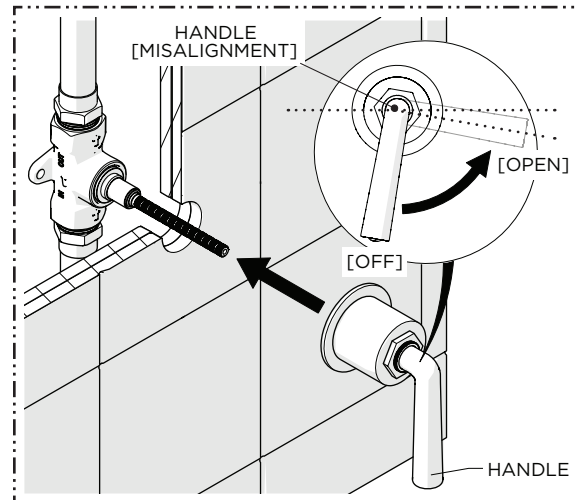
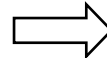

8. Remove and replace the HANDLE to position it as close as possible to the "OFF" position then turn the HANDLE a 1/4 turn to the "OPEN" position making sure **NOT** to unthread the CARTRIDGE.

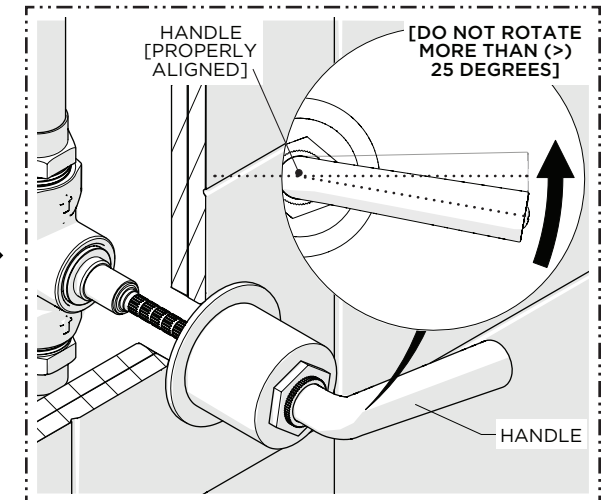
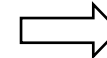

9. **If needed**, carefully continue to rotate the HANDLE counter-clockwise to obtain the proper alignment. Do **NOT** rotate/unthread the CARTRIDGE more than 25 degrees.

NOTE: Repeat Steps 7 & 8 if the CARTRIDGE is unthreaded too far.

INSTALLATION GUIDELINES

VOLUME CONTROL TRIM WITH GUV16/17/18/19

WATERWORKS

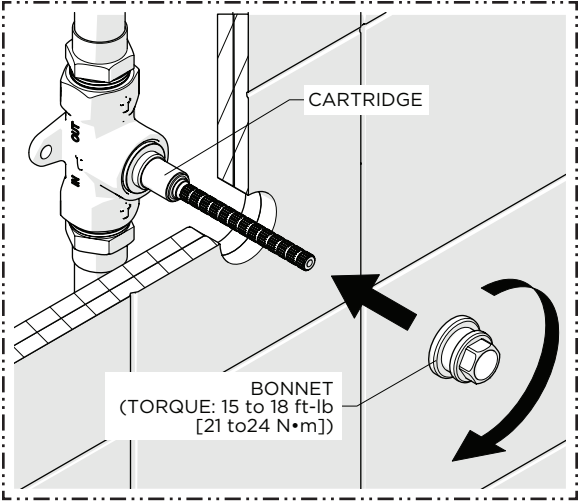

10. Remove the HANDLE then thread and securely tighten the BONNET back onto the CARTRIDGE.

NOTE: The BONNET requires a torque between 15 and 18 ft-lb [21-24 N•m].

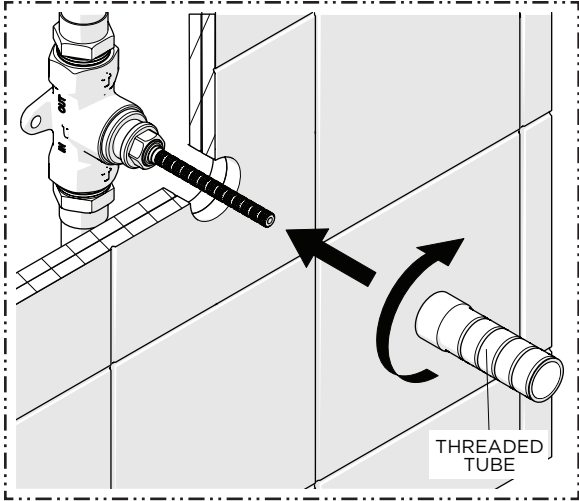
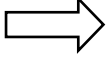

11. Thread and securely tighten the THREADED TUBE back onto the CARTRIDGE until snug.

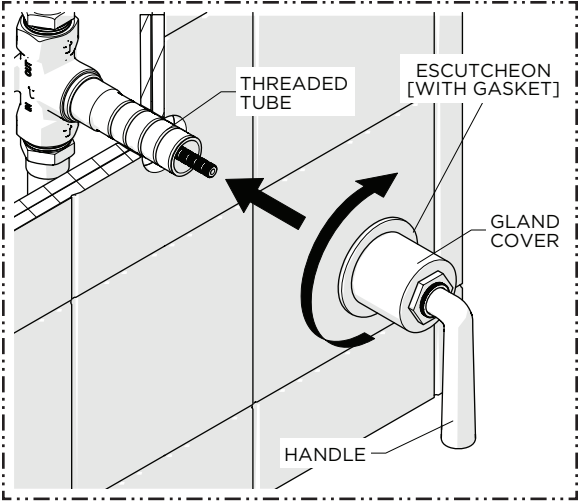
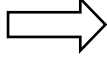

12. Using the FOAM WASHER provided and the HANDLE in the desired orientation, thread and securely tighten the GLAND COVER onto the THREADED TUBE.

INSTALLATION GUIDELINES

DIVERTER TRIM WITH GUDV2T/3T/66

- **CAUTION:** The rough-in depth is measured from the centerline of the inlets to the surface of the finished wall. If the VALVE is roughed-in too shallow, the TRIM cannot be installed correctly.
- The DIVERTER VALVE TRIM components (i.e. HANDLE and TRIM PLATE) are packaged separately from each other.
- Remove and discard the TILE GUARD only when the finished wall surface (TILE or SLAB) is completed and the TRIM is ready for installation.

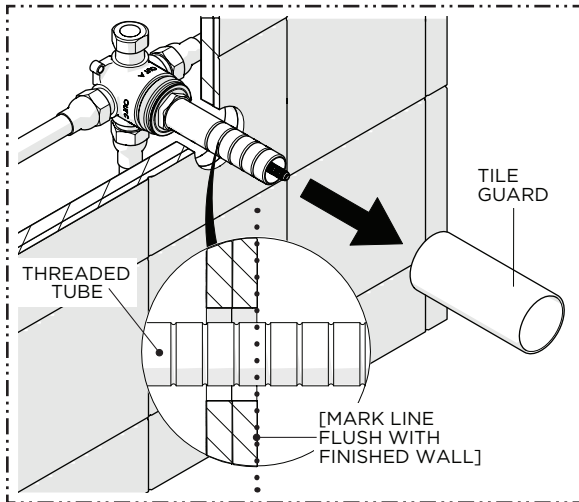
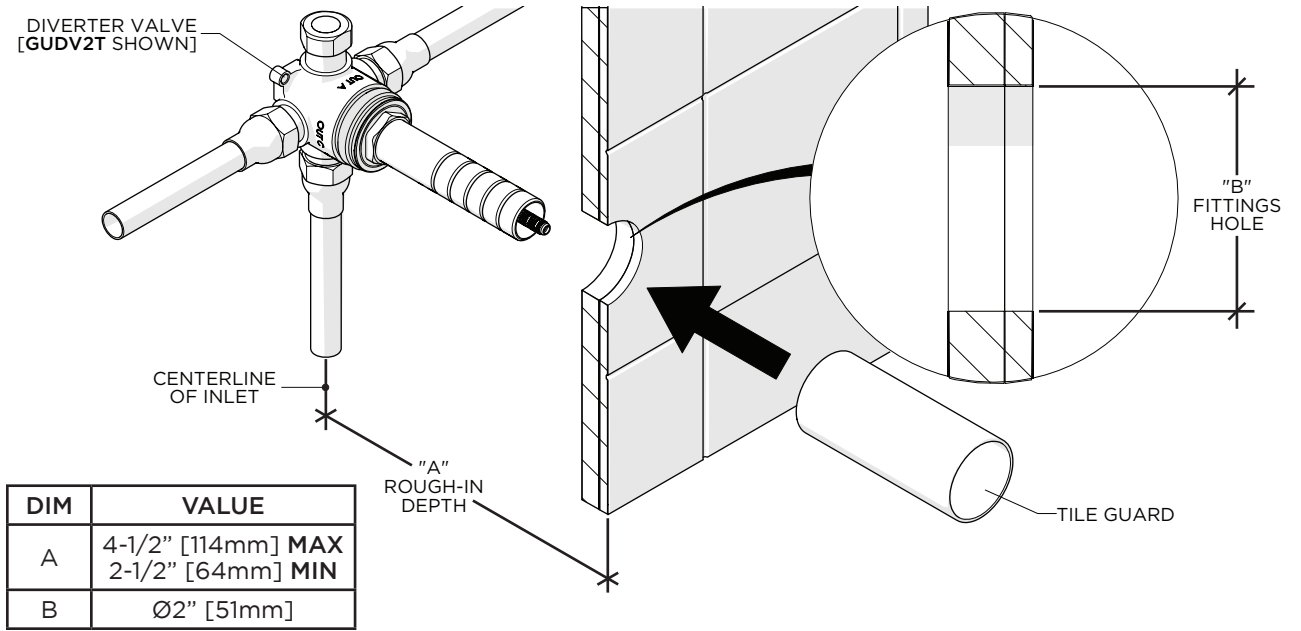

1. Remove the TILE GUARD when ready to install the TRIM then mark the THREADED TUBE where it protrudes past the finished wall.
NOTE: A straight edge (not supplied) can be used to mark the TUBE.

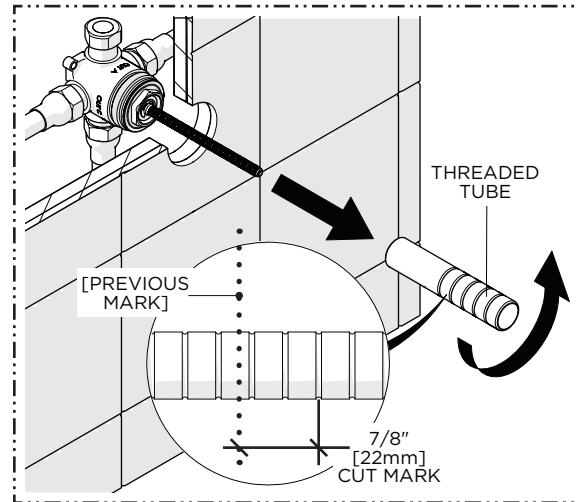

2. Remove the THREADED TUBE then cut it 7/8" [22mm] in front of the previous mark so the TUBE will protrude 7/8" [22mm] from the finished wall surface.

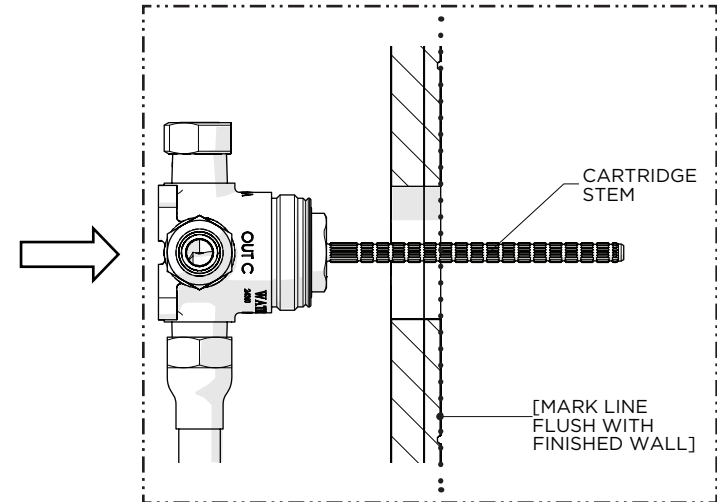

3. Mark the CARTRIDGE STEM where it protrudes past the finished wall.
NOTE: A straight edge (not supplied) can be used to mark the CARTRIDGE STEM.

INSTALLATION GUIDELINES

DIVERTER TRIM WITH GUDV2T/3T/66

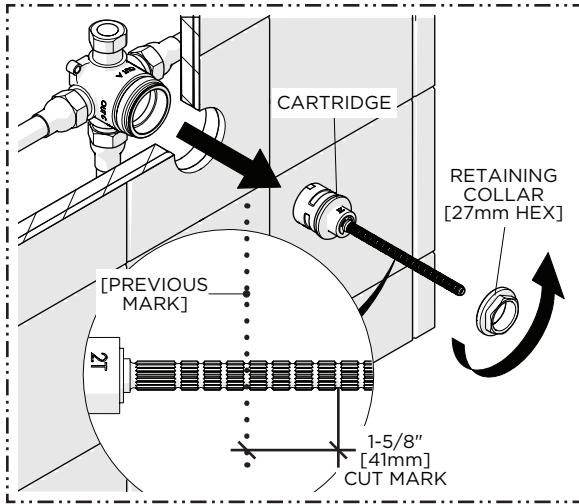

4. Unthread the RETAINING COLLAR and remove the CARTRIDGE then cut the CARTRIDGE STEM 1-5/8" [41mm] **in front** of the previous mark so the STEM will protrude 1-5/8" [41mm] from the finished wall surface.

NOTE (GUDV66 ONLY): Do **NOT** remove the CARTRIDGE, carefully cut the STEM.

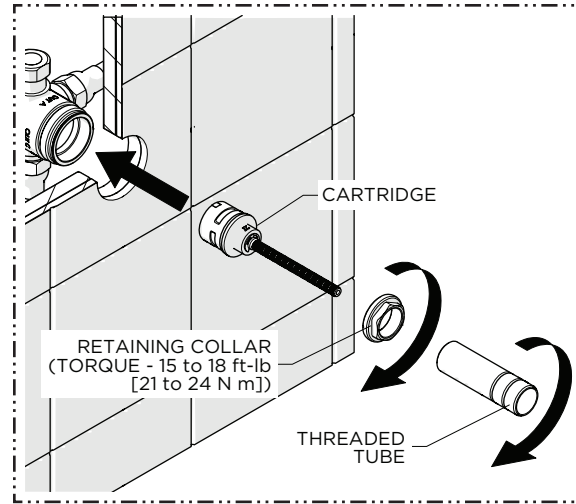
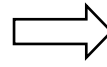

5. Re-insert the CARTRIDGE then thread and securely tighten the RETAINING COLLAR to the specified torque setting shown and thread the THREADED TUBE back into the RETAINING COLLAR until snug.

NOTE (GUDV66 ONLY): Thread the TUBE back onto the CARTRIDGE until snug.

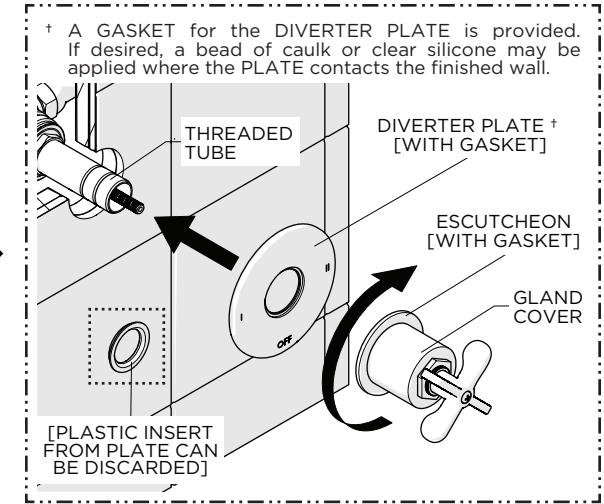
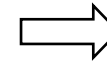

6. Firmly hold the DIVERTER PLATE against the finished wall then thread and securely tighten the GLAND COVER onto the THREADED TUBE making sure to use the GASKET provided.