

CONTENTS

1	Panel, mounting
6	Screw, #8-18 x 1/2"
6	Bumper, rubber
6	Screw, #8-32 x 3/8"

INTEGRATED FRONT PANEL INSTALLATION

- 1 Place the custom panel face down on a protected work surface.
- 2 Place the front mounting panel on the back of the custom panel (typically centered but varies with cabinetry design).
- 3 Use the mounting panel as a template to mark the six panel mounting locations.
- 4 Remove the mounting panel and use a 7/64" bit to drill six pilot holes.
- 5 Place the mounting panel on the back of the custom panel and use the predrilled holes to align.
- 6 Trace the remaining circular holes and each set of upper and lower oblong holes.
- 7 Remove the mounting panel and use a 1/2" bit to counter-bore 1/4" deep holes in each circular hole.

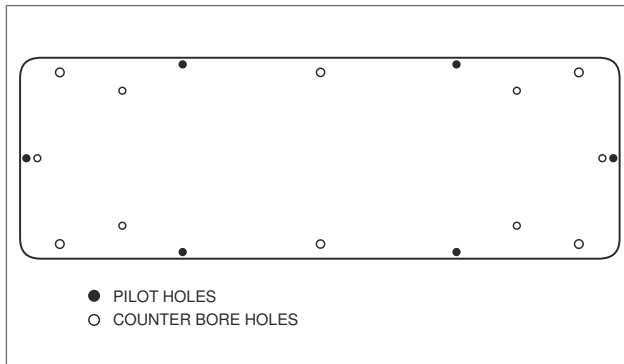

- 8 Remove the four screws from the front of the drawer and discard the cardboard panel.

- 9 Remove the protective material from the mounting panel and insert six rubber bumpers. The round side of the bumpers should face the protected side.

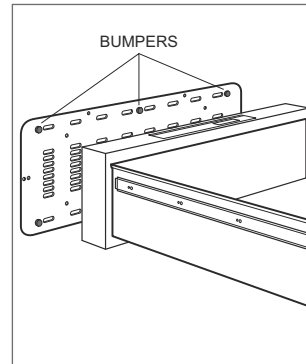

- 10 Install the mounting panel using six 3/8" screws.

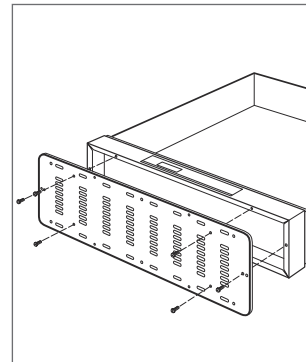

- 11 Align the pilot holes on the custom panel with the holes on the mounting panel and attach using 1/2" screws.

