



Induction Range Riser Installation

wolfappliance.com 800.222.7820

CONTENTS

1	Panel, front
1	Panel, back
2	Support, side
1	Support, center
4	Foam
21	Screw, #8 x 1/2"

Note: Additional screws are provided but not used.

INDUCTION RANGE RISER INSTALLATION

- 1 Place the front panel face down on a protected work surface, then remove the protective material from the back of the panel.
Note: Limit the amount of protective material removed to ensure the stainless steel is protected throughout the assembly process.
- 2 Insert the side supports into the riser assembly and secure using two #8 x 1/2" screws per side.

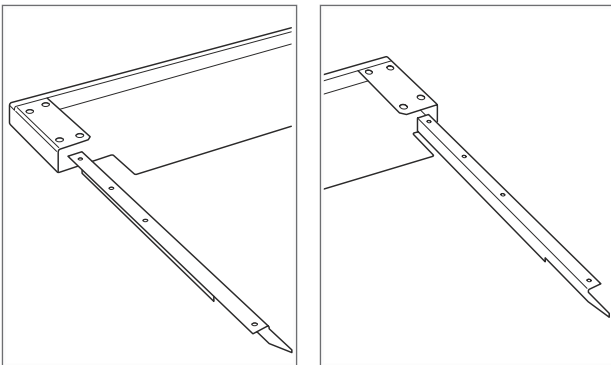

- 3 Remove the paper backing from two of the foam pieces, then adhere each to another piece of foam to create two (square) blocks.
- 4 Remove the paper backing from the two foam blocks.

- 5 Install both blocks (centered) between the side supports and centerline of the front panel.

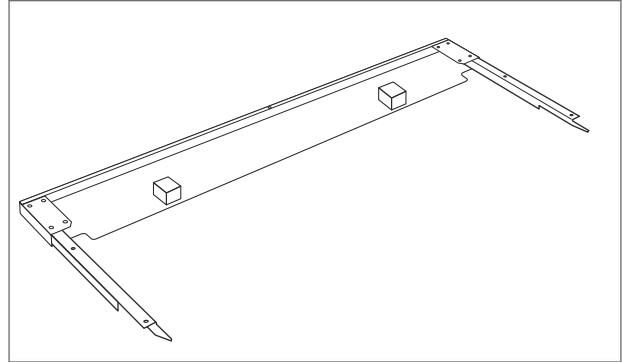

- 6 Place the center support bracket on a protected work surface, then place the back panel on the center support and install one #8 x 1/2" screw in the back panel bottom hole.

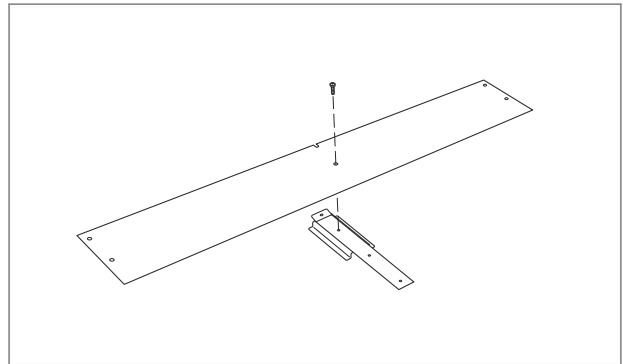

- 7 Remove the paper backing from the black tape on the center support flanges, then align the center support hole with the center hole on the front panel.
Note: Angle the center support slightly to ensure the tape doesn't adhere before the support is properly aligned with the center hole.
- 8 Press the center support to secure the tape to the front panel, then secure the back panel to the front panel using five #8 x 1/2" screws.

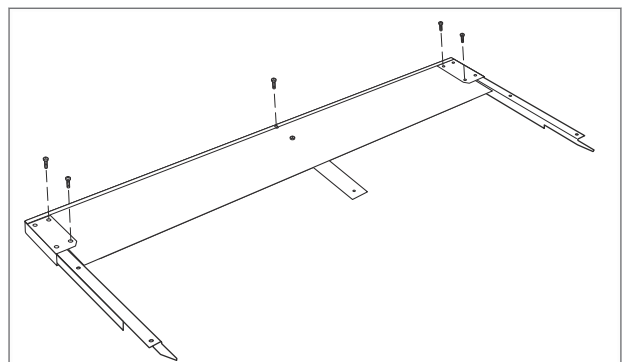



- 9 Remove the island trim from the range by extracting the screws along the top and both sides.
- 10 Install the new riser.
Note: The foam blocks are designed to prevent gaps between the cooking surface and riser. The foam blocks may need to be compressed slightly while the riser is installed.
- 11 Once the riser is installed, insert two screws through the back of the range and into the right, left and center supports.