

MD034 31.5x17.7

Height: 31.5
Width: 17.7
Depth: 3.2 - 3.7
Weight HO: 12.1lbs (5.5kg)
EO: 20.9lbs (9.5kg)

Tube ϕ : 1.2 + 0.9
Output @ 50° C Δ T: n/a
Elec. element if specified: 125
Pipe Centres: n/a

All dimensions in inches

Manufactured from 1.4301/X5CrNi18-10 stainless steel

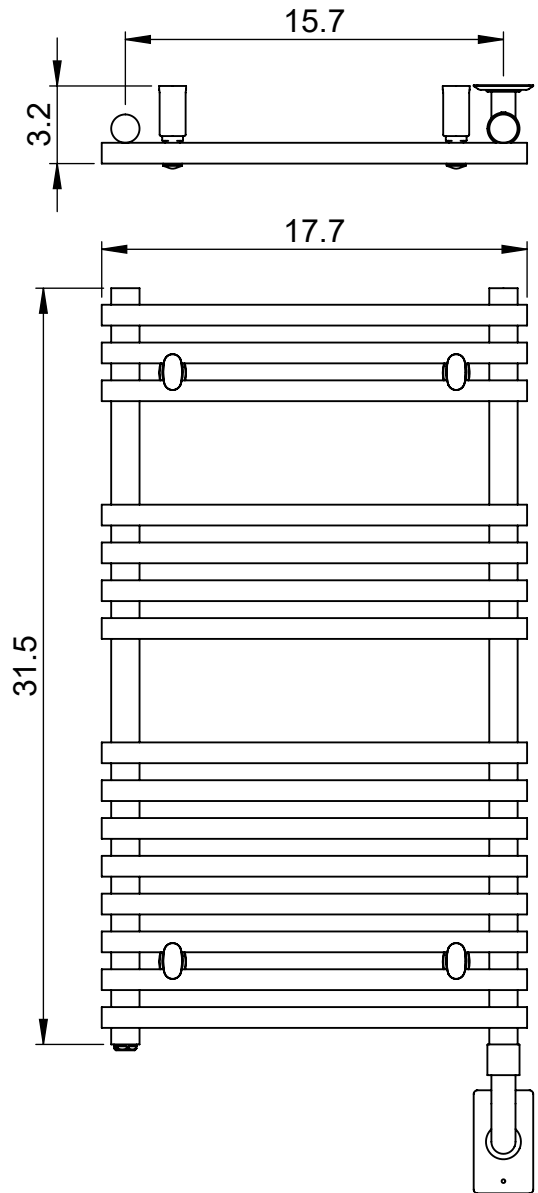
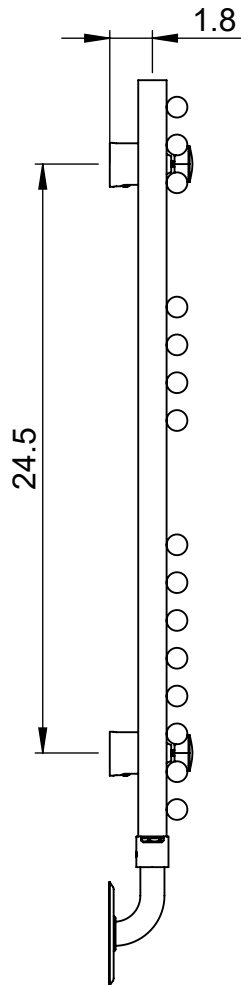
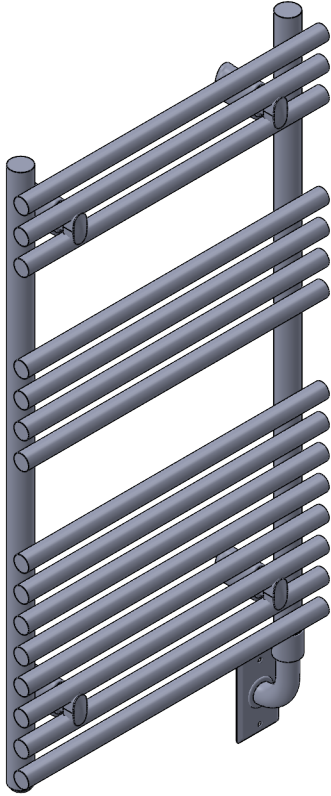

inches	mm
31.5	800
17.7	450
3.2	80
24.5	623
15.7	400
1.8	45

Vogue UK Ltd. reserve the right to alter specifications without prior notice.
ALL MEASUREMENTS ARE NOMINAL DIMENSIONS ONLY, AND ARE NOT BINDING.

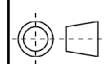

SCALE 1:8

VOGUE
TOWEL DRYERS

175 Memorial Drive Unit C
Shrewsbury MA 01545 USA
Tel: 508 887 8771 Fax: 508 887 8774
e-mail: info@vogueuk.com www.vogueuk.com