

# IN002A

## 5.5x19.7

Height: 5.5

Width: 19.7

Depth: 3.5

Weight HO: 20.9lbs (9.5kg)

EO: 38.6lbs (17.5kg)

Tube  $\phi$ : 1.6sq

Output @ 50° C  $\Delta$  T: n/a

Elec. element if specified: 100

End to End Connections: n/a

All dimensions in inches

Manufactured from 1.4301/X5CrNi18-10 stainless steel

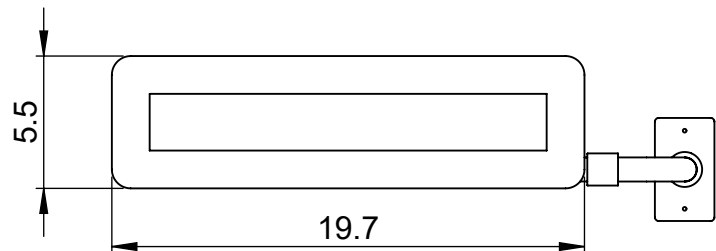
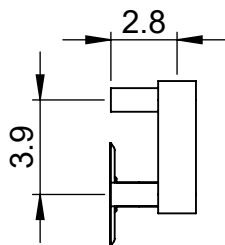
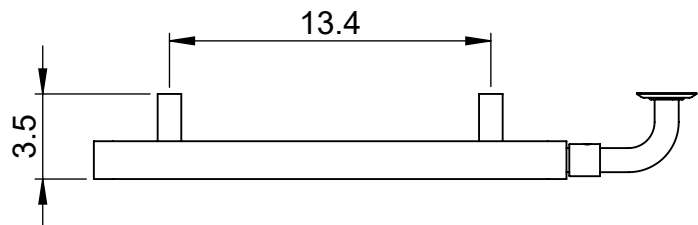
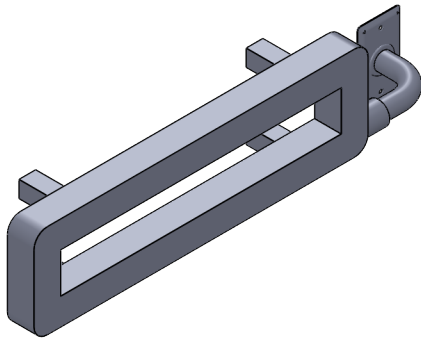

inches	mm
5.5	140
19.7	500
3.5	90
3.9	100
13.4	340
2.8	70

Vogue UK Ltd. reserve the right to alter specifications without prior notice.  
ALL MEASUREMENTS ARE NOMINAL DIMENSIONS ONLY, AND ARE NOT BINDING.

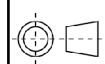

**SCALE 1:8**

# VOGUE

TOWEL DRYERS

175 Memorial Drive Unit C  
Shrewsbury MA 01545 USA  
Tel: 508 887 8771 Fax: 508 887 8774  
e-mail: info@vogueuk.com www.vogueuk.com