

EN011C

59.1x19.7

Height: 59.1
 Width: 19.7
 Depth: 3.9
 Weight HO: lbs (kg)
 EO: lbs (kg)

Tube ϕ : 1.2sq + 0.8sq
 Output @ 50° C Δ T: n/a
 Elec. element if specified: 400
 Pipe Centres: 17.3

All dimensions in inches

Manufactured from 1.4301/X5CrNi18-10 stainless steel

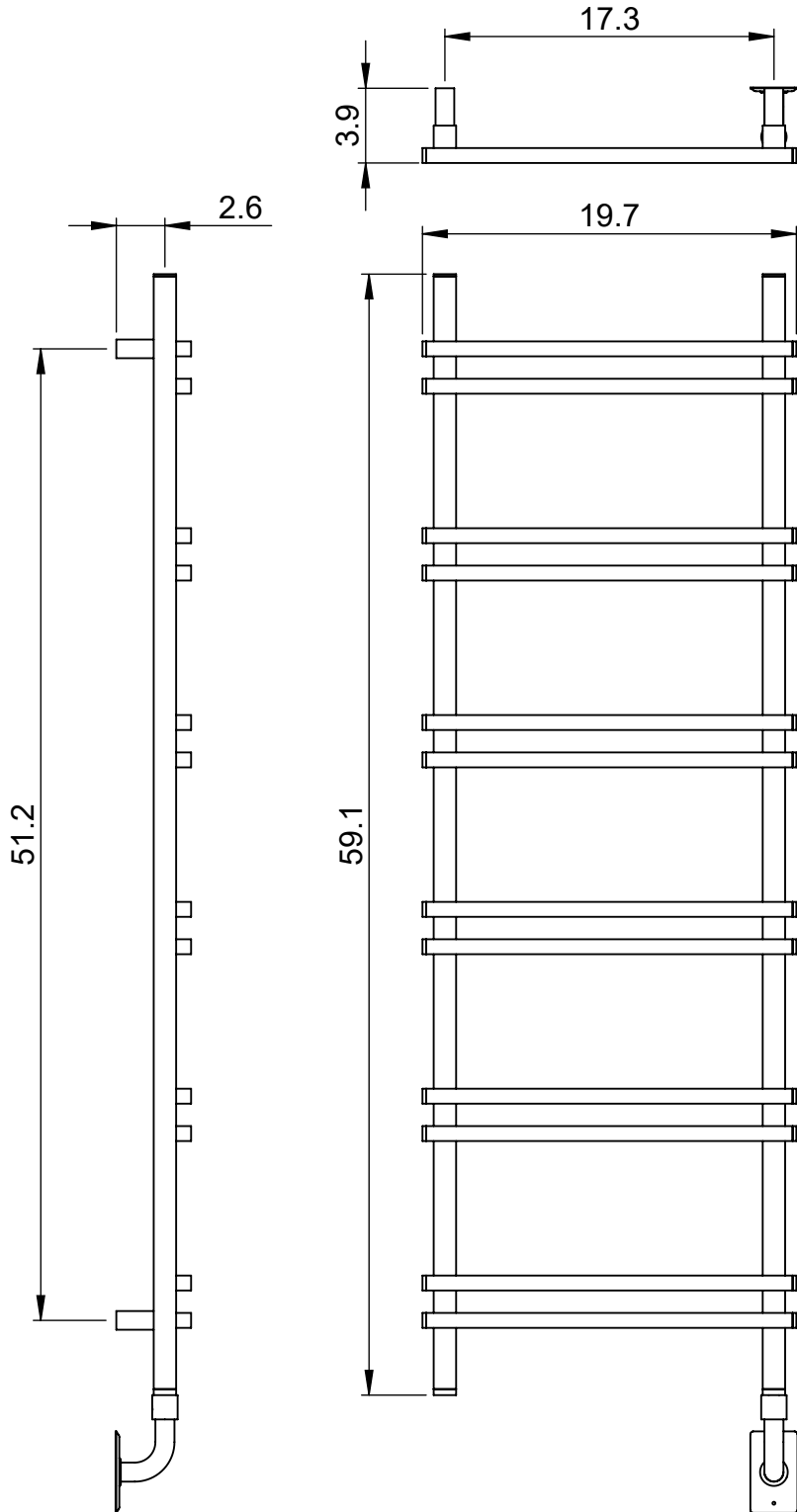
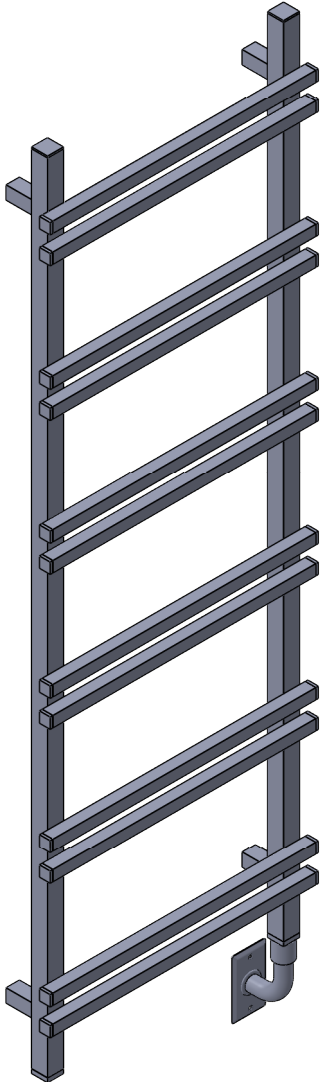

inches	mm
59.1	1500
19.7	500
3.9	100
51.2	1300
17.3	440
2.6	65

Vogue UK Ltd. reserve the right to alter specifications without prior notice.
 ALL MEASUREMENTS ARE NOMINAL DIMENSIONS ONLY, AND ARE NOT BINDING.



SCALE 1:10

VOGUE

TOWEL DRYERS

175 Memorial Drive Unit C
 Shrewsbury MA 01545 USA
 Tel: 508 887 8771 Fax: 508 887 8774
 e-mail: info@vogueuk.com www.vogueuk.com