

EN011A

29.5x19.7

Height: 29.5
 Width: 19.7
 Depth: 3.9
 Weight HO: lbs (kg)
 EO: lbs (kg)

Tube ϕ : 1.2sq + 0.8sq
 Output @ 50° C Δ T: 277
 Elec. element if specified: n/a
 Pipe Centres: 17.3

All dimensions in inches

Manufactured from 1.4301/X5CrNi18-10 stainless steel

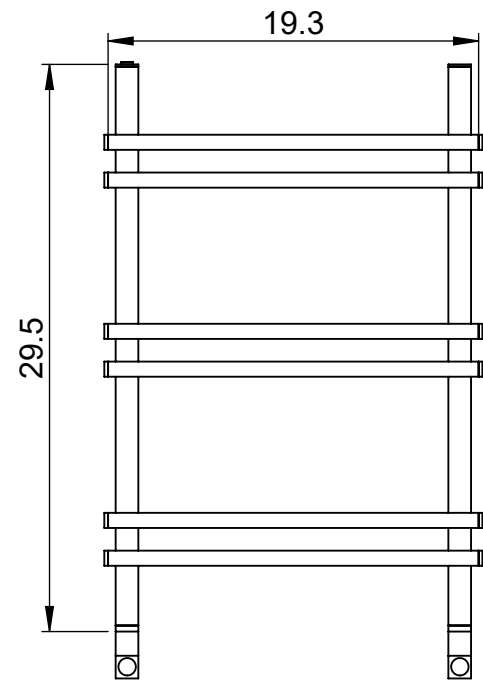
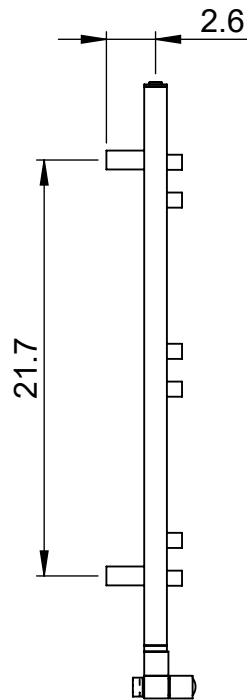
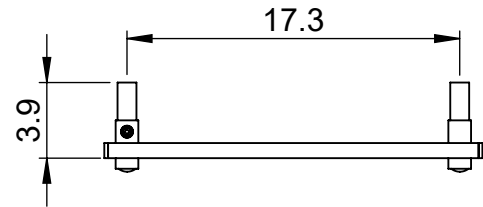
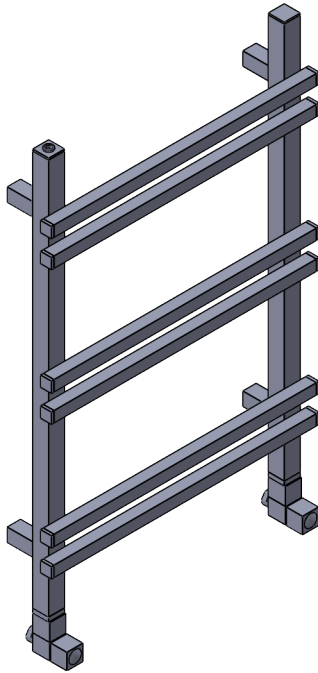

inches	mm
29.5	750
19.3	490
3.9	100
21.7	550
17.3	440
2.6	65

Vogue UK Ltd. reserve the right to alter specifications without prior notice.
 ALL MEASUREMENTS ARE NOMINAL DIMENSIONS ONLY, AND ARE NOT BINDING.



SCALE 1:10

VOGUE

UK
 TOWEL DRYERS

175 Memorial Drive Unit C
 Shrewsbury MA 01545 USA
 Tel: 508 887 8771 Fax: 508 887 8774
 e-mail: info@vogueuk.com www.vogueuk.com