

CN021 29.5x17.7

Height: 29.5
 Width: 17.7
 Depth: 3.7
 Weight HO: 16.5lbs (7.5kg)
 EO: 25.4lbs (11.5kg)

Tube ϕ : 1 + 0.9
 Output @ 50° C Δ T: n/a
 Elec. element if specified: 75
 Pipe Centres: 15.7

All dimensions in inches

Manufactured from ISO/CEN CuZn36As (BS CZ126) brass tube

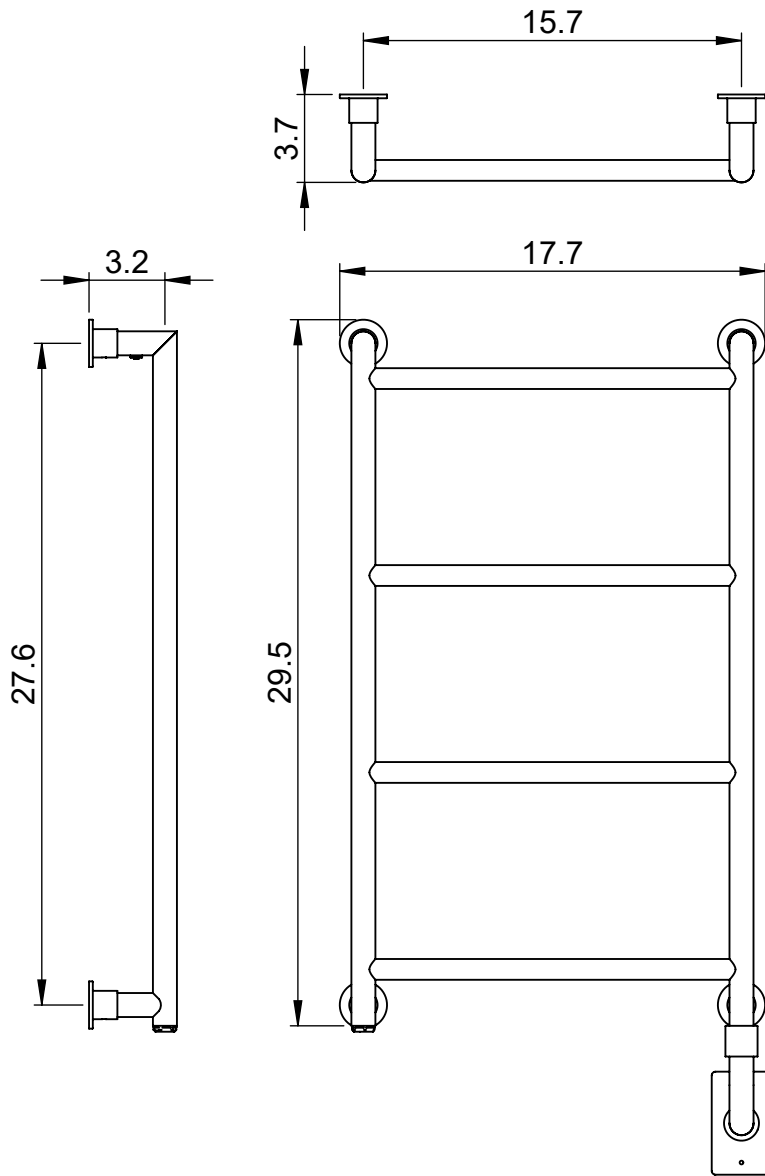
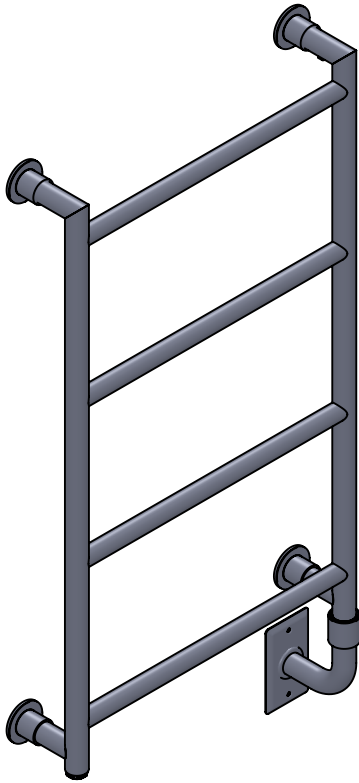

inches	mm
29.5	750
17.7	450
3.7	93
27.6	700
15.7	400
3.2	80

Vogue UK Ltd. reserve the right to alter specifications without prior notice.
 ALL MEASUREMENTS ARE NOMINAL DIMENSIONS ONLY, AND ARE NOT BINDING.

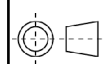

SCALE 1:8

VOGUE
 TOWEL DRYERS

175 Memorial Drive Unit C
 Shrewsbury MA 01545 USA
 Tel: 508 887 8771 Fax: 508 887 8774
 e-mail: info@vogueuk.com www.vogueuk.com