



## UNDERCOUNTER WINE CELLARS

15"W. VUWC515GSS and 24"W. VUWC524GSS

### FEATURES

- Storage Capacity
  - 15"W. model:  
Volume of 2.9 cu. ft. holds up to 28 wine bottles (750ml)
  - 24"W. model:  
Volume of 5.2 cu. ft. holds up to 49 wine bottles (750ml)
- Full-depth lower interior maximizes storage options
- Variable speed compressor delivers maximum energy efficiency, faster temperature response, and quieter operation
- Convection cooling system provides a quick cool down and consistent temperature
- Temperature range: 33°F – 70°F
- Stainless steel interior
- Stainless steel cabinet, toe kick, and accents
- Easy adjusting interior with 19 adjustable positions
- Seven removable, full-extension wine racks
- Wine racks accommodate a variety of bottle shapes and sizes and can be configured to store champagne and magnum bottles
- Digital touch pad control with blue LED display
- Adjustable bright white or blue LED lighting
- Soft close door with articulating hinge
- Field reversible door is shipped right-hand hinged
- Built-in or freestanding
- Four adjustable leveling legs



### MODEL NUMBERS

- VUWC515GSS – 15"W. Undercounter Wine Cellar
- VUWC524GSS – 24"W. Undercounter Wine Cellar

### DESIGN OPTIONS

- Product ships as right hinge; field reversible

### COLOR FINISHES

- Available in Stainless Steel (SS)

### WARRANTY

- 2-year full covers complete unit
- 6-year full – sealed refrigeration system
- 90-day full – cosmetic parts such as glass, painted items, and decorative items
- 12-year limited – sealed refrigeration system

### UNDERCOUNTER WINE CELLARS

MODEL	VUWC515GSS	VUWC524GSS
Amps: Running	1.2	
Capacity: Bottle (12 oz)	N/A	
Capacity: Can (12 oz)	N/A	
Capacity Volume (cu ft)	2.9	5.2
Capacity: Wine Bottle (750 ml)	28	49
Dimensions: Product Depth	22 15/16" (583 mm)	
Dimensions: Product Height (Min.)	33 11/16" (855 mm)	
Dimensions: Product Width	14 15/16" (379 mm)	23 5/8" (600 mm)
Energy Consumption: Avg. Per Year	285 kWh	305 kWh
ENERGY STAR (glass door)	No	
Refrigerant Type:	R600a	
Sabbath (Star K Certified)	Yes	
Temperature Range	33°F – 70°F	
Voltage	115/60	
Weight	105 lb.	163 lb.

Please do not prepare installation from brochure data only.  
See installation instructions for important clearance/installation information.



# UNDERCOUNTER WINE CELLARS

15"W. VUWC515GSS and 24"W. VUWC524GSS

## FRONT

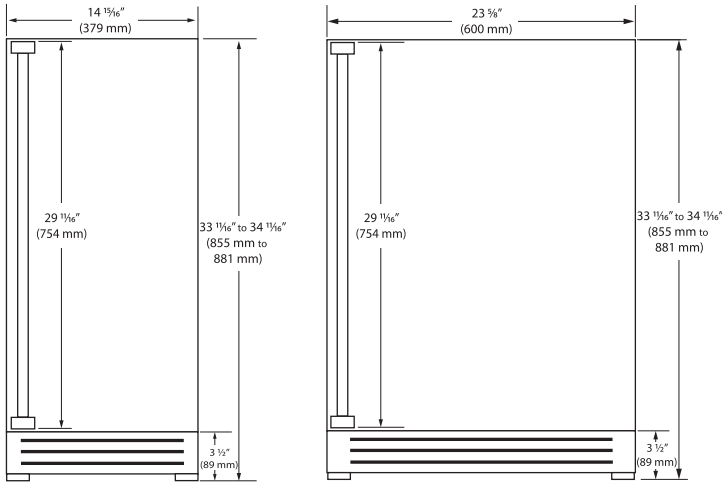

## TOP

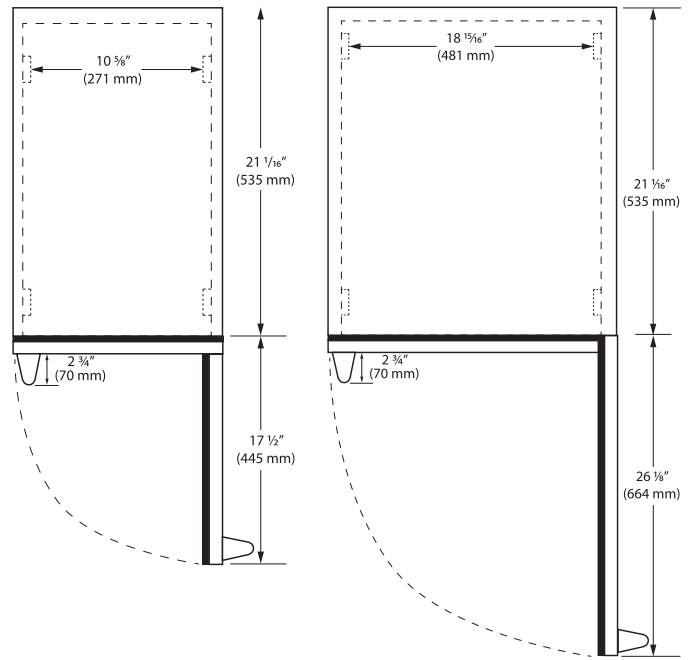

## SIDE

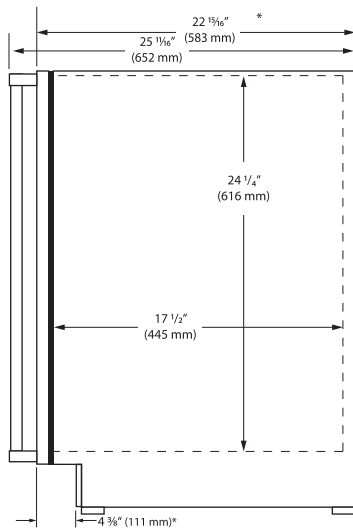

## CUTOUT

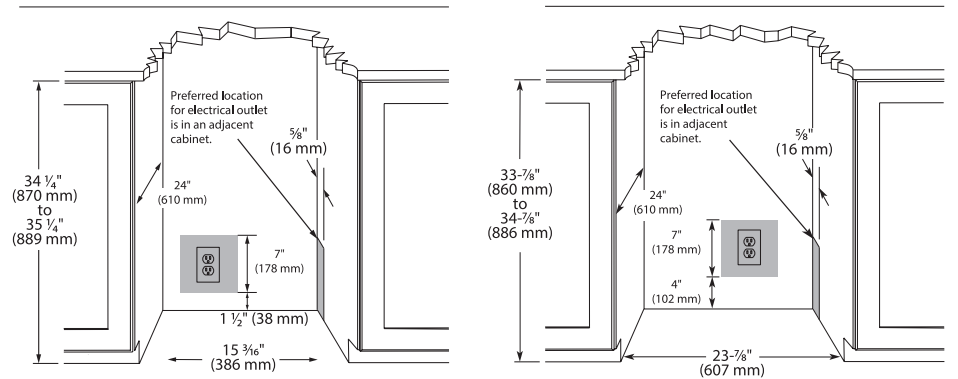

## REAR

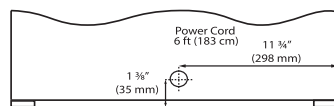
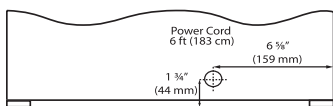

VIKING RANGE, LLC 111 FRONT STREET GREENWOOD, MISSISSIPPI 38930 USA

For detailed product information, model numbers, or to request a quote call 1-888-845-4641 or visit [vikingrange.com](http://vikingrange.com)  
 © 2019 Viking Range, LLC All rights reserved. Specifications subject to change without notice.