

Use/Install GUIDE



Under-counter
Micro Green & Herb Cabinet
GCV12

TABLE OF CONTENTS



TABLE OF CONTENTS

FEATURES AND SPECIFICATIONS	3
UNPACKING AND INSPECTION	4
SAFETY PRECAUTIONS	5-6
INSTALLATION & STARTUP	6-11
PROGRAMMING	12-13
SETTING UP YOUR GROWING CYCLES	14
FUNCTIONS OF THE ZONE SCREEN	14
FUNCTIONS OF THE MAIN RESERVOIR SCREEN	14
PLANTING & GROWING	15
GROWING GUIDE	16
GROWING DO'S AND DON'TS	17
CLEANING AND MAINTENANCE	18-19
PERIODIC MAINTENANCE PROCEDURES	20
REPLACING THE LIGHTS	21
SANITATION AND FOOD SAFETY	22
FREQUENTLY ASKED QUESTIONS & TROUBLESHOOTING	23
MICRO GREEN PROBLEMS	24
RESOURCES	25-26
WIRING & PLUMBING DIAGRAMS	27-28
SERVICE INFORMATION	29
WARRANTY	30

FEATURES AND SPECIFICATIONS

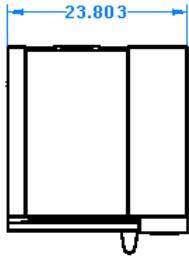

Your Viking Range, LLC Micro Green & Herb Cabinet provides a self-contained environment that is ideal for growing herbs, micro greens and even edible flowers. The lights produce the proper spectrum and an irrigation system delivers water and nutrients to the plants. The automated system provides everything the plants need to grow year round and right in the kitchen. It is preprogrammed for the growing needs for common herbs and micro greens. You can customize the growing conditions for other plants as needed.

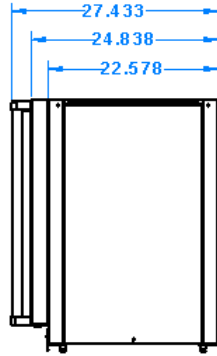
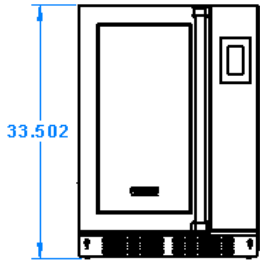

GCV12LSS

Model Number	Number of Growing Zones	Capacity 10" x 20" Trays	Overall Dimensions			Door Hinge Location	Adjustable Leg Height	Shipping Weight
			Height	Depth	Width			
GCV12RSS	2	2	33-1/2 (851 mm)	24-7/8" (632 mm)	23-7/8 (607 mm)	Right	1-1/8 (28.6 mm)	150 (68kg)
GCV12LSS	2	2	33-1/2 (851 mm)	24-7/8" (632 mm)	23-7/8 (607 mm)	Left	1-1/8 (28.6 mm)	150 (68kg)

CONSTRUCTION...Welded & riveted double wall, non-insulated cabinet construction.

CABINET MATERIAL... 430 series stainless steel exterior; 301 series interior with reflective finish

BASE FRAME... 18 gauge stainless steel full depth bolsters.

LEGS...2.5" Adjustable leveling bolts

DOORS...Double panel tempered glass door with integrated gasket. Full length door handle. GCV12RSS hinged on right; GCV12LSS hinged on left.

GROWING DRAWERS... Removable growing drawers. Stainless steel construction with drainage holes in rear for ebb and flow irrigation. Each drawer will accommodate one standard 10" x 20" flat with 5" or 7" greenhouse dome for sprouting. Includes one set of growing trays and 5"

Level	Growing Space
1 (top shelf)	10.125"
2	10.125"

domes.

CONTROLS...Touchscreen digital controls. Automated system provides correct measures of water, nutrients, relative humidity, lighting on optimum cycle for plant growth and nutrient data. Pre-programmed default settings for most growing needs; programmable for other growing situations. Lock-out access code.

ENVIRONMENT... Digital controls for automatic light, watering schedule and humidity levels for growing. Temperature based on ambient room temperature.

WATERING SYSTEM... Automatic filtered pump/aerator irrigation system delivers water and nutrients from the reservoir to the plants. Programmable watering cycle. Auto-fill reservoir. 3/8" NPT fill connection: 3/8" NPT drain connection. pH and

Default Programs:
 Watering Cycle: Once every 4 days
 Watering Time: 5 Minutes
 Daylength: 18 Hours (lights on each day)

TDS (total dissolved solids) sensors.

GROWING LIGHTS... Equipped with 18" T5 high output fluorescent light fixtures. Each fixture includes an integrated electronic ballast, 6400°K lamp with a nanotech reflector for maximum reflection. Lights imitate the sun's rays for optimum growing. Removable opaque polycarbonate shields. Fully programmable light cycles.

ELECTRICAL CHARACTERISTICS...
 GCV12: operates on 120 volts, 1.6 amps, 60 cycle, single phase. Junction box provided for hardwiring of unit or a power cord kit may be purchased and installed in order to plug unit into existing outlet.

ACCESSORIES/OPTIONS...

- Starter kit: includes growing trays, mats, domes, sifter, pH & TDS calibration solutions, hydrogen peroxide, 20 gallon plastic tub, measuring syringe
- Power cord kit: includes one 6' power cord with a NEMA 5-15P molded plug cap; cord grip; wire nuts.

UNPACKING AND INSPECTION



This appliance should be thoroughly cleaned prior to use. See the **CLEANING INSTRUCTIONS** in this manual.

NOTE: DO NOT discard the carton or other packing materials until you have inspected the appliance for hidden damage and checked it for proper operation.

Refer to **SHIPPING DAMAGE CLAIM PROCEDURE** on

1. Remove the cabinet from shipping carton, ensuring that all packing materials and protective plastic has been removed from the unit.
2. Inspect all components for completeness and condition.
3. If any freight damage is present, a freight claim must be filed immediately with the shipping company.
4. Freight damage is not covered under warranty.
5. Check to insure all components are included: cabinet, instruction packet and additional accessories.
6. Read operation instructions completely.
7. Appliance should be thoroughly cleaned before use. See **CLEANING INSTRUCTIONS** in this manual (pages 17-18).

CAUTION: Health and safety regulations vary by jurisdiction. Prior to installation, operator must be aware and must adhere to all local and state codes, including proper installation, plumbing and electrical hook up, as well as any health certificates that may be required when growing food in your establishment. Viking Range, LLC assumes no responsibility for improper installation or use of this product or failure to adhere to local regulations.

NOTE: This unit is to be installed with adequate backflow protection to comply with all applicable federal, state and local codes.

FREIGHT DAMAGE PROCEDURE

NOTE: For your protection, please note that equipment in this shipment was carefully inspected and packaged by skilled personnel before leaving the factory. Upon acceptance of this shipment, the transportation company assumes full responsibility for its safe delivery.

IF SHIPMENT ARRIVES DAMAGED:

1. **VISIBLE LOSS OR DAMAGE:** Be certain that any visible loss or damage is noted on the freight bill or express receipt, and that the note of loss or damage is signed by the delivery person.
2. **FILE CLAIM FOR DAMAGE IMMEDIATELY:** Regardless of the extent of damage. Contact your dealer immediately.
3. **CONCEALED DAMAGE:** If damage is unnoticed until the merchandise is unpacked, notify the transportation company or carrier immediately, and then file a "CONCEALED DAMAGE" claim with them. This should be done within fifteen (15) days from the date the delivery was made to you. Be sure to retain the container for inspection.

Viking Range, LLC cannot assume liability for damage or loss incurred in transit. Freight damage is not covered under warranty. We will, however, at your request, supply you with the necessary documents to support your claim.

IMPORTANT SAFETY INSTRUCTIONS

For your safety and the proper operation of this appliance, please follow these safety guidelines. This manual should remain with the appliance so that new owners and users learn about the product and relevant safety precautions. Carefully read through this manual before installing and using the herb cabinet

- This appliance is designed to be operated by adults.
- The water from your unit is not for drinking.
- Keep your seeds, nutrients and growing mediums in a safe, dry storage area.

When using electrical appliances basic safety precautions should be followed, including the following:

1. Be familiar with the appliance use, limitations and associated restrictions. Operating instructions must be read and understood by all persons using or installing this appliance.
2. This appliance must be grounded. Connect only to properly grounded outlet or circuit.
3. Use this appliance only for its intended purpose as described in the manual.
4. Cleanliness of this appliance and its accessories is essential to good sanitation.
5. DO NOT submerge this appliance in water. This appliance is not jet stream approved. DO NOT direct water jet or steam jet at this appliance, or at any control panel or wiring. DO NOT splash or pour water on, in or over any controls, control panel or wiring. DO NOT use corrosive chemicals or vapors in this appliance.
6. DO NOT store this appliance outdoors. DO NOT use this product near water – for example, near a kitchen sink, in a wet basement, or near a swimming pool, and similar areas.
7. DO NOT operate this appliance if it has a damaged cord or plug, if it is not working properly, or if it has been damaged or dropped. Do not immerse cord or plug in water, keep cord away from heated surfaces, and do not let cord hang over edge of table or counter.
8. DO NOT cover or block any openings on the appliance.
9. Only qualified service personnel should service this appliance.

Safety Precautions During Operation

1. Contaminated items and/or garbage must not be present in the appliance.
2. Keep the door closed when not working with the cabinet.
3. Do not remove the growing drawers when the appliance is watering. Refer to instructions for controlling the watering and lighting schedules.
4. Do not sit or stand on the open door or growing drawers. Doing so will ruin the drawers and slides.
5. Turn off the power and shut off the water supply when the appliance is not in use. The pH sensor must be placed back into its case with storage solution when not in use.
6. Use genuine OEM parts when servicing and repairing the appliance. Any attempts to repair the cabinet without an authorized professional can be dangerous and void your warranty.
7. Take care when removing the grow drawers as they may weigh as much as 15 pounds when fully loaded with plants, soil and water.

CAUTION: Purchase supplies and seeds from reputable suppliers and follow instructions for proper safety and growing. Viking Range, LLC assumes no liability for conditions resulting from improper growing, maintenance and safety. Follow all safe food handling practices when growing and harvesting.

SAFETY PRECAUTIONS



WARNING: ELECTRIC SHOCK HAZARD

All service requiring access to non-insulated components must be performed by qualified service personnel. Failure to heed this warning may result in severe electric shock.



CAUTION: ELECTRIC SHOCK HAZARD

Disconnect this appliance from electrical power before performing any maintenance or service.

SAFETY PRECAUTIONS



WARNING:
Risk of personal injury

Installation procedures must be performed by a qualified technician with full knowledge of all applicable electrical and plumbing codes. Failure could result in personal injury and property damage.



IMPORTANT:
Power cord is 6' long

If necessary, contact a licensed electrician to install an appropriate 15 amp electrical circuit with correct NEMA receptacle. Ensure that the plug is accessible after installation. **DO NOT** use an extension cord.



CAUTION: Electrical Shock Hazard

The ground prong of the power cord is part of a system designed to protect you from electric shock in the event of internal damage.

DO NOT cut off the large round ground prong or twist a blade to fit an existing receptacle.



IMPORTANT: FILTERED WATER REQUIRED

Due to varying water quality in different municipalities, make sure that your facility water is filtered of sediment and chemicals before hooking up the fill lines. Sediment from hard and/or softened water may eventually clog up the pumps and filters.



IMPORTANT:
Not under warranty

Damage to unit due to being connected to the wrong voltage or phase is **NOT** covered by warranty.

GROUNDING INSTRUCTIONS

This appliance is equipped with a cord having a grounding wire with a grounding plug which must be hard wired or plugged into an outlet that is properly installed and grounded. In the event of an electrical short circuit, grounding reduces the risk of electric shock by providing an escape wire for the electric current.

WARNING—Improper use of the grounding can result in a risk of electric shock. Consult a qualified electrician or service agent if the grounding instructions are not completely understood, or if doubt exists as to whether the appliance is properly grounded.

LOCATION AND INSTALLATION

- Place the cabinet on level ground so that the inside water flows evenly. Adjust the leveling legs so that they are on the floor. If your floor is not level, adjust the legs so that the unit is level. **NOTE:** Unit must be level in order to function properly.
- See **CUTOUT DIMENSIONS ON NEXT PAGE**
- Leave at least 19 inches (483 mm) at the front of the cabinet, so there is ample space for opening the doors and pulling the drawers out.
- Connect city water supply and city drain to the 3/8" NPT female fittings at the back of the unit. Access to the connections will be at the back of the cabinet. **NOTE:** This unit is to be installed with adequate backflow protection to comply with all applicable federal, state and local codes.
- City water connection *must not be further than 10 feet from the cabinet and no higher than 6 feet from the connections. A minimum of 35 PSI is required to feed the cabinet.*
- Install the lights and diffuser panels (instructions on page 20)
- The 120V electrical outlet should be within 6 feet of the cabinet. Do not use an extension cord. Connect to a properly grounded outlet according the electrical specifications for the cabinet. See page 3 for specifications.

Pipes that have not been in regular use should be cleaned and flushed with running water prior to connecting to cabinet



Make sure the water inlet hose and drain hose are not twisted, crushed, entangled or leaking. Do not use connection hoses that have been used previously for other appliances.



If the unit is built in to a wall or structure, make sure that it can be easily moved for access to the back and side panels for service and maintenance.

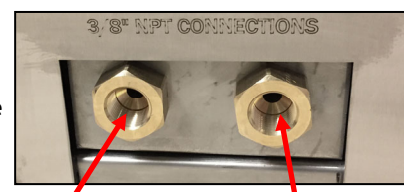

City **DRAIN** connection:
3/8" NPT female fitting

City **FILL** connection:
3/8" NPT female fitting

CUTOUT DIMENSIONS

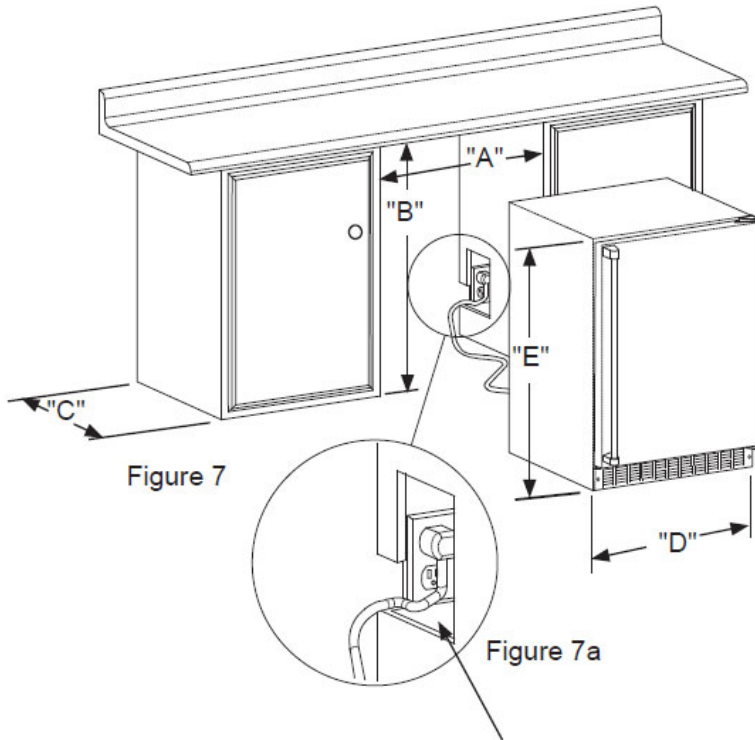

A	24" (61.0 cm)
B	**34" to 35" (86.4 to 88.9 cm)
C	*
D	23-7/8" (60.7 cm)

* Depth dimension of rough-in opening may vary depending on each individual installation. To recess entire door "F" dimension plus 1" (2.5 cm) for thickness of power cord plug is required.

** Minimum rough-in opening required is to be larger than the adjusted height of the cabinet.

If necessary to gain clearance inside the rough-in opening a hole can be cut through the adjacent cabinet and the power cord routed through this hole to a power outlet. Another way to increase the available opening depth is to recess the power outlet into the rear wall to gain the thickness of the power cord plug. Not all recessed outlet boxes will work for this application.

START-UP

Note: the cabinet must be plugged in or wired and plumbed by a professional technician to all applicable local and state plumbing and electrical codes. When you power up the unit in, it will turn on and you will see the startup screen (A). The unit runs diagnostics and start-up functions while this screen is visible. You do not need to do anything while the startup screen is showing. The unit will automatically go to the HOME screen following the start up screen. To unlock the screen, press any button and a number pad will appear. Enter "1551" then "✓". Note: when the cabinet sits for long periods of time or it is turned off and then on again, it will automatically revert to locked mode. You will have to use the unlock code any time this happens. Follow these steps to set up your Herb cabinet for the first time:

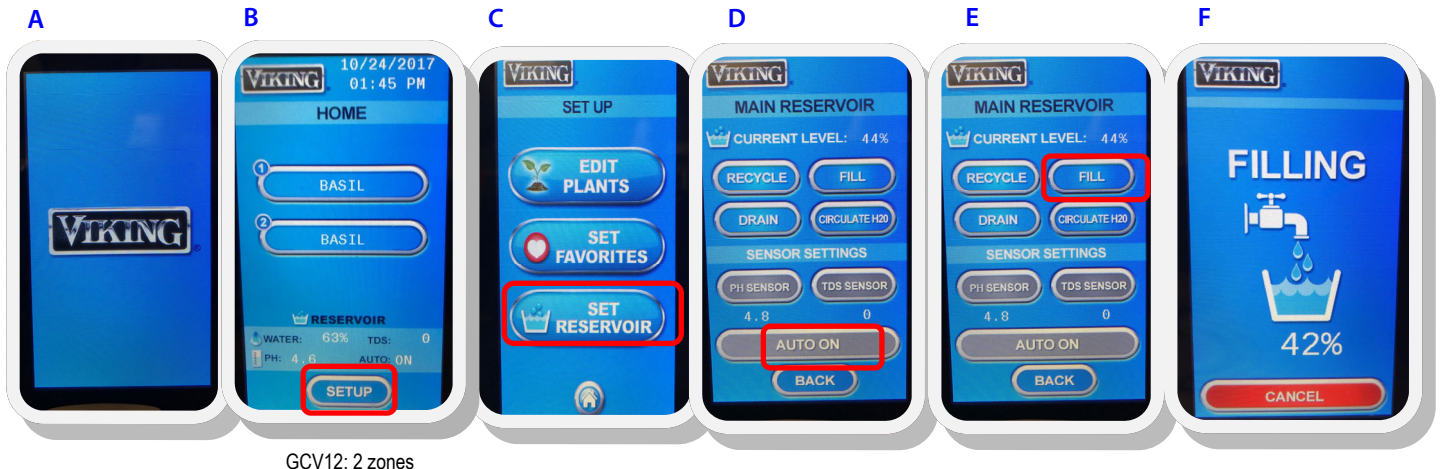

GCV12: 2 zones

FILL THE WATER RESERVOIR USING CITY WATER

Ensure water lines are hooked up first (see page 6). Ensure the reservoir is free of dirt and foreign objects before filling.

1. Remove the lower grow drawer to access the water reservoir
2. From the home screen (B), press SETUP, SET RESERVOIR (C), AUTO ON (D) to switch to city water mode*
3. Press FILL (E) and check to make sure the water is filling into the reservoir. The screen will display FILLING (F).
4. Once full, the cabinet's onboard computer will maintain a constant water level

*For manual filling, make sure to press AUTO OFF, then fill manually to the top of the float sensor (about 3.25" deep). Water level must be monitored and replenished if it gets low.

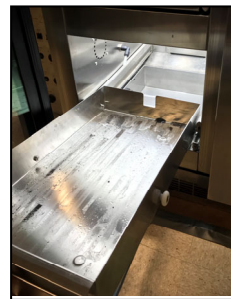



Fig. 1
Access the water reservoir



Fig. 2 Float switch/sensor; right side of reservoir; shuts off water once filled to proper level

SET UP THE pH DOSER (pH down solution required)

 Note: Auto dosing requires that the irrigation pump be primed first. See page 10 for instructions.

1. Remove the lower grow drawer to access the dry box (Fig. 3)
2. Place a pH dosing bottle in the dry box. Any clean bottle will do as long as it is not taller than the dry box. Drill a hole into the cap to insert the dosing line. If the cap is the same size as your pH down solution bottle, place the cap from the dosing bottle onto the pH down bottle. If they are not the same size, fill the pH dosing bottle with pH down solution. Place the bottle into the dry box.
3. From the home screen (B), press SETUP, SET RESERVOIR (C), then
4. Press PH SENSOR (F), then
5. Set AUTO DOSE to ON (G) and then
6. Press DONE (G)

The onboard computer will check every hour and will run the dosing pump as needed to maintain the PH level. Default PH is 5.5, but can be changed on the SET RESERVOIR screen. Most plants need a pH level of 5 to 7. See growing tips on page 16 regarding low pH.

Note: Calibration does not need to be done on initial set-up.

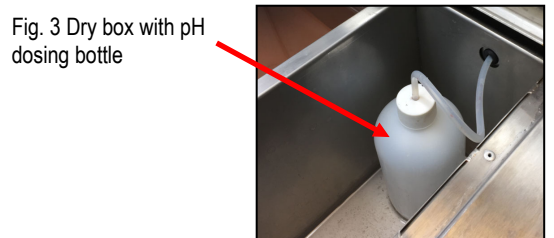
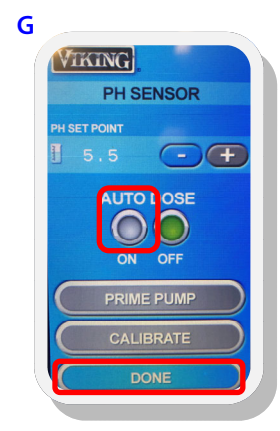
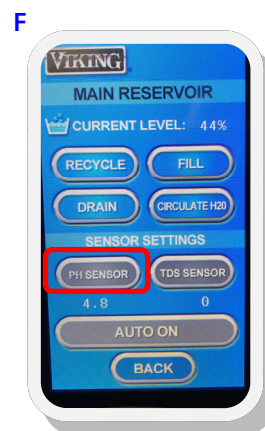

Fig. 3 Dry box with pH dosing bottle



CALIBRATE THE pH SENSOR



1. Remove the lower grow drawer to access the reservoir (Fig.1)
2. Locate the pH sensor probe on the right side of the reservoir (Fig.2)
3. Fill one cup of water, one cup of pH buffer #4 (Fig. 3) and one cup of pH buffer #7 (Fig. 4)
4. Remove cap from the sensor and gently wash the pH probe in the water and dry on a clean cloth.

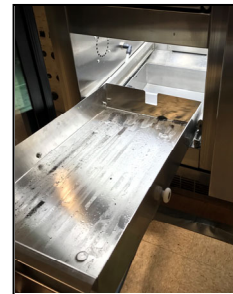

Fig. 1 Access the water reservoir; the sensor will be on the left side.

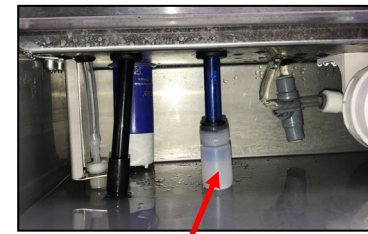
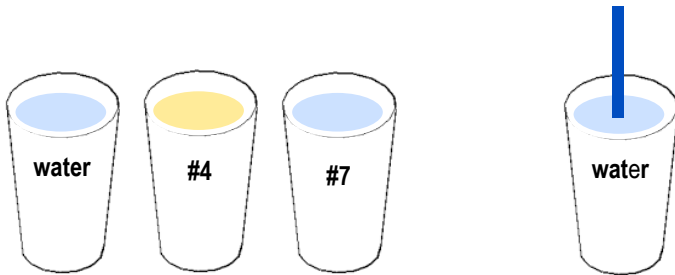

Fig. 2 Blue PH sensor (shown with cap on)

5. Gently swish the probe in the pH buffer #4. Continue to swish the probe and follow instructions in step 6.



6. Enter the pH calibration screen press SETUP (A), SET RESERVOIR (B), PH SENSOR(C), then CALIBRATE (D) and follow the instructions on the screen.

Calibration will take about three minutes to complete.

7. Wash the pH sensor in the cup of water and dry on a clean cloth. Repeat steps 5 and 6 for pH buffer #7 solution



8. Press DONE when calibration is complete



IMPORTANT: Safely store the pH sensor cap and use it to stop the sensor from drying out when the water reservoir is empty. Do not let the pH sensor dry out. Fill cap with pH #4 calibration solution before placing it on probe to store the sensor. Failure to follow this procedure will ruin the sensor and void the warranty.

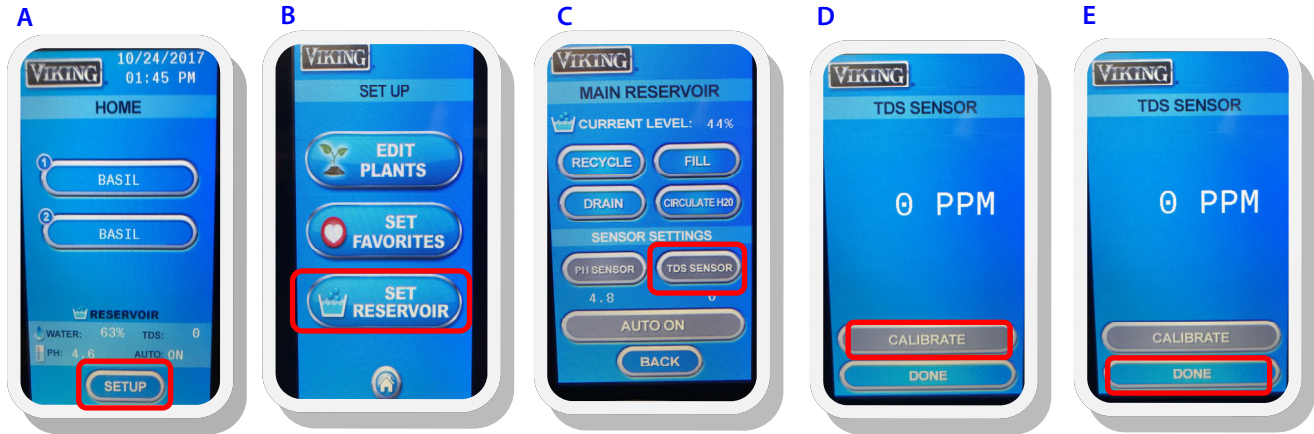

Fig. 3 PH buffer #4



Fig. 4 PH buffer #7

CALIBRATE THE TOTAL DISSOLVED SOLIDS (TDS) SENSOR (EC 1000 PPM solution required)



1. Remove the lower grow drawer to access the reservoir (Fig.1)
2. Locate the TDS sensor probe on the right side of the reservoir (Fig.2)

3. Fill one cup of water, and one EC 1000 PPM solution

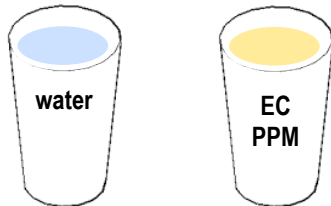

Fig. 1
Access the water reservoir

4. Gently wash the TDS probe in the water and dry on a cloth



5. Gently swish the probe in EC PPM solution and, while swishing the probe, enter the calibration screen.

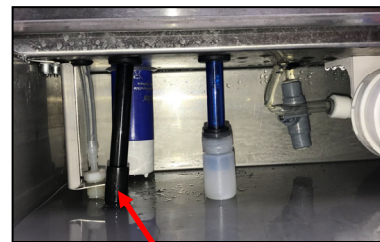

Fig. 2
TDS sensor (black)

6. To enter the TDS calibration screen press SETUP (A), SET RESERVOIR (B), TDS SENSOR(C), then CALIBRATE (D) and follow the instructions on the screen. Continue to swish the probe in the solution for three minutes.

Calibration will take about three minutes to complete.

Press DONE (E) when complete.

PRIMING THE IRRIGATION PUMP

- Access reservoir (Fig. 1)
 1. If present, remove the bottom grow tray
 2. Slide out drawer to access the reservoir

- Fill reservoir
 1. Make sure that the unit has been connected to the water and power according to local codes
 2. From the HOME screen, press SET UP, SET RESERVOIR, AUTO ON, FILL

Fig. 1

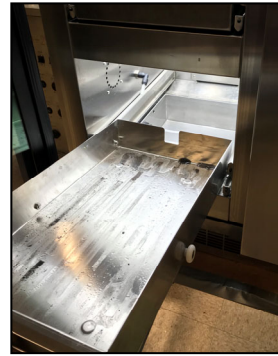

Fig. 2

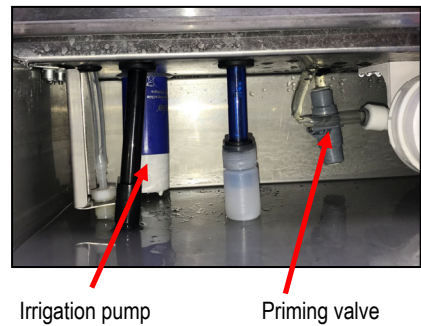

Fig. 3
Priming valve in OPEN position

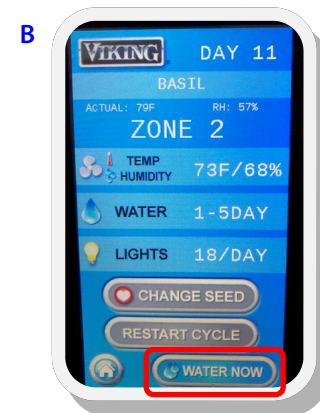
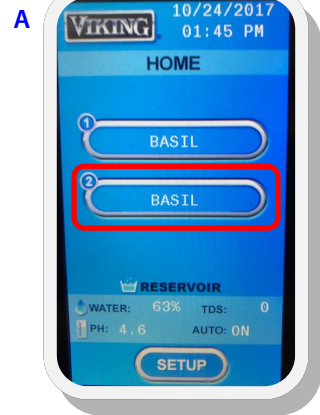

Fig. 4
Priming valve in CLOSED position

- Priming
 1. Access the priming valve near the irrigation pump. It should be in the OPEN position and water should be flowing downwards into the reservoir
 2. From the HOME screen, choose ZONE 2 (A). This will be the growing zone that is directly above the pump. Press WATER NOW (B).
 3. Open (1/4 clockwise turn) and wait for steady stream of water to come out of the priming valve (Fig 3); once you have a steady stream of water, close the valve (Fig 4).
 4. Water should now be flowing steadily from the irrigation nozzle in the zone selected in step 2 (Fig. 5). Press WATER NOW (B) to turn off the watering cycle for that zone. Leave the priming valve in the CLOSED position.

Your pump is now primed.

Fig. 5 Zone irrigation nozzle



SETTING UP YOUR GROWING CYCLES

Note: The cabinet must be plugged in or hard wired and plumbed by a professional technician. Follow these steps to set up your cabinet for the first time.



SET UP THE DATE AND TIME

On the home screen, press the date/time in the upper right hand corner. This will take you to the TIME AND DATE SCREEN (A).

Using the UP and DOWN arrows, set the date and time.

Press DONE when you are finished.

SELECT SEEDS FROM THE SEED LIST

The cabinet comes with pre-set cycles for growing a variety of plants. It can also be programmed to set up the zones for special seeds or changing the lighting and watering cycles for each plant. On the HOME screen (B), select the zone for the seed you would like to program: GCV12 (2 zones). On the zone screen (C), press CHANGE SEED and you will be taken to the FAVORITES screen(D).

An alphabetical list of preprogrammed seeds will appear. Scroll through the list to find the seed you want, using the NEXT button to get to each screen (there are 5 screens, with a few spaces left empty at the end for custom programming of new items). NONE is the first item and can be used for designating shelves that might not be needed during a particular growing cycle. A list of the preprogrammed seeds appears on page 14. Press SELECT to choose your seed. Repeat for each of the zones you wish to use.



Continued on next page

SETTING UP YOUR GROWING CYCLES (continued)

PROGRAMMING LIGHTING AND WATERING CYCLES

You can change the lighting and watering cycles for specific seeds, or new seeds that are not in the default programming cycles.

EDIT CYCLES

From the HOME screen (A), press SET UP. On the SET UP SCREEN (B), press EDIT PLANTS.

From the SEED LIST SCREEN (C), Select a plant and then the cycle will appear for that zone. On the EDIT SCREEN (D), you will see buttons for temperature, water and lights. You may also edit plant names on this screen for new seeds.

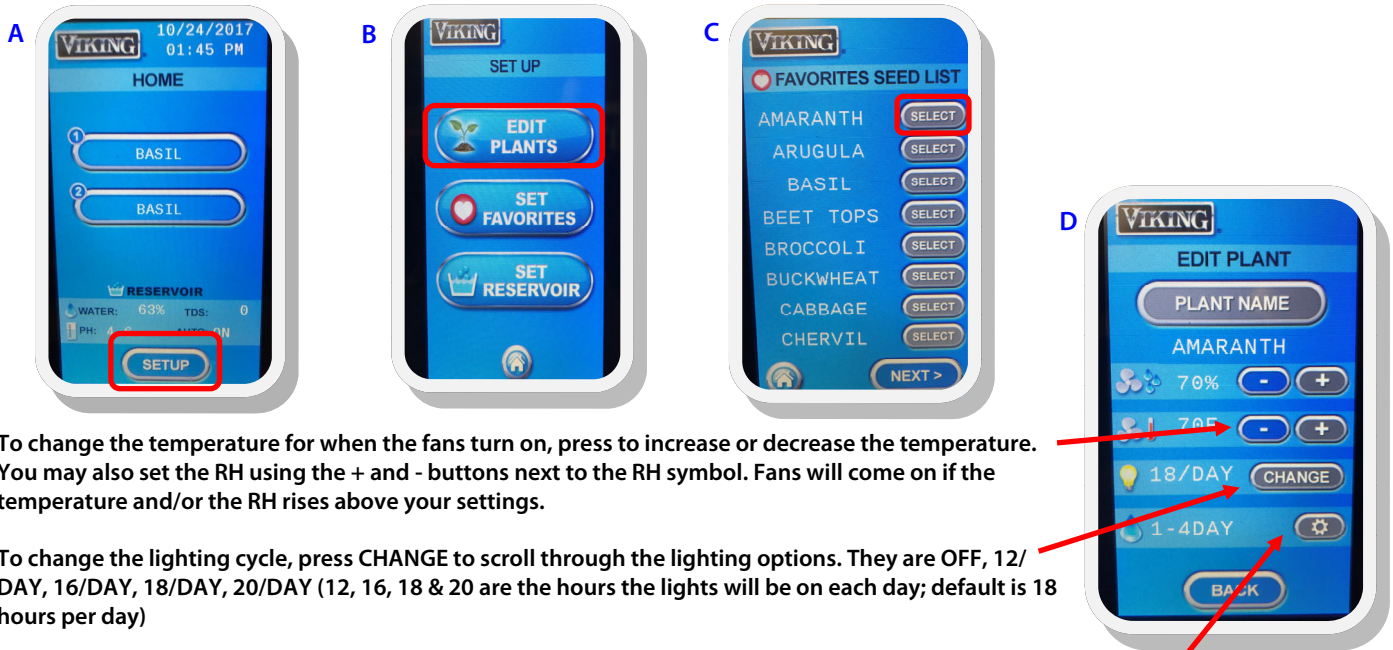

To change the temperature for when the fans turn on, press to increase or decrease the temperature. You may also set the RH using the + and - buttons next to the RH symbol. Fans will come on if the temperature and/or the RH rises above your settings.

To change the lighting cycle, press CHANGE to scroll through the lighting options. They are OFF, 12/DAY, 16/DAY, 18/DAY, 20/DAY (12, 16, 18 & 20 are the hours the lights will be on each day; default is 18 hours per day)

To change the watering cycle, press and use the arrows to select a watering cycle. The choices for watering cycle are:

- OFF: (no watering cycle)
- 1X DAY: (once each day)
- 2X DAY: (twice each day)
- 1-2 DAY: (once every other day)
- 1-3 DAY: (once every 3 days)
- 1-4 DAY: once every 4 days (default for most cycles; soil germination)
- 1-5 DAY: once every 5 days

Note: once or twice a day watering cycles are normally used for growing hydroponically, depending on your hydroponic growing media, i.e. perlite, mats, etc.)

You may also change the duration of the watering cycle anywhere between 1 and 10 minutes. Press the + and - buttons to increase or decrease the minutes. The default is 5 minutes. Press BACK when you are finished. You can select another plant to change or  press to return to the HOME screen.

To change a plant name, press PLANT NAME; a keyboard will appear and you can type in a new name. Press "✓" to save the name. You can then edit the cycles for your new seed.

SET YOUR FAVORITE PLANTS

You can reduce the size of your plant selection list from the home screen to just your favorites so you don't have to scroll through the entire list of saved plants to find your favorites; at the same time you will keep the programming for all of your plants, when you need them.

From the HOME screen, press SETUP, then from the SETUP screen, select SET FAVORITES. You will see the entire list of plants you have stored in the controller. To set your favorites, press the screen to the right of the plant names you would like to make your favorites. A little heart will appear, indicating that the plant is now a favorite. To de-select plants from the list, press the heart button until it disappears. You can scroll through the entire list using the NEXT button. To save your favorites, press the HOME button 

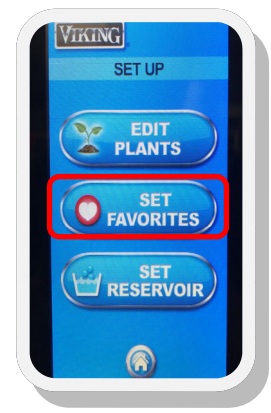

Continued on next page

SETTING UP YOUR GROWING CYCLES

TO START A GROWING CYCLE

On the HOME screen, select a seed for the zone you have just planted (Fig. 1), and you will enter the screen with the settings for that zone (Fig. 2).

Press START CYCLE (may also say RESTART CYCLE if the same cycle has been started in the past) and a cycle will begin. Then press the HOME button. Repeat for each zone that you have planted. Different zones can be started on different days, so not all have to be active at the same time and you can stagger growing cycles.

Fig. 1

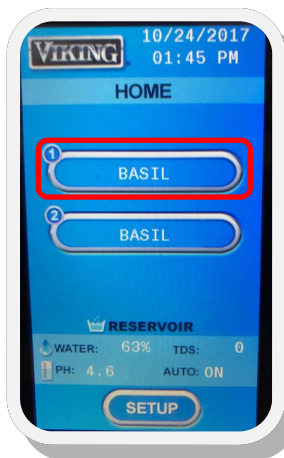

Fig. 2



OTHER FUNCTIONS IN THE ZONE SCREEN

If you plant something different or move trays from one zone to another, you can change to the cycle for a different seed by pressing CHANGE SEED. This will take you to your FAVORITES menu and you can select from your favorites.

If you would like to do an unscheduled watering, you can press the WATER NOW button and start a watering cycle. Monitor the watering cycle and press the WATER NOW button again when you would like the watering cycle to stop.

To cancel a growing cycle, go to the ZONE screen for the particular cycle you want the cancel. Press RESTART CYCLE. This will cancel the existing cycle

OTHER FUNCTIONS IN THE MAIN RESERVOIR SCREEN

From this screen, you can automatically drain and fill your cabinet using the DRAIN and FILL buttons. In addition to the regular DRAIN and FILL functions, there is also a RECYCLE function. This function can be used when all you want to do is exchange old water for new water in the cabinet.



CAUTION:

The cabinet MUST be hooked up to city water connection AND drain for doing any of these functions. It is equipped with a "last chance" safety option to not do an automatic drain. This is built in to make sure you are hooked up to municipal water and drain before you perform any drain or recycle operation. The screen will ask if you are sure before beginning the draining process. A draining screen will appear for you to monitor the progress on the draining cycle.

The cabinet will automatically circulate the water in the reservoir every hour. However, the CIRCULATE H2O button can be used when adding nutrients. It will activate the water pump to stir and distribute the water in the reservoir after adding nutrients. It will run for one minute in the GCV12.

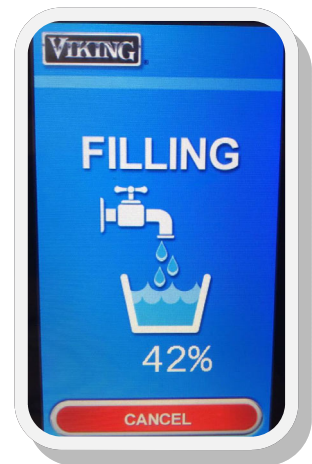
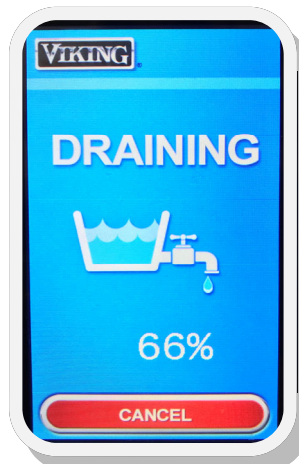
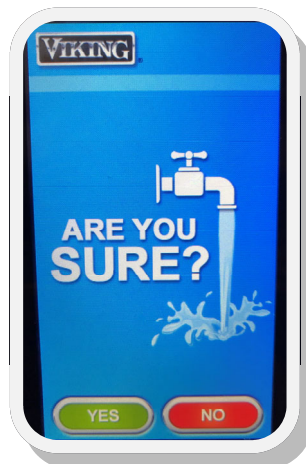
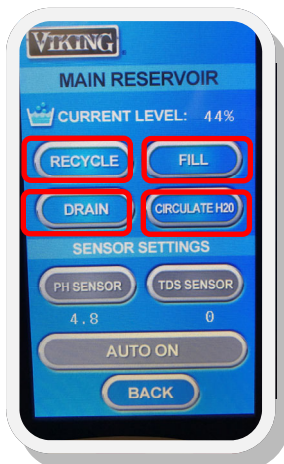

LETS' GROW!

PLANTING & GROWING

Planting and growing is easy. Follow these simple instructions. See the growing guide for specific plants on the next page.

- Please refer to the Growing Guide and Growing Tips on pages 16-17 for successful growing and harvesting of specific plants.
- See Sanitation and Safety Guidelines and FAQ's on pages 20-21 for safe growing and harvesting.

Materials Needed (planting using soil)*:

Potting Soil (sterile)	Screen/Mat	1—20 gal plastic tub (unsifted soil); smaller tub (sifted soil)
Seeds	Shaker	Humidity domes
10" x 20" planting trays**	Sifter	Measuring cups & spoons (for measuring seed quantities)
Misting bottle		

*If you are planting hydroponically, you will need a soil-free medium such as perlite or soil free mat instead of soil

**You may also use 10" x 10" planting trays; 2 will fit in the same space as a 10" x 20"

1. PLACE SOIL INTO ONE OF THE TUBS
2. USING SIFTER, SIFT SOIL INTO THE SECOND TUB; YOU WILL NEED ABOUT ONE TO 1.5 CUPS OF SIFTED SOIL PER TRAY TO BE PLANTED
3. ADD MORE SOIL TO THE FIRST TUB, ENOUGH TO FILL PLANTING TRAYS 1/2 TO 3/4 FULL AND MOISTEN SOIL ENOUGH TO MAKE IT DAMP AND CRUMBLY—NOT WET AND MUDDY; STIR WHEN ADDING WATER; DO NOT ADD WATER TO THE TUB OF

4. INSERT MATS INTO PLANTING TRAY(S)



5. PUT MOIST UNSIFTED SOIL IN TRAY(S), FILL TO 1/2 TO 3/4 FULL, AND SMOOTH



6. MEASURE OUT SEED QUANTITY AND SEED EVENLY WITH SHAKER (see amounts in Growing Guide, p. 15). SPRINKLE JUST ENOUGH SIFTED SOIL OVER SEEDS TO COVER THEM. IF THE TOP LAYER OF SIFTED SOIL IS DRY, MIST LIGHTLY TO MOISTEN (do not soak the top



7. SECURE HUMIDITY DOME. MAKE SURE DOME VENTS ARE CLOSED



8. PLACE TRAY(S) ON SHELF IN CABINET



9. SET PROGRAM FOR LIGHT AND WATERING SCHEDULE ACCORDING TO THE GROWING GUIDE

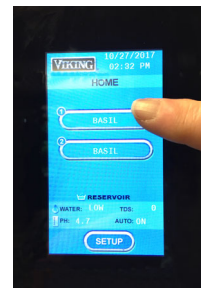

10. LEAVE DOME(S) ON FOR AT LEAST 48 HOURS (until seeds sprout)

11. REMOVE THE HUMIDITY DOME(S) FOR THE REMAINDER OF THE GROWING CY-



12. HARVEST!

Harvest all greens



Or thin out greens and use as they

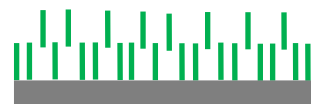

GROWING GUIDE

Seed	Sowing Amount seeds per 10"x20" tray	Dome On Time (germination)	Grow Time (harvest)	Watering Schedule ¹ (soil)	Harvest Yield per Tray*
Amaranth	2 tsp	2-3 days	2 weeks	1 every 4 days	3 oz (95g)
Arugula	1 tsp	2-3 days	3 weeks	1 every 4 days	4.7 oz (145g)
Basil	1 tsp	2-3 days	4-5 weeks	1 every 5 days	7.5 oz (235g)
Beet Tops	1/2 cup	2-3 days	2 weeks	1 every 4 days	4.3 oz (135g)
Broccoli	1 tbsp.	2-3 days	1 week	1 every 4 days	8.4 oz (260g)
Buckwheat	1/2 cup	2-3 days	1 week	1 every 3 days	13.3 oz (415g)
Cabbage	1 tbsp	2-3 days	2 weeks	1 every 4 days	5.2 oz (160g)
Chervil	2 tbsp.	8-10 days	3 weeks	1 every 4 days	4.5 oz (140g)
Chives	2 tbsp.	4-7 days	2 weeks	1 every 4 days	2.6 oz (80g)
Cilantro	1/4 cup	8-10 days	3 weeks	1 every 4 days	4.3 oz (135g)
Dill	1 tbsp.	4-7 days	3 weeks	1 every 4 days	3.5 oz (110g)
Fenugreek	1/4 cup	2-3 days	2 weeks	1 every 4 days	6.4 oz (200g)
Flax	1 tbsp	2-3 days	2 weeks	1 every 4 days	2.7 oz (85g)
Kale	1 tbsp	2-3 days	2 weeks	1 every 4 days	6.4 oz (200g)
Komatsuna	2 tsp	2-3 days	2 weeks	1 every 4 days	6.4 oz (200g)
Lemon Balm	2 tsp	8-10 days	4 weeks	1 every 4 days	3 oz (95g)
Lentils	1/2 cup	2-3 days	1 week	1 every 4 days	5.7 oz (180g)
Lettuce	1 tbsp	4-7 days	3 weeks	1 every 4 days	2.1 oz (65g)
Marjoram	1 tsp	4-7 days	4 weeks	1 every 4 days	1.3 oz (40g)
Mizuna	1 tbsp	2-3 days	2 weeks	1 every 4 days	4 oz (124g)
Mustard	1 tbsp	2-3 days	2 weeks	1 every 4 days	6.4 oz (200g)
Nasturtium	1/2 cup	4-7 days	1-2 weeks	1 every 4 days	9.3 oz (290g)
Oregano	1 tsp	4-7 days	4 weeks	1 every 5 days	1 oz (32g)
Parsley	1 tbsp	4-7 days	3 weeks	1 every 4 days	5.4 oz (168g)
Pea, Sugar	1 cup	2-3 days	2 weeks	1 every 4 days	9.6 oz (300g)
Pea	1 cup	2-3 days	2 weeks	1 every 4 days	9.6 oz (300g)
Peppergrass	1 tbsp	2 days	2 weeks	1 every 4 days	4.5 oz (140g)
Radish	2-3 tbsp.	2-3 days	1 week	1 every 4 days	10.3 oz (320g)
Sage	2 tbsp	2-3 days	2 weeks	1 every 4 days	2.7 oz (85g)
Savory	1 tbsp	2-3 days	2 weeks	1 every 5 days	1.1 oz (35g)
Shiso	2 tsp	2-3 days	2-3 weeks	1 every 4 days	4.1 oz (128g)
Sorrell	2 tsp	2-3 days	2 weeks	1 every 4 days	3 oz (92g)
Sorrell, Ruby Veined	1 tsp	4-7 days	2-3 weeks	1 every 4 days	5.3 oz (165g)
Sunflower	1 cup	2-3 days	1 week	1 every 4 days	12.2 oz (380g)
Swiss Chard	1/2 cup	4-7 days	3 weeks	1 every 4 days	4.3 oz (134g)
Thyme	2 tsp	4-7 days	4 weeks	1 every 5 days	1.6 oz (50g)
Wheatgrass	1 cup	2-3 days	1 week	1 every 4 days	8.3 oz (258g)

NOTE: If sowing multiple varieties of seeds in the same growing zone, set watering to once per 4 days

*Yields may vary depending on seed variety, quality and growing conditions

¹For soil-free (hydroponic) growing, change watering cycle to once or twice per day; frequency is dependent on type of media that is used

GROWING DO'S AND DON'T'S

DO MAINTAIN TEMPERATURE AND HUMIDITY

Keep the room temperature between 55°F and 90°F (13°C and 32°C), and the humidity level in the cabinet between 30 and 60%.

DO KEEP IT CLEAN

Keep your growing environment clean. Clean the reservoir, reservoir filter and growing shelves every month according to the cleaning instructions on pages 17-19.

DON'T OVERWATER

Overwatering, especially at the beginning of the growing cycle can bring on mold and mildew. Most watering cycles have been pre-set for every 4 days and are usually sufficient for most plants, depending on the ambient temperature and humidity.

DO USE HUMIDITY DOMES DURING GERMINATION

The humidity domes increase the temperature and humidity to enhance germination. Keep them on the trays for the first 2-3 days, with the vents closed. Remove them when the seeds start to sprout.

DO USE PROPER SOIL OR MEDIA

Purchase clean potting soil from a reputable supplier. Make sure there is a filter pad in the bottom of the tray to keep soil from running into the water reservoir. We have had good results with Happy Frog brand potting soil, but there are many choices on the market. Don't use garden soil as it can get compacted and interfere with proper watering. If growing hydroponically, purchase mats or other hydroponic media such as perlite. Note: depending on the media, growing results may be different than soil. You may have to experiment with hydroponic media to determine which type works best for growing different plants. There are many resources online describing the use, pros and cons of the different types of media that are available. For discussion on hydroponic growing media, consult www.epicgardening.com

DON'T OVERFEED

Overfeeding can cause damage to plants. For best results follow the instructions on your nutrient bottle. Most quick growing micro greens (one to two weeks) do not require any nutrients. Greens with a longer growing cycle (herbs, arugula, etc.) or greens that are used for multiple harvests require nutrients, and should only be added after week one or two at the earliest.

DO KEEP pH LEVELS BETWEEN 5 AND 7

Balance your pH level at 5 in the beginning of the growing cycle for best results, as the pH is likely to increase as the cycle goes on. The cabinet is equipped with an automatic dosing system to keep pH levels from going too high. Be sure to check your dosing bottle regularly to make sure it doesn't run out. Low pH is rare, but if it occurs citric acid (organic) or potassium hydrochloride can be used to raise the level. Make sure they are mixed according to manufacturer's direction and used sparingly. These and other hydroponic supplies can be purchased at a local hydroponic growing store or on the internet.

DO SOW SEEDS A LITTLE ON THE HEAVY SIDE

Thin out young plants and allow others to grow and fill out.

DO USE HYDROGEN PEROXIDE

If you accidentally keep your humidity domes on too long or overwater your seeds, they may develop powdery mildew. You can spray them with a mixture of hydrogen peroxide and water. Mix 1 tbsp. of hydrogen peroxide (17-35% food grade) in 1 quart of water. Spray only the soil, as the solution can cause plants to rot in on themselves.

DO LOVE YOUR PLANTS!

CLEANING AND MAINTENANCE

CLEANING THE RESERVOIR & IRRIGATION SYSTEM

1. Make sure cabinet is connected to city drain and water. If you are not hooked up to a drain and city water you will need to manually drain and fill the cabinet; if this is the case, connect the drain fitting to a hose that runs to a drain or sink. Do not activate the DRAIN function until you have a place to drain the water with a hose to a sink or drain, observing all municipal codes. Used water from the cabinet is not potable.
2. Remove the bottom drawer(s)
3. From the HOME screen, press SETUP
4. In the SETUP screen, press SET RESERVOIR
5. Press DRAIN. The next screen that appears will ask if you are sure. Double check that the cabinet is hooked up to a drain. Otherwise it will drain onto your floor! If you are not sure, press no and double check. If you are sure, press YES.
6. The cabinet will start to drain the reservoir. This may take up to 20 minutes. Once the reservoir has been drained, wipe off any dirt with a clean rag.
7. Add your preferred cleaning solution (i.e. hydrogen peroxide mixture) into the reservoir. Follow the guidelines on the label of the agent. The capacity of the GCV12 is 3.25 gallons. H₂O₂ concentration should be 5 tsp per one gallon of water.
8. From the HOME screen, press SET RESERVOIR, then FILL. Filling should take approximately 20 minutes.
9. When the reservoir has refilled, from the HOME screen press ZONE 1 and then WATER NOW so that the cleaning solution flows through the cabinet's piping system to ZONE 1
10. Repeat step 9 for ZONE 2
11. Once the zones and reservoir are cleaned, from the HOME screen, press SETUP, SET RESERVOIR, then RECYCLE. This will drain the reservoir of the cleaning solution and then refill it with fresh water for your next growing cycle.



CLEANING AND MAINTENANCE (continued)

CLEANING THE GROWING DRAWERS Clean your grow drawers between each harvest. However, keep a close eye on the environment and immediately clean any mold or organic matter.



Do not use any chemically damaging or toxic cleaning products such as bleach. Do not use stainless steel cleaner on the interior of the cabinet. Using chemical cleaning products can be toxic and also damage the stainless steel drawers and cabinet. You can use 30% hydrogen peroxide to clean the reservoir and water lines (5 teaspoons per gallon of water). Read all warning labels on the hydrogen peroxide or other cleaning products.

Keep your growing environment clean.
Clean the reservoir, reservoir filter and grow drawers every month.

GENERAL STAINLESS STEEL CLEANING

Clean the exterior of your cabinet when fingerprints and large amounts of dust appear on the outer surfaces. Using stainless steel cleaner from your local hardware store, spray on and wipe down with a cloth going with the grain (As seen in the pictures). **DO NOT USE STAINLESS STEEL CLEANER IN THE RESERVOIR OR IN THE DRAWERS.** Stainless steel cleaner is to only be used on the outer surfaces of your cabinet!

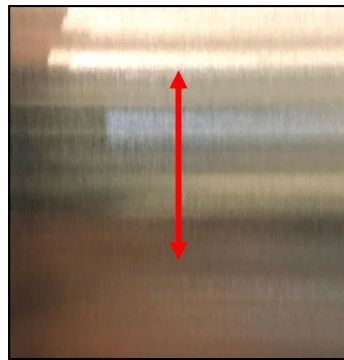

CLEANING CAUTIONS

When you wipe down the reservoir, do not knock the pumps, misalign the pipes or the sensors.

Draining the reservoir sends water down and out from the drain hose. Water from the cabinet is not for drinking as biological residues may still be present and could be harmful.

Do not use steel wool pads to clean the reservoir as they will damage the steel and its rust-resistant finish.

Do not use detergents or solutions that contain chlorides, ammonias, alkalis or abrasive cleaners. Use only environmentally safe, non-toxic solutions in the manufacturers' recommended concentration. Non-chlorine bleach from an environmentally-friendly company may be used in accordance with the guidelines on the packaging.

DAMAGE TO STAINLESS STEEL IS PERMANENT, COSTLY TO REPAIR, AND IS NOT COVERED BY THE WARRANTY

PERIODIC MAINTENANCE PROCEDURES

INSIDE THE RESERVOIR

A. DRAIN, CLEAN AND FLUSH RESERVOIR (Monthly)

SEE INSTRUCTIONS ON PAGE 17

B. CHANGE FILTER (30-45 days*—more often in areas with hard water; filter is washable for extended use)

1. Locate the filter (large blue or white canister in the reservoir) and unscrew the canister counter clockwise. Make sure to support very well the filter mounting bracket while unscrewing filter in order to reduce the risk of breaking mount.
2. Remove and discard excess water.
3. Change the filter and screw the canister back into place by lining tabs up with head and cartridge. Push until it bottoms out, then twist clockwise.

You may need to re-prime the pump after this process. See instructions on how to prime the pump on page 10.

*How often you change your filter is dependent on whether you are growing in soil or hydroponic media. Once you get through a few growing cycles, you will be able to determine how often it should be changed. One indicator the filter needs to be changed is inadequate water flow to the trays during a



Water Filter



Water circulation pump; white filter cap at bottom

C. CHECK AND CLEAN FILTER CAP (Monthly)

1. Remove the small white cap at the bottom of the blue cylindrical circulation pump.
2. Rinse the cap.
3. Place the cap back onto the pump

*If the water flow to your growing drawers is inadequate during a watering cycle, check the filter cap to see if it needs to be

INSIDE THE GROWING ZONES

A. CLEAN DRAWERS (Monthly)

1. Remove a drawer from the cabinet
2. Use a clean cloth with hot soapy water or hydrogen peroxide solution to wipe down the grow drawer; make sure the drain holes are cleared of any debris.
3. Rinse off the drawer with clean water
4. Dry with clean cloth
5. Replace in cabinet
6. Repeat steps for all drawers

REPLACING THE LIGHTS

Occasionally you may need to replace a light bulb. It is a simple process, similar to changing the bulb on an aquarium hood. For part number, see the list on page 26.



NOTE: T5 growing lights running at the default time of 18 hours per day is considered high use and the efficiency of the bulbs will reduce approximately 10% after 20,000 hours. Bulbs should be replaced every 18-24 months to ensure best

- Remove the diffuser shield by pushing it up with both hands, then pushing it back far enough for the front to drop down, and then pull out.
- Grab each end of the bulb (metal ends of tube), rotate clockwise until you can pull the bulb out.
- Insert the ends of the new bulb into the black ends of the ballast, then turn counter-clockwise until the bulb snaps into place.
- Replace the shield by lifting it up and back over the notch in the back of the cabinet, push up the front until it clears the front of the diffuser frame, pull forward and drop into place.

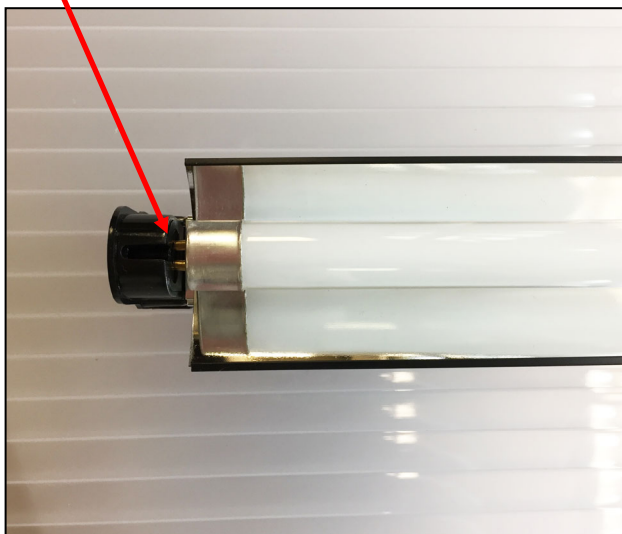
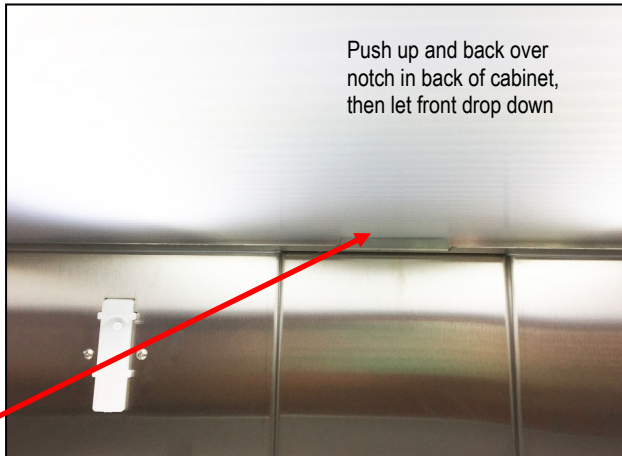

For your health and safety, please read the information below regarding sanitation, safe growing and food safety.

Micro greens and herbs are not sprouts, but rather, baby plants with intense flavor and nutrients. There are differences in growing and harvesting micro greens that make them much safer than sprouts.

Starting with Seeds

Make sure that all seeds you buy have been handled as a food crop, not a farm crop. Seeds that have been in contact with animals or animal waste could be contaminated with salmonella or E.coli O157 H7 and could lead to food poisoning. Reputable seed suppliers test all lots of seed for contamination.

Make sure that each container of seed is labeled with the name of the seed producer or distributor, the lot number and the country of origin.

Keep records to ensure trace-back and recall procedures.

Sanitation

Always use clean seed, as stated above, and soil, tested for E. coli and salmonella.

Sanitize equipment; regularly clean and sanitize all growing drawers, cabinet and reservoir with hydrogen peroxide rate recommended below. We recommend a thorough cleaning/disinfecting weekly, or when new trays are planted.

Don't let greens or seeds come into contact with manure or other contaminated organic material.

Hands and equipment must be kept clean at all times for handling micro greens. We recommend food handling gloves during planting and harvesting.

Water in the reservoir should be clean, potable water, tested for bacterial contamination.

It is recommended that 2% chlorine from calcium hypochlorite be used as a seed sanitation method if your intention is sprouting. This is not necessary for micro greens, but can be done as an extra precaution.

Using Calcium Hypochlorite

Rate: 3 ounces calcium hypochlorite in 1 gallon of warm water. Mix thoroughly and soak seed for 20 minutes. Rinse seed thoroughly in clean water, then finish soaking time, if required, in clean water. Avoid breathing the fumes of chlorine. Masks should be worn to filter the fumes if you choose this method.

Using Hydrogen Peroxide:

Soak seeds in hydrogen peroxide. Add 5 ounces of 5% hydrogen peroxide and one ounce distilled vinegar to one quart of room temperature water. Pour the solution over the seed and let stand for 5 minutes, making sure that all of the seed is in contact with the solution. Drain and rinse the seeds in clean water several times to make sure the solution has been removed. Plant seed as usual. This again is recommended for sprouting, but not necessary for growing micro greens and herbs.

Growing Conditions

The environment in which E. coli and salmonella thrive is warm and moist. Most commercial sprouts are grown in large tanks of water, which tumble the seeds much like a washing machine tumbles clothes. In these conditions, if one seed is contaminated, it will be spread to all of the sprouts in the water bath.

Micro greens are not grown in water. We recommend growing them in sterile soil or other sterile media. While a sprout bath spreads pathogens from one sprout to another, soil acts like a filter, actually removing the source of contamination.

Harvesting

While a sprout is consumed whole, including the leaves, roots and seed husk, micro greens are newly germinated, small plants like you'd find in any garden. All micro greens should be harvested with clean hands, or using food handling gloves, clipped at least 2" away from the root system and soil, using clean disinfected scissors. Ensure all debris is removed from micro greens and cleaned thoroughly before consumption.

Refrigerate cut micro greens, except basil (cut basil is delicate and does not like the cold). Treat them and any foods containing them as you would any nutritious food.

If you love sprouts, consider growing micro greens. Their bright and intense flavor will be even more enjoyable now that you have confidence that they are also safe

FREQUENTLY ASKED QUESTIONS & TROUBLESHOOTING

How much soil should I put in my trays?

You should fill each tray 1/2 to 3/4 full with sterile potting soil. Make sure the soil is well moistened, but not overly muddy or soupy. See Resources page 25 for some brands we have found to be high quality soils. For seeds with a shorter life cycle like pea shoots, radishes, wheatgrass (1-2 weeks), 1/2 full is adequate. For seeds with longer life cycles such as basil, oregano, arugula, etc., go with 3/4 full.

Can I mix in my seeds or cover with dirt?

For the best results for germination, sprinkle them with a fine layer of sifted soil, just enough to cover the seeds. Usually 1 to 1-1/2 cups of sifted soil works. The finer soil spreads easily and provides a nice blanket over the seeds for germination so that more seeds sprout and at the same rate.

When should I use plant nutrients?

The cabinet will display total dissolved solids (TDS) of the water in the reservoir. Note what the TDS is when you first fill the reservoir and try to maintain a TDS of 100-250 above that number. Add 2.75 oz. (80ml) of nutrients at a time, wait 15 minutes to adjust the TDS.

Is the cabinet pre-programmed?

Yes, the cabinet is pre-programmed for the seeds listed on page 15 for soil growing. There are a few empty positions open in the menu for adding more seeds and you can erase and replace items in the seed menu. You can also designate your favorite seeds for frequently used cycles. All of the seed programs are adjustable for light and watering schedules.

How often should I perform maintenance on my cabinet?

The cabinet requires frequent monitoring and care. It should be inspected thoroughly and cleaned at least once a month. This may vary with your usage, depending on the number and types of plants, nutrients and TDS build-up and growing medium (soil vs. hydroponic). Please refer to maintenance and cleaning procedures in this manual.

Does the water reservoir keep itself filled?

Yes. If your cabinet has been plumbed and hooked up to municipal water supply, then it is pre-programmed exchange the water in the reservoir once a week and top off as needed.

What do I do if the reservoir won't recycle?

Check to ensure that the connection on your city drain is open and free of blockage. If the cabinet is new, it may not be primed. See instructions in this manual on page 10 for priming the pump.

What do I do if there is a zone that won't water?

Make sure only one zone is being watered at a time. Only one zone can be watered at one time, so watering schedules for each zone will be staggered an hour apart, if they are programmed to water at the same time. Check the programmed schedule to ensure it is not programmed to be OFF. If still no watering, access the reservoir and insure that the pump is on and primed.

What if I see a weak/no water supply to the drawers during a watering cycle?

It's likely that the screen over the filter is clogged with debris and needs to be cleaned or the filter needs to be replaced. See maintenance and cleaning instructions on page 19.

What if the drawers don't appear to be draining properly?

Check the drain holes at the back of the drawers and clear them if they are blocked. A pipe cleaner is ideal for this maintenance.

MICRO GREEN PROBLEMS

WHITE MOLD



Identification	Remedy
<p>White mold looks like a spider web crawling across the surface of the growing media. It starts out in one area in a small, wispy ball and then expands quickly over the growing media.</p>	<ul style="list-style-type: none"> • Make sure your trays are CLEAN before you plant • Decrease the humidity by increasing air circulation • Decrease the seed density of your future plantings, especially for mucilaginous seeds • Try using some grapefruit seed extract mixed with water as an organic solution

SLOW GERMINATION



Identification	Remedy
<p>Most micro green seeds germinate in 2-4 days, but some may take a bit longer. If you're seeing germination times that are longer than what is outlined in the table on page 15, something is wrong.</p>	<ul style="list-style-type: none"> • Increase moisture in the tray by misting or running an unscheduled watering cycle • Do a germination test on a paper towel to see if the seed is bad. Place a paper towel in a growing tray, moisten it by misting with a mister and sprinkle the seeds on top. Cover with a propagation dome and see if they sprout.

CLUMPY MICROGREENS



Identification	Remedy
<p>When you're spreading your seed out in trays, it can be difficult to get an even spread. If you plant too densely, they will clump together, especially if their mucilaginous. When they sprout, a few of the seedlings will push the rest of them up into the air, suspending the roots and possibly bringing dirt along with them. It makes harvesting difficult.</p>	<ul style="list-style-type: none"> • Decrease total seed volume planted in each tray • Spread seeds more evenly throughout the tray

FAILURE TO THRIVE



Identification	Remedy
<p>The greens look weak and pale. This is an all encompassing condition that could result from a number of factors. It is difficult to troubleshoot this condition if all of the other conditions above have been addressed.</p> <p>The weakness could be due to a lack of moisture control—either too dry or too wet. In some cases the seed is not properly planted, or the humidity dome is removed at the wrong time.</p>	<ul style="list-style-type: none"> • Make sure to read the seed growing instructions on the packets of seeds • Stick to a normal watering schedule • Make sure you leave the humidity domes on for an adequate amount of time • If growing hydroponically, check your nutrient concentration; make sure nutrients are mixed according to the manufacturers directions

RESOURCES

The growing cabinet comes with a starter set of domes and trays. An optional starter kit is available and includes growing trays, domes, mats, sifter, TDS calibration solution, PH kit, hydrogen peroxide, 20 gallon plastic tub (for mixing/sifting soil) and measuring syringe (for adding nutrients).

Many supplies, including seeds and growing media, can be found at local greenhouses and garden supply sellers. The internet is a great resource for finding everything you need for your growing cabinet. A list of some resources is on the next page.



Growing trays (with drain holes) and vented domes



TDS reader: for measuring the initial TDS of your water supply



Plastic tubs for mixing and sifting soil



Sterile soil or hydroponic growing media



Growing mats/filters to keep soil from running out of the trays into the water. Thicker mats can be used for hydroponic growing



Seeds: purchase from reputable supplier



Rockwool or stonewool starter cubes/trays for hydroponic growing. Perlite, coconut coir and other media may also be used. For discussion on hydroponic growing media, consult www.epicgardening.com

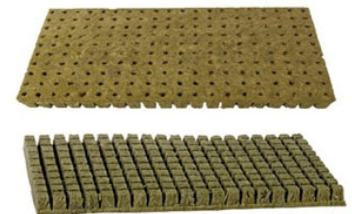

Sifter to sift dry soil to cover seeds for germination



Measuring syringe to add nutrients



Plant food: for hydroponic growing or seeds with longer growing cycles. Seeds with shorter growing cycles get enough nutrients from the soil

PH kit: PH#4 and PH#7 bottles to calibrate the pH probe.

TDS 1000 EC ppm solution: To calibrate total dissolved solids probe



List of brands for supplies*



Growing trays
(with drain holes)
and vented
domes:
Mondi™
Super Sprouter™
Sun Systems™



TDS reader:
Milwaukee™



Sterile soil:
Fox Farms Happy Frog™
Miracle Gro™

Plastic tub for mixing and sifting soil: Rub-
bermaid™

Hydroponic growing media
(perlite, rockwool):
Handy Pantry™
Miracle Gro™
Therm-O-Rock™
Viagrow™
Plant It™
Grodan™



Growing mats/filters:
Handy Pantry™

pH and TDS Calibration Solutions:
Nutradip™
General Hydroponics™

For discussion on hydroponic
growing media, consult
www.epicgardening.com



Seeds:
Johnny's Selected Seeds™
Burpee™
Cahaba Clubs Herbal Outpost™
Eden Brothers™

pH down and pH up solutions*:
Nutradip™
General Hydroponics™
Botanicare™



Plant food:
Miracle Gro™
Jungle Juice™
General Hydroponics Flora Series™
Fox Farm Gringo Rasta,™ Bush Doc-
tor™ and Hydroponic Trio™



* Do not use solutions intended for swimming pools.
These are not safe for plants.

* This is not a complete list or an endorsement of these products. Brands are trademarked and not affiliated with Viking Range, LLC

PLUMBING DIAGRAM



CAUTION: Use only (OEM) original equipment manufacturer replacement parts. Using unauthorized parts may cause serious injury or damage to the cabinet. Replacement parts should be installed by a qualified service technician.

Contact Viking Range Preferred Service at 888-845-4641 with your model and serial number for replacement parts.

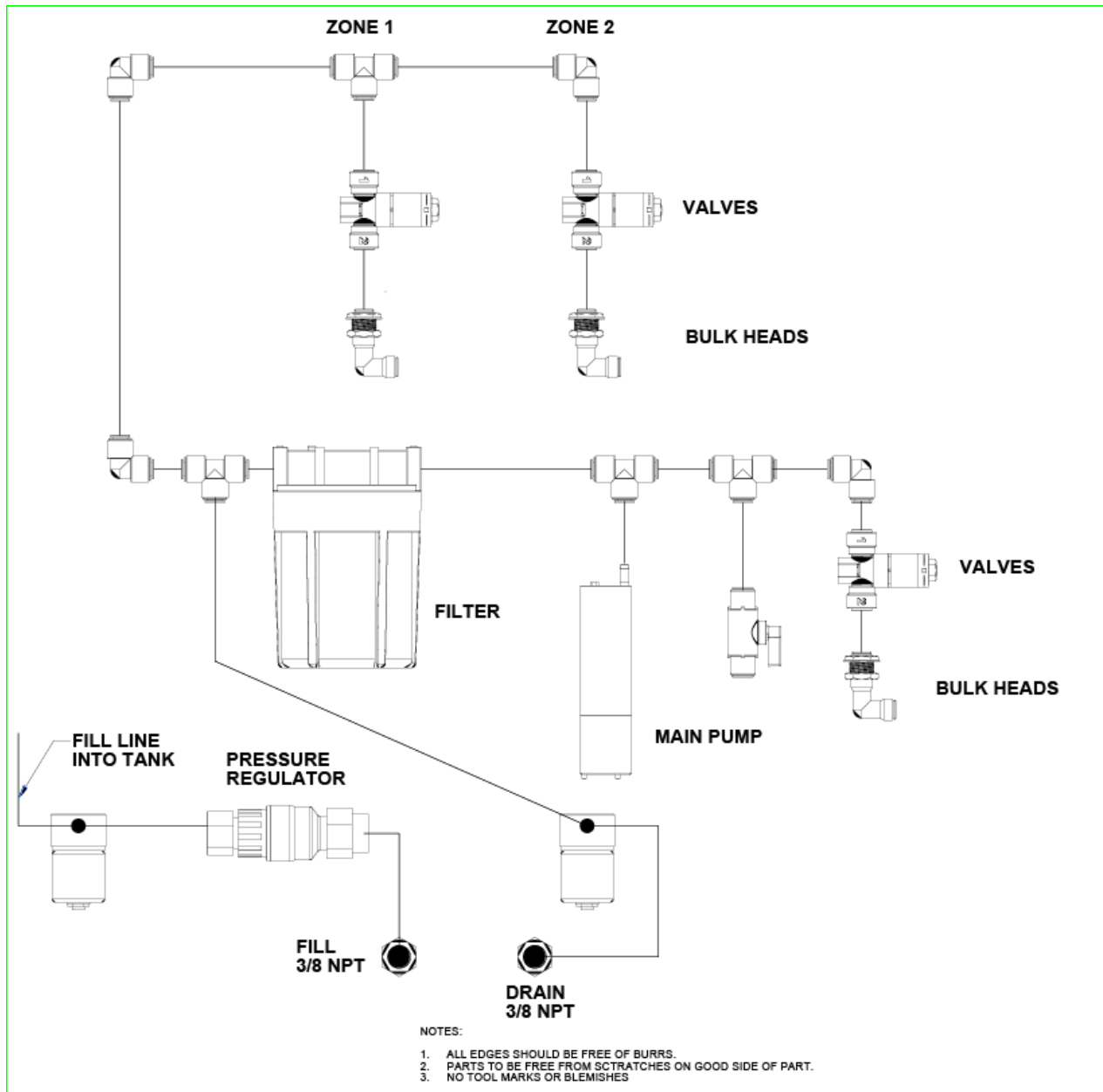

SERVICE INFORMATION

If service is required, call your authorized service agency.

Have the following information readily available:

- Model number
- Serial number
- Date purchased
- Name of dealer from whom purchased

Clearly describe the problem that you are having. If you are unable to obtain the name of an authorized service agency, or if you continue to have service problems, contact Viking Range at (888) 845-4641 or write to:

VIKING RANGE, LLC
PREFERRED SERVICE
111 Front Street
Greenwood, Mississippi 38930 USA

Record the information indicated below. You will need it if service is ever required. The serial number and model number for your appliance are located on the serial tag:

Model No. _____ Serial No. _____

Date of Purchase _____ Date Installed _____

Dealer's Name _____

Address _____

If service requires installation of parts, use only authorized parts to insure protection under the warranty.

Keep this manual for future reference.

HOUSEHOLD PRODUCT WARRANTY

MICRO GREEN AND HERB CABINET WARRANTY

TWO YEAR FULL WARRANTY

Micro green and herb cabinets and all of their component parts, **except as detailed below**†‡, are warranted to be free from defective materials or workmanship in normal residential use for a period of two (2) years from the date of original retail purchase. Viking Range, LLC, warrantor, agrees to repair or replace, at its option, any part which fails or is found to be defective during the warranty period.

***FULL NINETY (90) DAY COSMETIC WARRANTY:** Product is warranted to be free from cosmetic defects in material or workmanship (such as scratches on stainless steel, paint/porcelain blemishes, etc.) for a period of ninety (90) days from the original retail purchase or closing date for new construction, whichever period is longer. Any defects must be reported to the selling dealer within ninety (90) days from date of original purchase. Viking Range, LLC uses high quality processes and materials available to produce all color finished. However, slight variation may be noticed because of the inherent differences in painted parts and porcelain parts as well as differences in kitchen lighting, product locations and other factors. Therefore, this warranty does not apply to color variation attributable to such factors.

†FULL NINETY DAY (90) WARRANTY IN "RESIDENTIAL PLUS" APPLICATIONS: This full warranty applies to applications where use of the product extends beyond normal residential use, but the warranty period for products in such applications is ninety (90) days. Examples or applications covered by this warranty are bed and breakfasts, fire stations, private clubs, churches, yachts, etc. Under this "Residential Plus" warranty, the product, its components and accessories are warranted to be free from defective material or workmanship for a period of ninety (90) days from the date of original retail purchase. This warranty excludes use of the product in all commercial locations such as restaurants, food service locations and institutional food service locations.

‡CONSUMABLE COMPONENTS: Consumable components such as light bulbs and filters are not covered by this warranty. Refer to the warranties from the original manufacturers of these items.

TERMS AND CONDITIONS

This warranty extends to the original purchaser of the product warranted hereunder and to each transferee owner of the product during the term of the warranty and applies to the products purchased and located in the United States, Canada, Mexico and the Caribbean (excluding Cuba, Dominican Republic and Haiti). Products must be purchased in the country where service is requested. If the product or one of its component parts contains a defect or malfunction during the full warranty period after a reasonable number of attempts by the warrantor to remedy the defect or malfunction, the owner is entitled to either a refund or replacement of the product or its component part or parts. Replacement of a component part includes its free installation, except as specified under the limited warranty. Under the terms of this warranty, service must be performed by a factory authorized Viking Range, LLC service agent or representative. Service will be provided during normal business hours, and labor performed at overtime or premium rates shall not be covered by this warranty.

Owner shall be responsible for proper installation, providing reasonable and necessary maintenance, providing proof of purchase upon request, and making the appliance reasonable accessible for service. The return of the Owner Registration Card is not a condition of warranty coverage. You should, however, return the Owner Registration Card so the Viking Range, LLC can contact you should any question of safety arise which could affect you.

WHAT IS NOT COVERED BY THIS WARRANTY: THIS This warranty shall not apply to damage resulting from abuse, failure to provide reasonable an necessary maintenance, accident, delivery, negligence, natural disaster, loss of electrical power to the product for any reason, alteration, outdoor use, improper installation, improper operation, or repair or service of the product by anyone other than an Authorized Viking Range, LLC service agency or representative. This warranty does not cover commercial usage.

LIMITATIONS OF REMEDIES AND DURATION OF IMPLIED WARRANTY

OWNER'S SOLE AND EXCLUSIVE REMEDY FOR A CLAIM OF ANY KIND WITH RESPECT TO THIS PRODUCT SHALL BE THE REMEDIES SET FORTH ABOVE. VIKING RANGE, LLC IS NOT RESPONSIBLE FOR CONSEQUENTIAL OR INCIDENTAL DAMAGE, INCLUDING BUT NOT LIMITED TO FOOD OR MEDICINE LOSS, DUE TO PRODUCT FAILURE, WHETHER ARISING OUT OF BREACH OF WARRANTY, BREACH OF CONTRACT OR OTHERWISE. Some jurisdictions do not allow the exclusion or limitation of incidental or consequential damages, do the above limitation may not apply to you. **ANY IMPLIED WARRANTIES OF MERCHANTABILITY OR FITNESS FOR A PARTICULAR PURPOSE APPLICABLE TO THIS PRODUCT ARE LIMITED IN DURATION TO THE PERIOD OF COVERAGE OF THE APPLICABLE EXPRESS WRITTEN LIMITED WARRANTIES SET FORTH ABOVE.** Some states do not allow limitations on how long an implied warranty lasts, so the above limitation may not apply to you.

WARRANTY SERVICE

To obtain warranty service, contact an authorized Viking Range, LLC service agent, or Viking Range, LLC, 111 Front Street, Greenwood, Mississippi 38930, *888) 845-4641. Provide model and serial number and date of original purchase or closing date for a new construction. For the name of your nearest authorized Viking Range, LLC service agency, call Viking Range, LLC.

IMPORTANT: Retain proof of original purchase to establish warranty period.

Specifications subject to change without notice.

Viking Range, LLC
111 Front Street
Greenwood, Mississippi 38930 USA
(662) 455-1200

For product information, call 1-888-(845-4641)
or visit the our web site at vikingrange.com