

FEATURES & BENEFITS



STAINLESS
SOLID



BLACK
SOLID



WHITE
SOLID

PERFORMANCE	<ul style="list-style-type: none"> • Uses less than 3 gallons (11,4 litres) of water to produce up to 23 lb (10,4 kg) of ice per day • Up to 12 lb (5,4 kg) in ice storage capacity • Crescent ice cube dimensions: 1/2" W x 3/4" H x 2 1/4" L (12,7 mm W x 19 mm H x 57 mm L) • On/Off switch is conveniently located on the grille • Available in 115 or 220-240 volts
INTERIOR/EXTERIOR	<ul style="list-style-type: none"> • No drain required • Door swing is field reversible, and is shipped right-hand hinged • Standard travel package includes door latch, ensuring safe-at-sea storage • Corrosion and UV resistant components provide product longevity in harsh environments
INTEGRATION	<ul style="list-style-type: none"> • Unit is designed to be built-in or can be freestanding • Black finish accepts a 1/4" (6,4 mm) custom insert panel • 1/2" (12,7 mm) flange mounts flush to cabinet

MODEL DETAILS

Model	Voltage/Hz	Door Swing	Finish	Shipping Weight
ULN-SP18FCS-03A	115 / 60	Field Reversible	Stainless Solid	65 lb (30 kg)
ULN-SP18FCS-20A	220-240 / 50	Field Reversible	Stainless Solid	65 lb (30 kg)
ULN-SP18FCB-03A	115 / 60	Field Reversible	Black Solid	68 lb (31 kg)
ULN-SP18FCB-20A	220-240 / 50	Field Reversible	Black Solid	68 lb (31 kg)
ULN-SP18FCW-03A	115 / 60	Field Reversible	White Solid	68 lb (31 kg)
ULN-SP18FCW-20A	220-240 / 50	Field Reversible	White Solid	68 lb (31 kg)

ACCESSORIES

Model	Description	Finish	Shipping Weight
ULAWATERHOOKUP	Braided water supply line kit	N/A	2 lb
U-POWERCORD-2056	Power Cord 220 - 240 V Great Britain/Ireland	N/A	N/A
U-POWERCORD-2256	Power Cord 220 - 240 V Australia/New Zealand	N/A	N/A
U-POWERCORD-2667	Power Cord 220 - 240 V Continental Europe	N/A	N/A
U-POWERCORD-3071	Power Cord 220 - 240 V China	N/A	N/A
U-POWERCORD-3111	Power Cord 220 - 240 V India	N/A	N/A

*Power cord type must be specified with each U-Line order; no additional cost for power cord.

DIMENSIONS

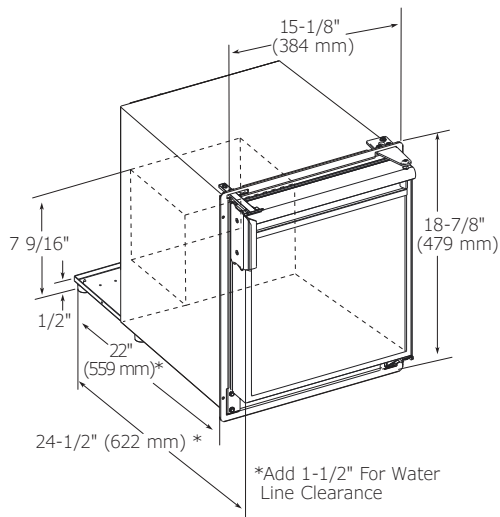

SPECIFICATIONS

Model	SP18FC
Amps: Running (115v)	2.5 amps
Amps: Running (220-240v)	1.2 amps
Amps: Max Start Up (115v)	18 amps
Amps: Max Start Up (220-240v)	6 amps
Control Type	Mechanical Dial
Defrost Type	Manual
Dimensions: Product Depth	24 1/2" (622 mm)
Dimensions: Product Height	18 7/8" (479 mm)
Dimensions: Product Width	15 1/8" (384 mm)
ENERGY STAR	N/A
Panel Type (Black Finish Only)	Insert
Panel Thickness (Black Finish Only)	1/4" (6,4 mm)
Panel Height (Black Finish Only)	13 15/32" (342 mm)
Panel Width (Black Finish Only)	12 15/16" (329 mm)
Ice Production Per Day	23 lb (10,4 kg)
Ice Storage	12 lb (5,4 kg)
Product Weight: Max	59 lb (26,7 kg)
Refrigerant Type	R134A
Sabbath (Star K Certified)	No

CABINET CUT-OUT

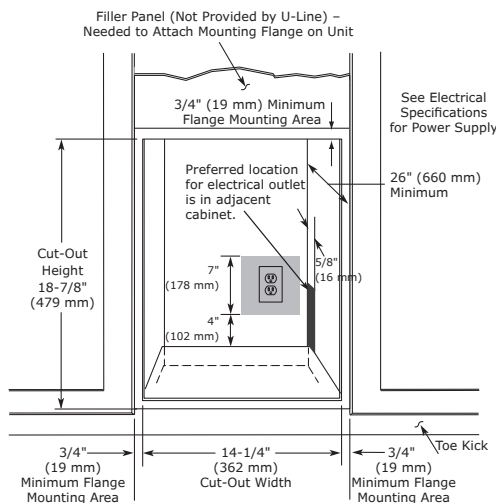

INSTALLATION NOTES

No additional clearance around sides, top or rear of unit is needed for ventilation.

Do not obstruct front grille air flow.

- 1 Year (parts & labor) / 5 year sealed system (parts)
- + **Additional 1 Year (parts & labor) warranty at no cost with product registration**

See complete warranty for details



UL listing only applies to 115 v models.
CE only applies to 220-240v models.

Please visit u-line.com to view this model's User Guide & Service Manual. All Specifications are subject to change without notice.