



T&S BRASS AND BRONZE WORKS, INC.

2 Saddleback Cove / P.O. Box 1088
Travelers Rest, SC 29690

Model No.

B-0850-01-PV

Item No.

Travelers Rest, SC: 800-476-4103 • Simi Valley, CA: 800-423-0150 • Fax: 864-834-3518 • www.tsbrass.com

This Space for Architect/Engineer Approval

Job Name _____ Date _____

Model Specified _____ Quantity _____

Customer/Wholesaler _____

Contractor _____

Architect/Engineer _____

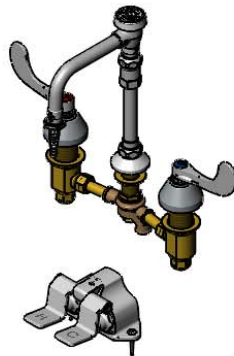
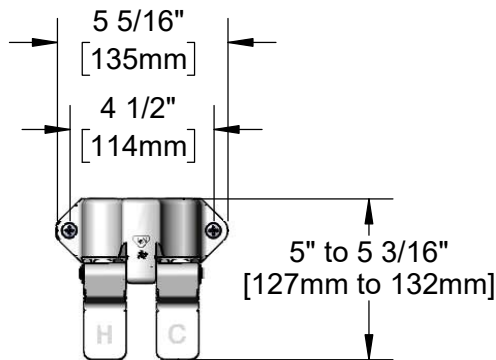

ADA Compliant

B-0968
3/8" NPT
Vacuum Breaker

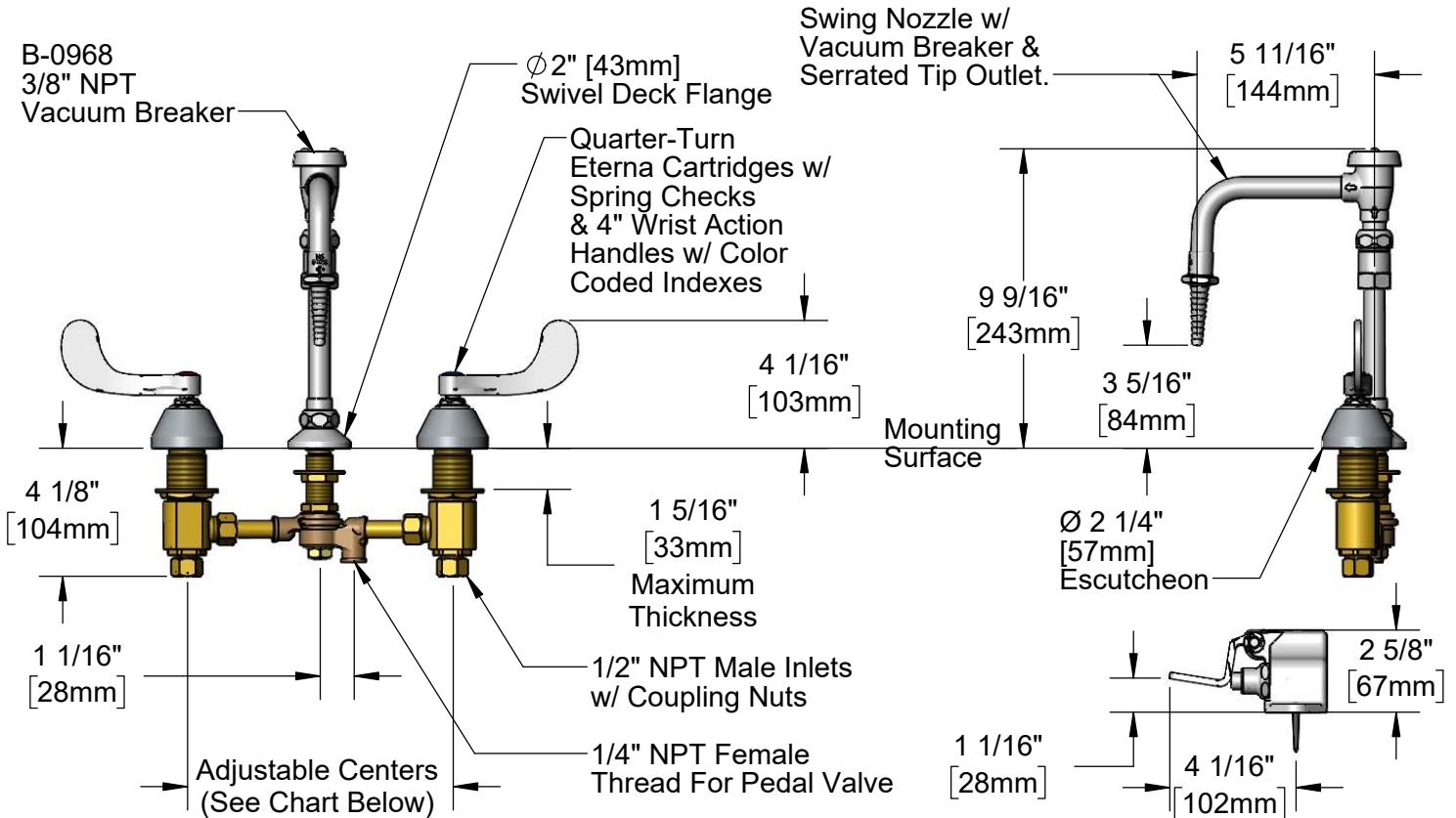

Rough-In Requirement:
Center Shank: ϕ 1" [ϕ 25mm] Mounting Hole
Hot/Cold Bodies: ϕ 1 1/2" [ϕ 38mm] Mounting Holes

Hot & Cold Center Sections Can be at Angle		Then Faucet Will Fit "X" with Standard 1/4" NPT Cross Pipes Furnished
	if "Y" is	
	1/2"	8"
	1"	7 3/4"
	1 1/2"	7 3/8"
	2"	7"

Product Specifications:

8" Concealed Widespread Mixing Faucet, Quarter-Turn Eterna Cartridges w/ Spring Checks, 4" Wrist Action Handles, Swing Nozzle w/ Vacuum Breaker, Pedal Valve Connection w/ Floor Mounted Double Pedal Valve & 1/2" NPT Male Inlets w/ Coupling Nuts

Product Compliance:

ASME A112.18.1 / CSA B125.1
NSF 61 - Section 9
NSF 372 (Low Lead Content)
ASSE 1001 (VB)
ANSI A117.1 (ADA)



T&S BRASS AND BRONZE WORKS, INC.

2 Saddleback Cove / P.O. Box 1088
Travelers Rest, SC 29690

Model No.

B-0850-01-PV

Item No.

Travelers Rest, SC: 800-476-4103 • Simi Valley, CA: 800-423-0150 • Fax: 864-834-3518 • www.tsbrass.com

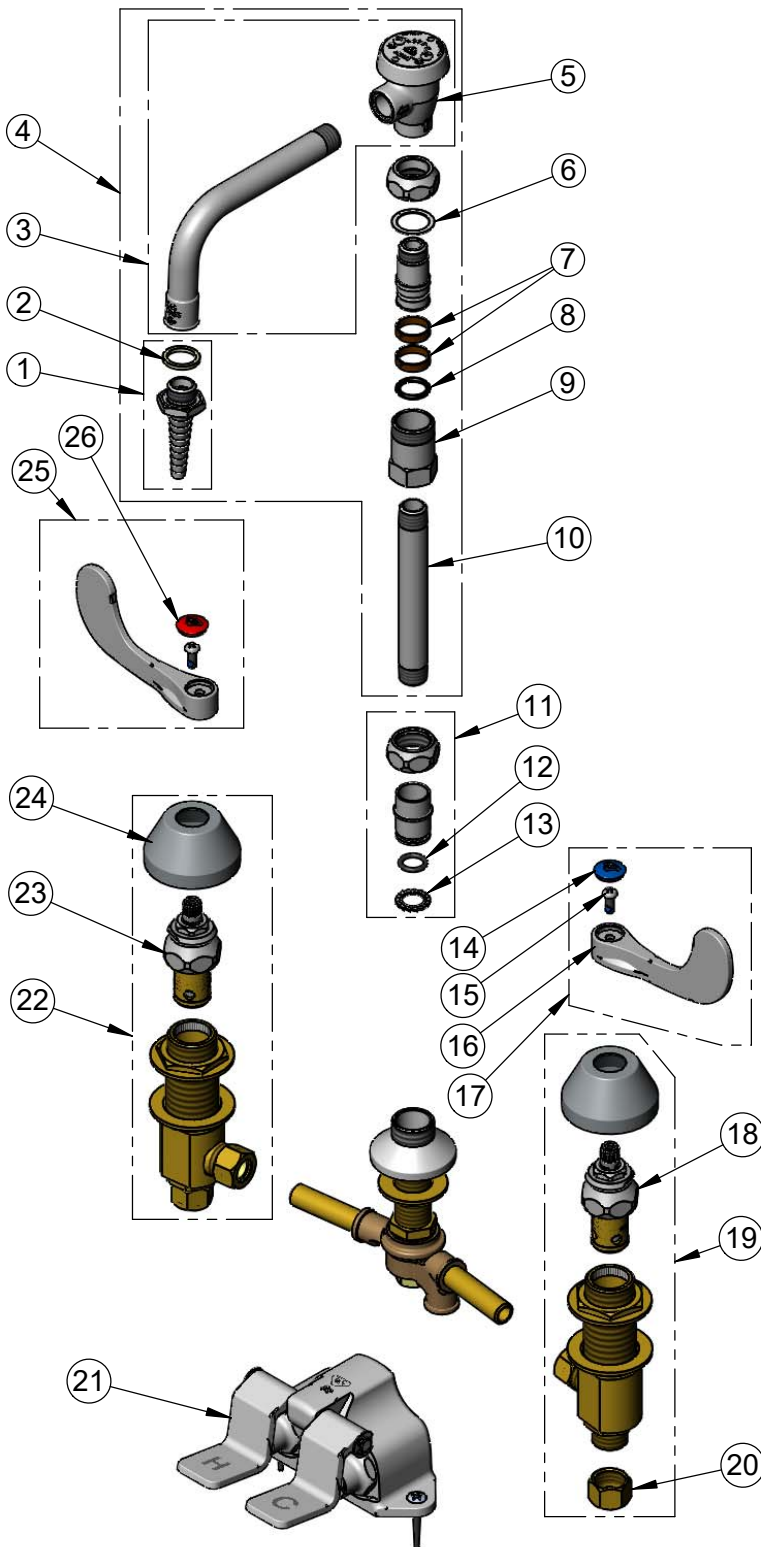

ITEM NO.	SALES NO.	DESCRIPTION
1	B-0198	Serrated Tip w/ Washer
2	001051-45	Washer
3	007283-40	Nozzle w/ Vacuum Breaker
4	BL-5560-02	Swing Nozzle w/ Vacuum Breaker & 3/8" NPT x 5" Nipple Inlet
5	B-0968	3/8" NPT Vacuum Breaker
6	009538-45	Swivel Washer
7	011429-45	Swivel Sleeves (2)
8	001074-45	O-Ring
9	054X	Swivel Body
10	000361-40	Nipple, 3/8" NPT x 5"
11	EZ-K	EasyInstall Kit
12	006562-45	O-ring
13	014200-45	Star Washer, Anti-Rotation
14	018506-19NS	Blue Button Index, Press-in
15	000925-45	Lab Handle Screw
16	B-WH4-NS	Wrist Action Handle - New Style
17	B-WH4C-NS	4" Wrist Action Handle, Blue Index & Screw
18	006477-40NS	CWS Quarter-Turn Eterna Cartridge w/ Spring Check, LTC
19	161A-NS	B-0850 Side Body - Cold
20	000958-20	Coupling Nut
21	B-0502	Double Pedal Valve Body
22	162A-NS	B-0850 Side Body - Hot
23	006478-40NS	CWS Quarter-Turn Eterna Cartridge w/ Spring Check, RTC
24	001257-40NS	Bell Escutcheon
25	B-WH4H-NS	4" Wrist Action Handle, Red Index & Screw
26	001193-19NS	Red Button Index, Press-in

Product Specifications:

8" Concealed Widespread Mixing Faucet, Quarter-Turn Eterna Cartridges w/ Spring Checks, 4" Wrist Action Handles, Swing Nozzle w/ Vacuum Breaker, Pedal Valve Connection w/ Floor Mounted Double Pedal Valve & 1/2" NPT Male Inlets w/ Coupling Nuts

Product Compliance:

ASME A112.18.1 / CSA B125.1
NSF 61 - Section 9
NSF 372 (Low Lead Content)
ASSE 1001 (VB)
ANSI A117.1 (ADA)