



T&S BRASS AND BRONZE WORKS, INC.

2 Saddleback Cove / P.O. Box 1088
Travelers Rest, SC 29690

Model No.

B-0153

Item No.

Travelers Rest, SC: 800-476-4103 • Simi Valley, CA: 800-423-0150 • Fax: 864-834-3518 • www.tsbrass.com

This Space for Architect/Engineer Approval

Job Name _____ Date _____

Model Specified _____ Quantity _____

Customer/Wholesaler _____

Contractor _____

Architect/Engineer _____



B-0502
Double Pedal
Valve w/ 1/2"
NPT CW-HW
Inlets & Outlet



B-0044-H
44" Stainless
Steel Flex Hose
w/ Polyurethane
Inner Hose

001AS
1.15 GPM
Gray Spray Head



Finger Hook



3/8" NPT x 24"

Ø 1 11/16"
[43mm]
Rigid Deck Flange

150A
Tailpiece & Nut
Furnished for
Optional 1/4" NPT
Connection

10 15/16"
[277mm]

14 11/16"
[374mm]

Mounting Surface

38 7/8"
[988mm]

1 1/8"
[29mm]
Maximum
Thickness

Piping Supplied
By Customer

Rough-In Requirement:
Ø 1" [25mm] Mounting Hole

Product Specifications:
Rigid Pre-Rinse Double Pedal Valve & Spray Attachment

Product Compliance:
ASME A112.18.1 / CSA B125.1
NSF 61 - Section 9
NSF 372 (Low Lead Content)



T&S BRASS AND BRONZE WORKS, INC.
 2 Saddleback Cove / P.O. Box 1088
 Travelers Rest, SC 29690

Model No.
B-0153

Item No.

Travelers Rest, SC: 800-476-4103 • Simi Valley, CA: 800-423-0150 • Fax: 864-834-3518 • www.tsbrass.com

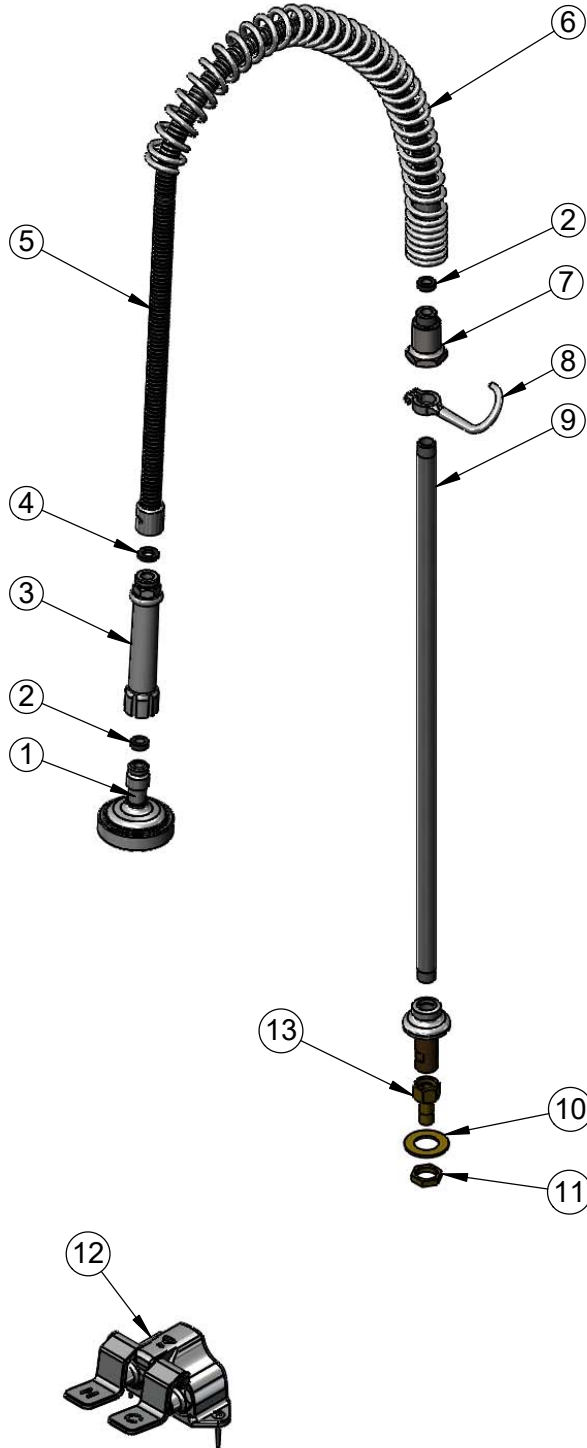

ITEM NO.	SALES NO.	DESCRIPTION
1	001AS	1.15 GPM Spray Head
2	010476-45	#27 Washer
3	002987-40	Flex Hose Handle Grip
4	001014-45	Washer, B-0100 Hose Barrel
5	B-0044-H2A	Flexible Stainless Steel Hose - Less Handle
6	000888-45	EasyInstall Overhead Spring
7	000821-40	Spring Body
8	004R	Finger Hook
9	000372-40	3/8" NPT x 24" Riser
10	000999-45	Brass Lock Washer
11	002954-45	Shank Lock Nut
12	B-0502	Double Pedal Valve
13	150A	1/4" NPT Tailpiece & Nut

Product Specifications:
 Rigid Pre-Rinse Double Pedal Valve & Spray Attachment

Product Compliance:
 ASME A112.18.1 / CSA B125.1
 NSF 61 - Section 9
 NSF 372 (Low Lead Content)