

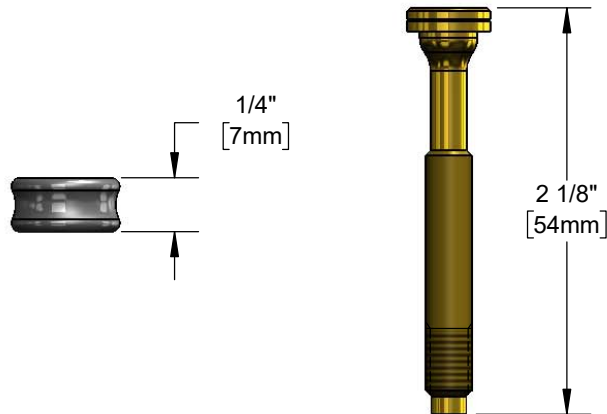

Architect/Engineering Specifications:

9/16" rubber packing seal and 2 1/8" brass squeeze valve stem for T&S spray valves. Certified to NSF 61 - Section 9 and NSF 372.

Job Name _____
 Model Specified _____ Quantity _____
 Variations Specified _____
 Date _____



Features & Benefits:

- Rubber packing seal for T&S spray valves
- Brass squeeze valve stem for T&S spray valves
- Materials: Rubber, Brass

Product Compliance:

- NSF 61 - Section 9
- NSF 372 (Low Lead Content)



Warranty: One Year (Limited)



Performance Data:

- N/A

