

Bath / shower mixing valve



Sales reference:

6508S : BATH / SHOWER MIXING VALVE ON COLUMN WITH HOSE AND HAND SHOWER - HARD WATER PROTECTION (available only chrome plated)

Cartridge reference

06599/35: ceramic cartridge 1" 1/8 with temperature stop



This product is delivered, carrying position, spout position lyied.

To restore the spout into operating position

- *Unscrew the cone point screw which is behind the spout*
- *Turn the spout in use position*
- *Tighten the cone point screw*

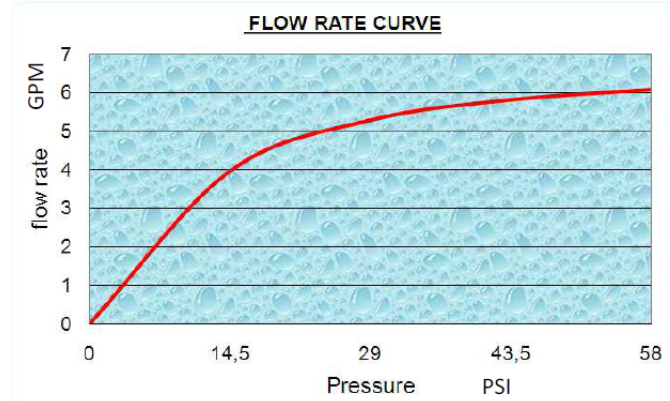
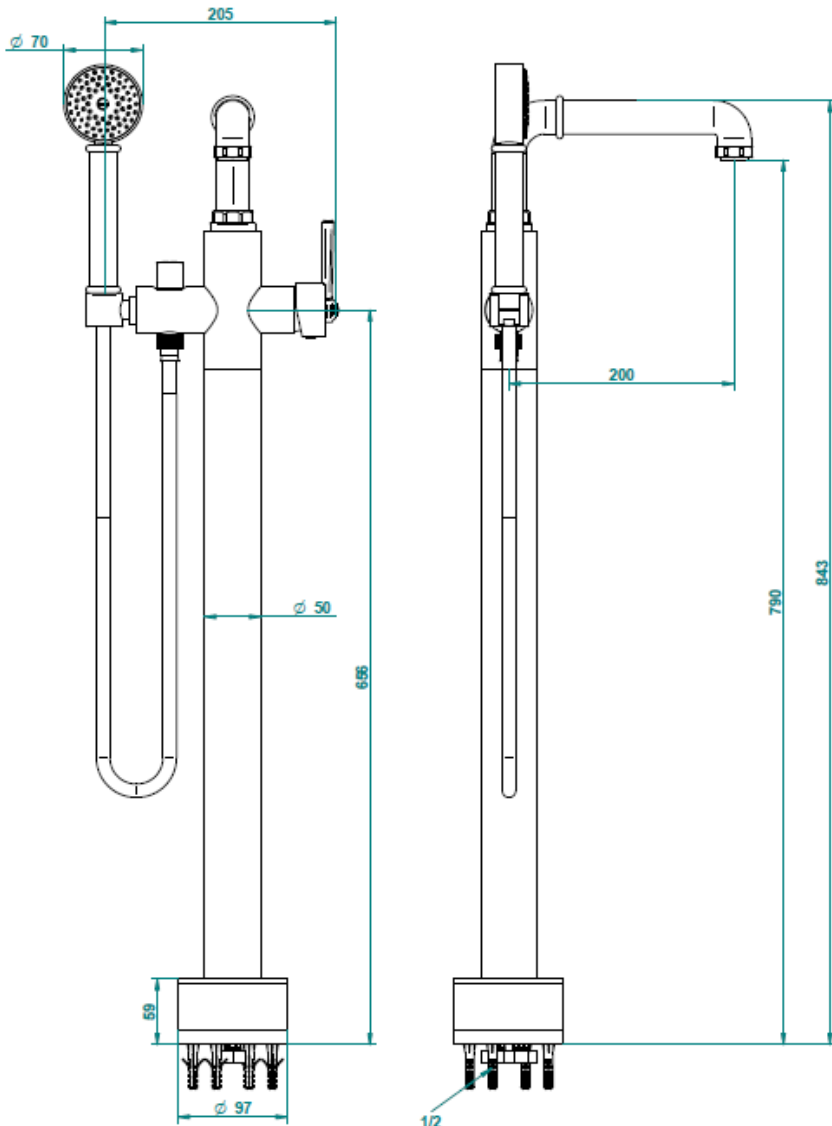

The inlets must be low to the ground. They can be hidden by the floor fixing piece.

Installation

Put the part in position in order the part which will be fix in the floor is correctly placed.



This product is delivered assembled.

- Dismount the set.
- Lift the cap- Unscrew the 4 screws
- which assemble the column of the base.

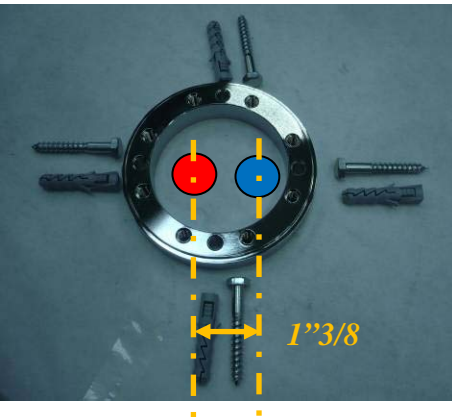

Fix the base with the 4 coach screws + pin (the pins supplied are for a full floor)

The distance between the water inlets must be centered from the base to be able to screw the hose without problem.

The inlets must be low to the ground. They must be hidden by the floor fixing piece.

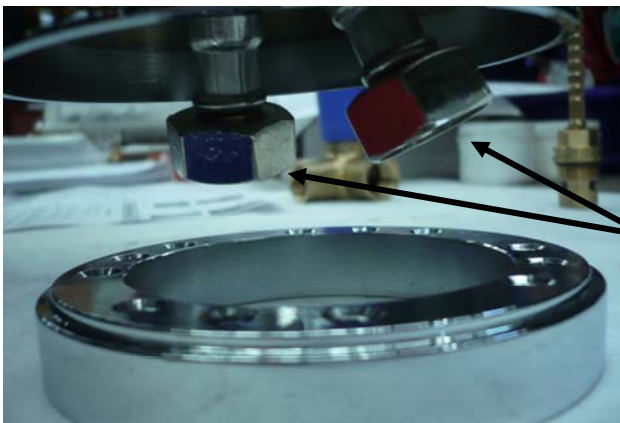
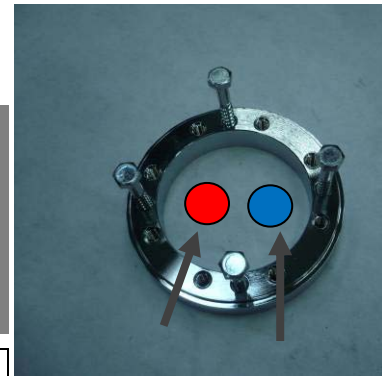

Position the set : the handle on the right and the hand shower on the left.

Connect the supply hoses with the water supply Caution : check the tightness.

lock the 4 screws.



- Slide the cover plaque until contact.
- Place the spout in position.
- lock the holding cone point screw

Removing of the spout



*To remove the spout,
Slide the setting up,
Unscrew the needle screw.*



WARRANTY, CLEANING AND MAINTENANCE

WARRANTY

5 years general Warranty :Valves, fitting and our chrome finish

All other finishes are Warranted For **1 year** claims are accepted after analyze.

- ☞ Installations must be carried out by professional plumbers / contractors and in accordance with the code of practice and standards in line with DTU.
- ☞ Products must be used and maintained in accordance with their purpose and in line with manufacturers instructions.
- ☞ Product must be regularly maintained and must include regular cleaning out of aerators and filters. Where necessary systems should be de-scaled to reduce the damaging effects of hard water calcium build up which are beyond the control of the manufacturer.
- ☞ Cleaning must be undertaken with non-abrasive and non-corrosive products and cloths.

WARRANTY EXCLUSIONS

- ☞ Normal wear and tear of working parts to include diverters, ceramic heads, spindle heads, ceramic or thermostatic cartridges.
- ☞ Frost damage
- ☞ Accidental impact
- ☞ Use of corrosive or abrasive products which includes marble cleaners.
- ☞ Damage from particles of dirt, etc caused by lack of cleaning of aerators or filters.
- ☞ Incorrect installation. Damage to products caused by installation or dismantling.

AFTER-SALES SERVICE FOR DEFECTIVE PRODUCT

- ☞ Defective items must be returned to the factory at the clients expense and addressed to the THG After Sales Department. We recommend that returned items are correctly insured during transit.
- ☞ Product must be carefully wrapped by the returnee, with each item individually protected to prevent any impact during delivery. We recommend a digital image be taken of the wrapped goods to confirm their packing.
- ☞ Upon receipt of the returned items goods will be inspected by THG Quality Control and a report will be prepared. Such report will determine if the alleged fault/damage is a result of the manufacturer.

All our products are checked for water tightness. In order to maintain the warranties it is necessary to regularly drain through water systems to ensure the prevention of dirt damage to the ceramic heads and cartridges and thermostatic cartridges.

Goods found NOT to be defective will be repaired or changed at full charge to the client.

CLEANING

To maintain fittings in perfect condition cleaning is recommended after every use with soapy water applied, rinsed and then dried off with a soft, non-abrasive cloth.



Abrasive products which contain alcohol, acid or anti-scale ingredients are prohibited and will nullify the Warranty.

For a deeper clean and to remove residual or corrosive markings we recommend a monthly application of a suitable cleaner for the metal installed or we offer the following recommended cleaning products:



▶ **Renov'rob** (sale references :140R et 140MR)

For use on CHROME and NICKEL finishes this wax and organic soap based cleaner, applied and removed with a non-abrasive soft cloth, creates a protective wax-film which enables the fittings to be polished and produces a lasting brightness.

▶ **Brillor** (sale references :140B et 140MB)

For use on GOLD, LUXBRASS and SATIN finishes this fatty-acid soap and micro-granules of organic content, applied and removed with a non-abrasive soft cloth, creates a protective wax film which enables the fittings to be polished and produces a lasting brightness. (satin Finishes should be lightly buffed).

It is possible to order aerators (look at our brochure)



CLEANING OF THE HAND- SHOWER AND HEAD - SHOWER



These should be removed each 6-8 weeks and soaked in the same solution (8 parts water – 1 part white vinegar) For handshowers which are not equipped with hard-water protection, we recommend you to do a regular cleaning in water with some white vinegar.

