

KNIGHT

COMMERCIAL LOCKS
LEVERSET
BUILDER PACK



ENTRY
ENTRANCE/OFFICE
INSIDE TURN BUTTON



PRIVACY
RESTROOM
INSIDE PUSH BUTTON



PASSAGE
HALL/CLOSET



STOREROOM



CLASSROOM

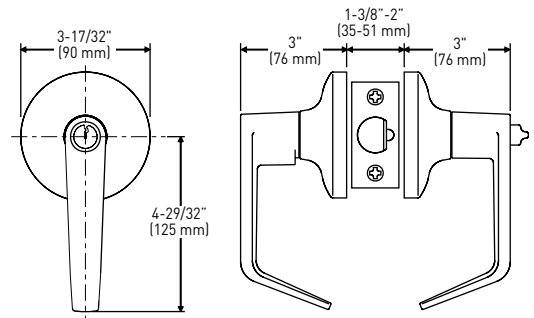

AVAILABLE FINISH

26D
SATIN
CHROME



FEATURES

- ANSI/BHMA 156.2 GRADE 1
- MAXIMUM DUTY CYLINDRICAL CONSTRUCTION
- UL LISTED FOR 3-HOUR FIRE RATING
- CLUTCH MECHANISM* ON ALL LOCKING FUNCTIONS
- SC4 6-PIN KEYWAY STANDARD - (WR5 OPTIONAL)
- FIXED BACKSET 2-3/4"
- 1-1/8" x 2-1/4" SQUARE MORTISE LATCH
- FITS DOORS 1-3/8" (35 mm) - 2" (51 mm) THICK
- SUPPLIED WITH ASA STRIKE - STANDARD
- 10 YEAR MECHANICAL WARRANTY

KNIGHT LEVERSET - BUILDER PACK
GRADE 1 CYLINDRICAL

		26D SATIN CHROME	CASE PACK
ENTRY - ENTRANCE/OFFICE LEVERSET (INSIDE TURN BUTTON)	*CLUTCH MECHANISM	32-6953	10
PRIVACY - RESTROOM LEVERSET (INSIDE PUSH BUTTON)	*CLUTCH MECHANISM	32-6940	10
PASSAGE - HALL/CLOSET LEVERSET		32-6910	10
STOREROOM	*CLUTCH MECHANISM	32-6980	10
CLASSROOM	*CLUTCH MECHANISM	32-6970	10