

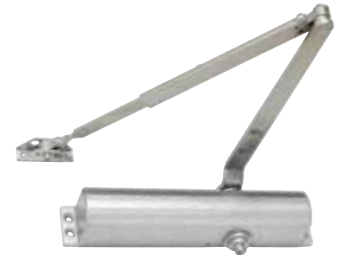

DOOR CLOSERS

1900 SERIES

GRADE 1
BUILDER PACK



WITHOUT PLASTIC COVER

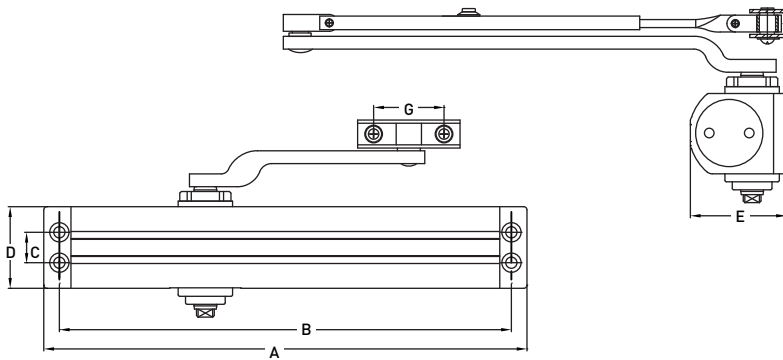









FEATURES

- UL LISTED - UL10C COMPLIANT UL10C FOR POSITIVE PRESSURE
- ANSI A 156.4 - GRADE 1
- POWER ADJUSTABLE 1-6
- STANDARD BARRIER FREE OPERATION (COMPLIES WITH ADA)
- STANDARD BACKCHECK, STANDARD SWEEP AND LATCHING SPEED
- STANDARD DELAYED ACTION ON 13-1900BFDAAL MODEL
- NON-HANDED INSTALLATION
- CAST ALUMINUM BODY
- HIGH GRADE QUALITY PLASTIC COVER
- UNIVERSAL MOUNTING FOR REGULAR, TOP JAMB AND PARALLEL ARM APPLICATIONS
- RACK AND PINION MECHANISM
- 10 YEAR MECHANICAL AND 1 YEAR FINISH WARRANTY

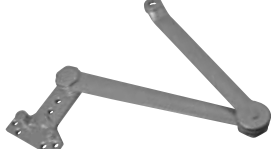
	A	B	C	D	E	F
13-1900AL	11-7/8" (302mm)	11-1/8" (282.5mm)	3/4" (19mm)	2" (51mm)	2-3/8" (60mm)	1-3/4" (44mm)

1900 SERIES DOOR CLOSER - BUILDER PACK	MAXIMUM RECOMMENDED DOOR SIZE & WEIGHT		ALUMINUM	CASE PACK
	ADJUSTABLE POWER 1 THROUGH 6 WITH STANDARD BACKCHECK AND BARRIER FREE	48" x 96" - (121cm x 243cm)	266 lbs - (121 kg)	13-1900AL
ADJUSTABLE POWER 1 THROUGH 6 WITH STANDARD BACKCHECK, BARRIER FREE AND DELAYED ACTION	48" x 96" - (121cm x 243cm)	266 lbs - (121 kg)	13-1900BFDAAL	6

1900 SERIES DOOR CLOSER ACCESSORIES	DESCRIPTION	ALUMINUM	CASE PACK
	REGULAR OR TOP JAMB NARROW DROP PLATE - 2" TALL (51 mm)	13-A1900DP51AL	10
	PARALLEL ARM DROP PLATE - 3-9/16" TALL (90 mm)	13-A1900DP90AL	10
	PARALLEL ARM BRACKET FOR FRICTION HOLD OPEN ARM	13-A1900PAFHOAL	10
	PARALLEL ARM BRACKET	13-A1900PABAL	10
	FRICTION TYPE - HOLD OPEN ARM MAXIMUM DOOR WEIGHT: 60 KG (132 LBS)	13-A1900FHOAL	10
	CUSH STOP ARM	13-A1900CSAAL	10
	CUSH STOP HOLD OPEN ARM MAXIMUM DOOR WEIGHT: 60 KG (132 LBS)	13-A1900CSHOAAL	10
	EXTENDED LONG ROD AND SHOE	13-A1900ELRSAL	50
	THRU BOLTS	13-A1900SNBAL	10
	SCREW PACK	13-A1900SPAL	10