

IMPORTANT document includes template must print at 100%

Taymor

INSTALLATION INSTRUCTIONS F9700 SERIES FIRE-RATED SURFACE VERTICAL ROD EXIT DEVICE

MAIN CHASSIS & TOP AND BOTTOM LATCHES MOUNTING SCREWS

- For steel prepared doors, drill/tap and use supplied machine screws.
- For thin gauge metal, non-prepared doors or for labeled wood doors use thru bolts.
- See template for details on mounting screws.

DOOR HANDING GUIDE:

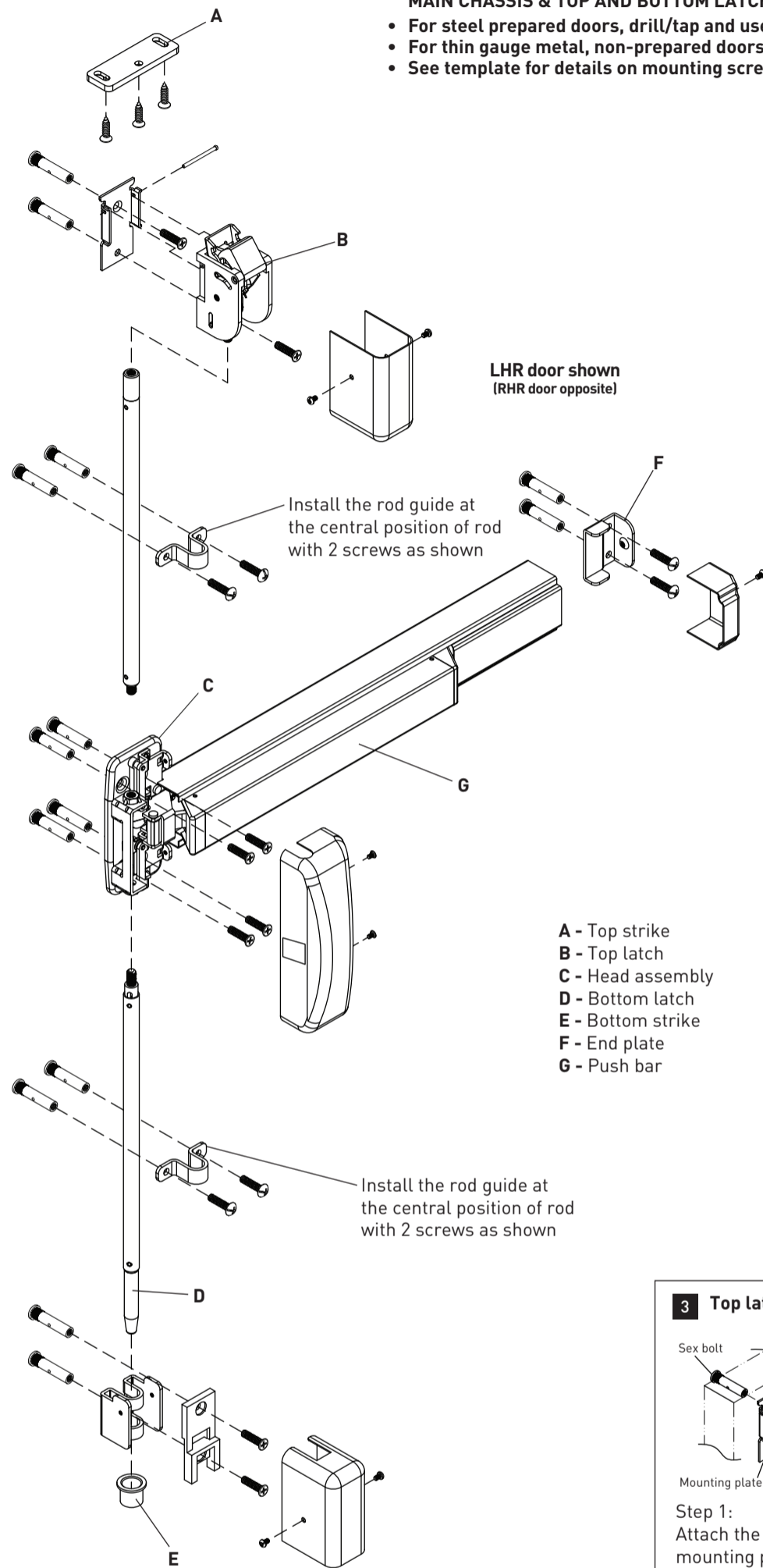
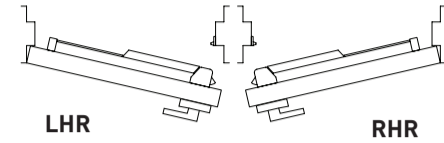

- A - Top strike
- B - Top latch
- C - Head assembly
- D - Bottom latch
- E - Bottom strike
- F - End plate
- G - Push bar

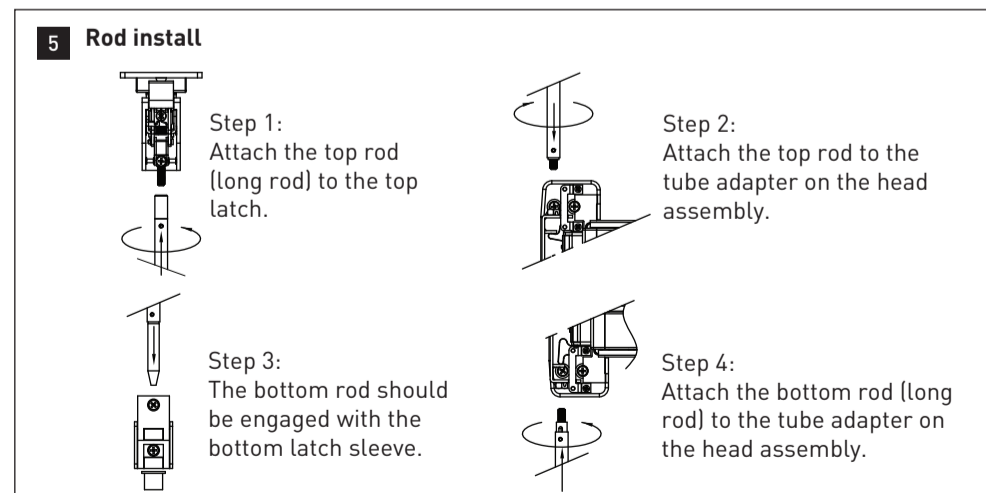
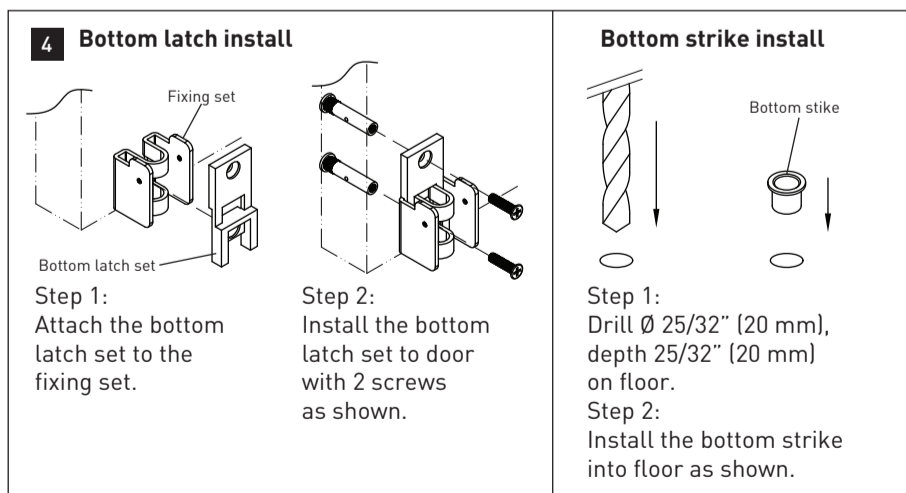
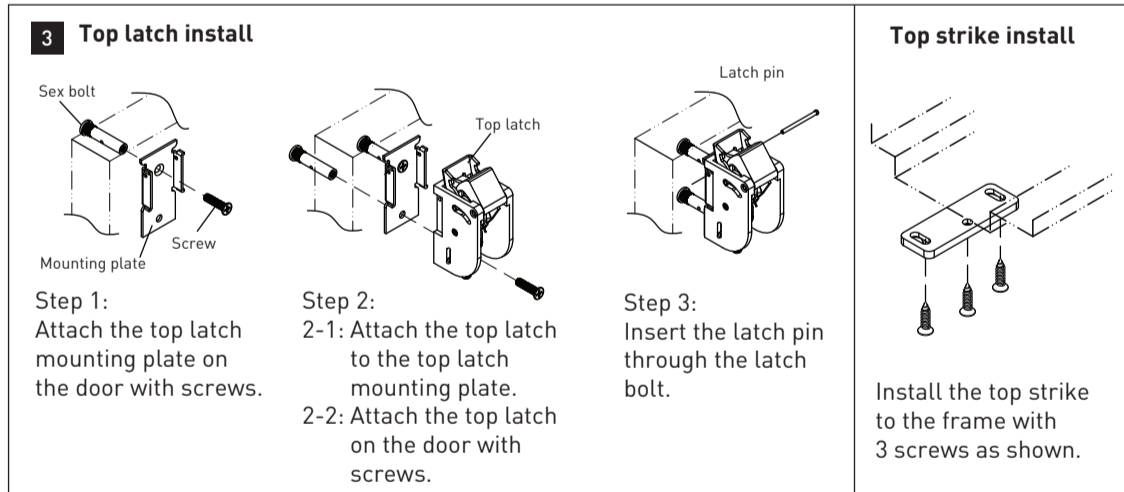
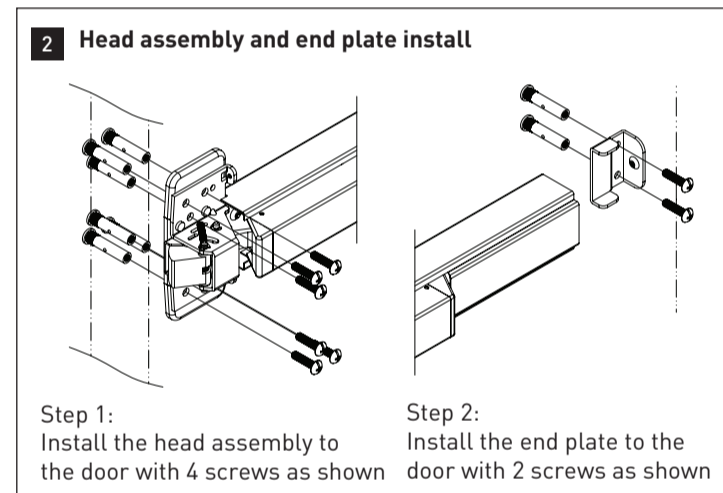
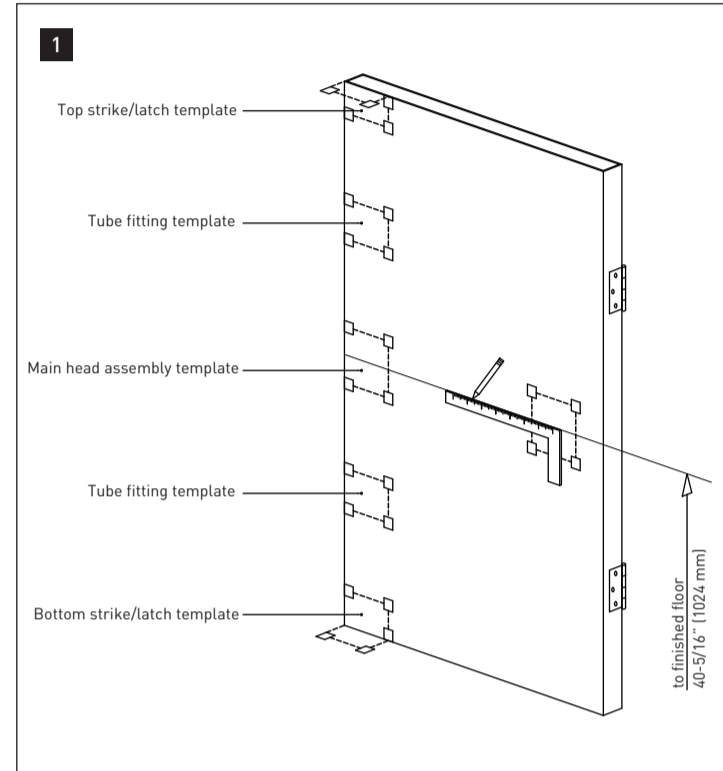

CUSTOMER SERVICE
WEST 1-800-267-4774 | EAST 1-800-387-7064 | taymor.com

© REGISTERED TRADEMARK OF TAYMOR INDUSTRIES LTD.
January 2013

IMPORTANT

document includes template must print at 100%

Taymor

TEMPLATE
F9700 SERIES FIRE-RATED SURFACE VERTICAL ROD EXIT DEVICE

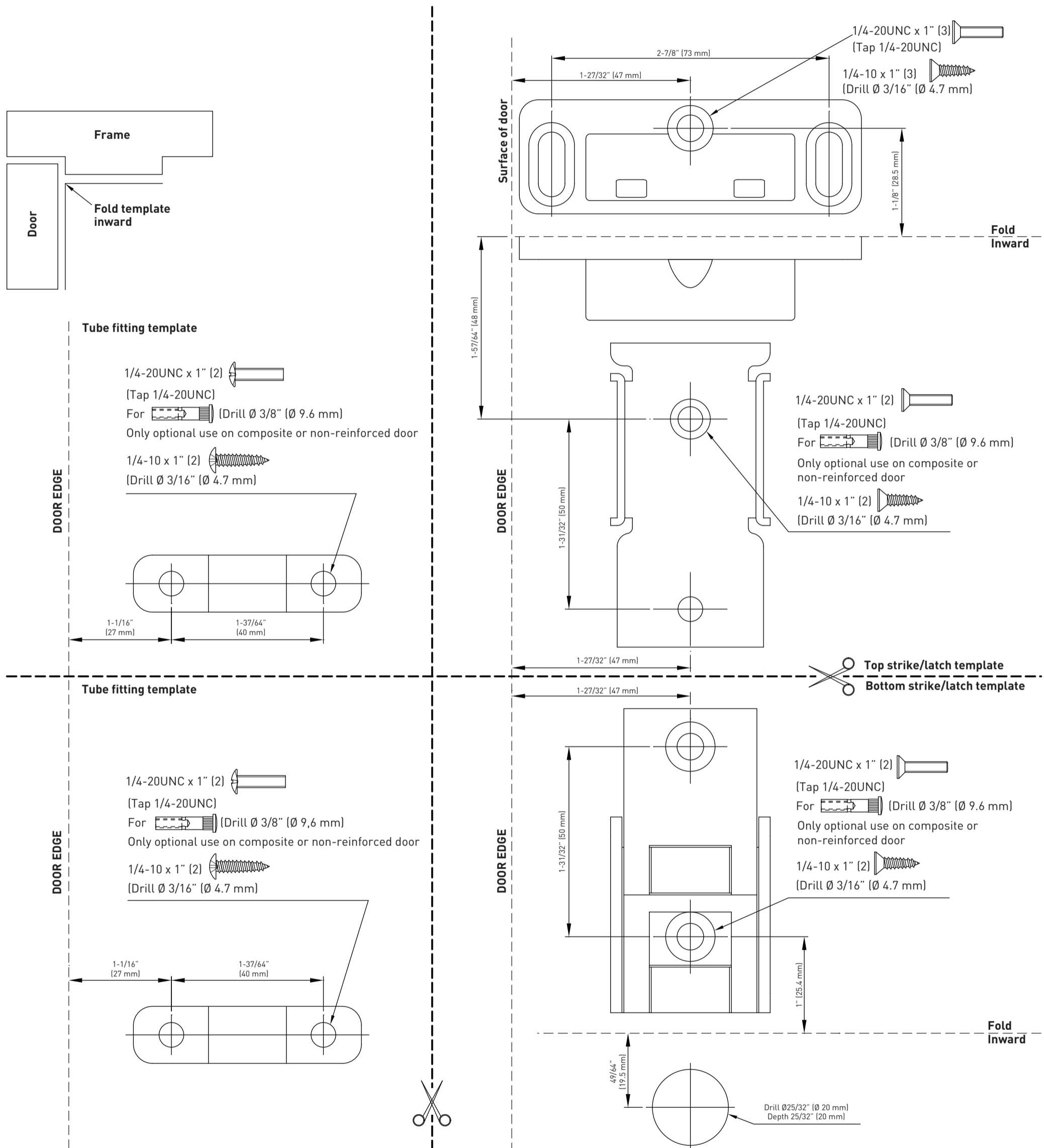

CUSTOMER SERVICE
WEST 1-800-267-4774 | EAST 1-800-387-7064 | taymor.com

© REGISTERED TRADEMARK OF TAYMOR INDUSTRIES LTD.

January 2013

IMPORTANT document includes template must print at 100%



**TEMPLATE
F9700 SERIES FIRE-RATED SURFACE VERTICAL ROD EXIT DEVICE**

Main chassis template

