

Location:



SYMMONS® Water Dance™

Shower Valve 1-6320-X Specification Submittal

Feature Highlights

- Symmons Shower Valve with lever handle
- Symmons High-Flo pressure-balancing mixing valve with integral service stops and adjustable stop screw to limit handle turn
- Polished chrome finish

Model Numbers

- 1-6320-X
Shower Valve System with Symmons High-Flo pressure-balancing mixing valve p/n HF-115-X
- 1-6320-X-CHKS
Shower Valve System with Symmons High-Flo pressure-balancing mixing valve p/n HF-115-X-CHKS
- 1-6320-TRM
Trim only, mixing valve ordered separately
- HF-115-X
Symmons High-Flo mixing valve without trim. Valve includes integral service stops to allow water shut-off for service
- HF-115-X-CHKS
Symmons High-Flo mixing valve without trim. Valve includes integral check stops to allow water shut-off for service

Finish Options / Modifications

Append appropriate -suffix to model number

- STN Satin nickel

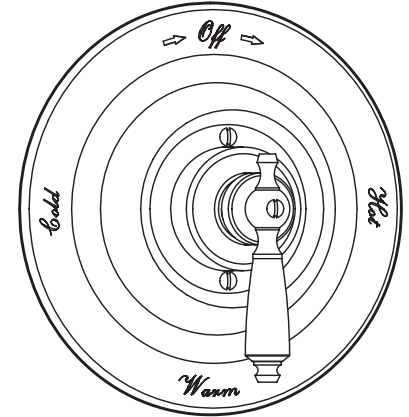

Standards / Certifications

ASME A112.18.1/CSA B125.1



Warranty

- Limited Lifetime - to the original end purchaser in consumer installations
- 5 years - for commercial installations

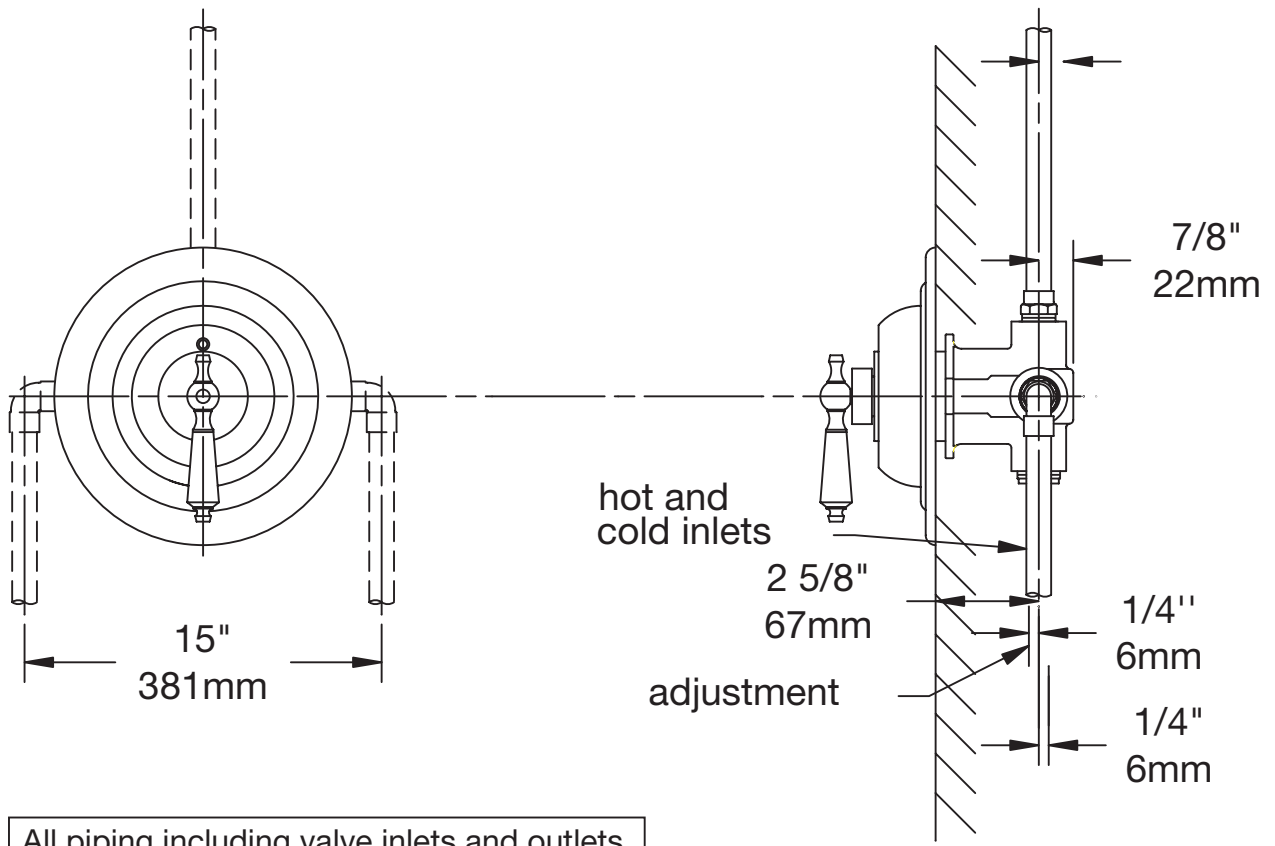

All piping including valve inlets and outlets
3/4" except where noted otherwise.