



Location:

SYMMONS® DS Creations

the smart choice™



0630-3605-YSB-TRM (CD0630-3605-YSB-TRM)

Shower/Hand Shower Trim

Specification Submittal

Model Numbers	Specification
<input type="checkbox"/> 0630-3605-YSB-TRM <i>Shower/Hand Shower Trim</i>	Shower/Hand Shower Trim shall include metal lever handle, 30" metal slide bar, separate dual outlet diverter trim, in-line vacuum breaker, 60" flexible metal hose, 1 mode square showerhead, 1 mode square hand shower and 2.5 gpm (9.5 L/min) flow restrictors. Shower/Hand Shower trim shall be made from metal construction, plated in standard polished chrome finish.
Warranty	Compliance
Limited Lifetime - to the original end purchaser in consumer/residential installations. 5 Years - for industrial/commercial installations. Refer to www.symmons.com/warranty for complete warranty information.	-ASME A112.18.1/CSA B125.1 <div style="text-align: right;">  </div>

Dimensions

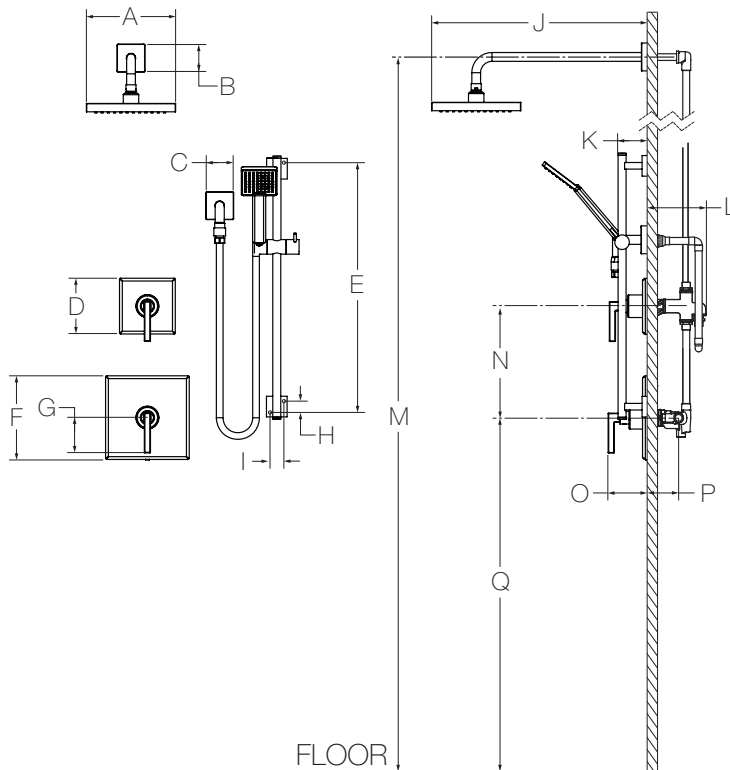

Measurements	
A	Sq. 8", 203 mm
B	Sq. 2-1/2", 64 mm
C	Sq. 2-1/2", 64 mm
D	Sq. 5", 127 mm
E	21-5/8", 549 mm
F	Sq. 7-1/2", 191 mm
G	3-1/8", 79 mm
H	13/16", 21 mm
I	1", 25 mm
J	15-5/16", 389 mm
K	2-9/16", 65 mm
L	4-7/8", 124 mm
M	Ref. 77", 1956 mm
N	10", 254 mm
O	3-7/16", 87 mm
P	Rough-in 2-3/8" ± 1/2", 60 mm ± 13 mm
Q	Ref. 42", 1067 mm

Notes:

- 1) All dimensions measured from nominal rough-in (see P as reference).
- 2) Dimensions subject to change without notice.