



Location:



0368-2HSB-LHS
Hand Shower Unit
Specification Submittal

Model Number	Specification
<input type="checkbox"/> 0368-2HSB-LHS <i>Hand Shower Unit</i>	Hand shower unit features wall elbow, 30" slide bar, 60" flexible metal hose and cradle for hand shower mounting. Components made from metal and nonmetallic materials plated in standard polished chrome finish.
Warranty	
<p>Limited Lifetime - to the original end purchaser in consumer installations. 5 Years - for commercial installations.</p> <p>Refer to www.symmons.com/warranty for complete warranty information.</p>	

Dimensions

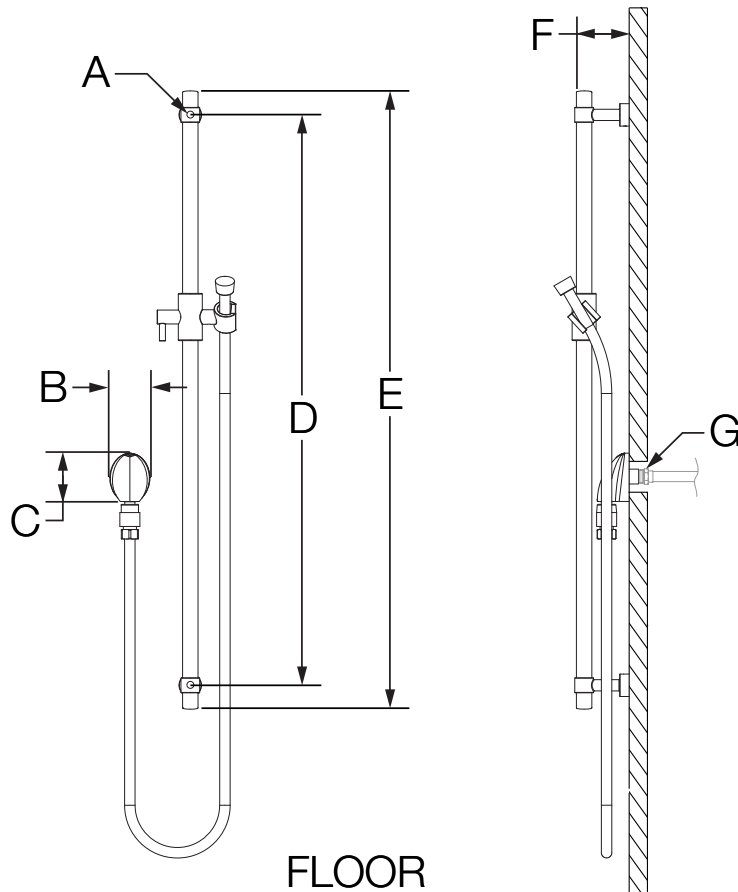

Measurements	
A	(2x) Hole Size Ø 5/16", 8 mm
B	2-1/8", 54 mm
C	2-5/8", 67 mm
D	30", 762 mm
E	32-1/2", 826 mm
F	2-7/8", 73 mm
G	Male 1/2" NPSM thread must be recessed 1/4" (6mm) from finished wall

Note: Dimensions subject to change without notice.



0368-2HSB-LHS

Unité de douchette à main

Présentation des spécifications

Numéro de modèle	Spécifications
<input type="checkbox"/> 0368-2HSB-LHS <i>Unité de douchette à main</i>	L'unité de douchette à main comprend un coude mural, une barre à glissière de 30 po, tuyau métallique flexible 60 po et un support pour le montage de la douchette. Composants en matériaux métalliques et non métalliques au fini chrome poli standard.
Garantie	
<p>Garantie à vie limitée – à l'acheteur initial pour les installations du consommateur. 5 ans – pour des installations commerciales.</p> <p>Se reporter au site www.symmons.com/warranty pour des informations complètes concernant la garantie.</p>	

Dimensions

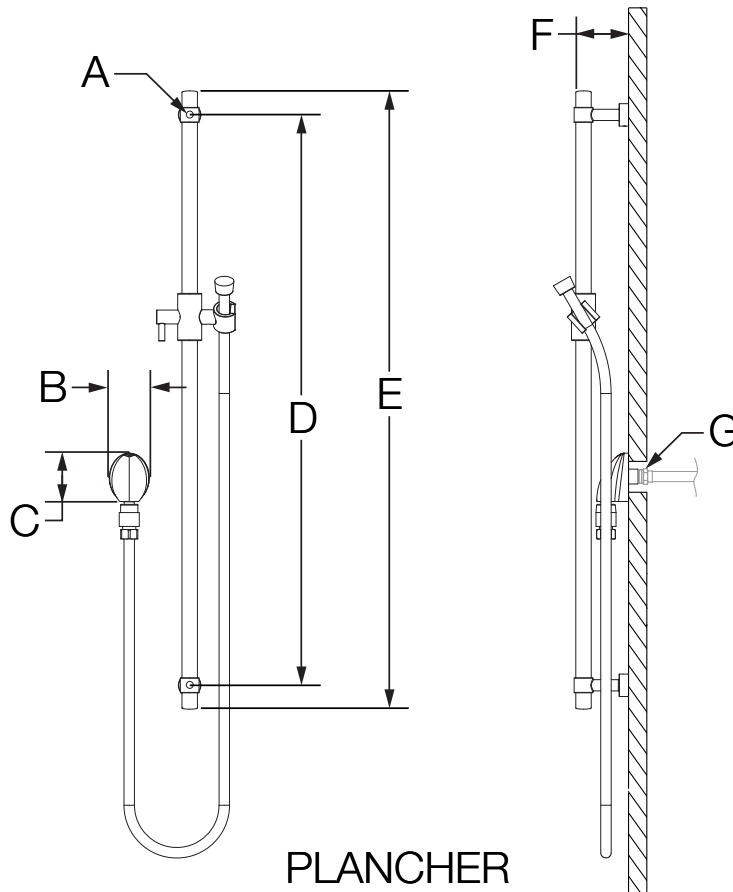

Mesures	
A	(2x) Taille du trou Ø 5/16 po, 8 mm
B	2-1/8 po, 54 mm
C	2-5/8 po, 67 mm
D	30 po, 762 mm
E	32-1/2 po, 826 mm
F	2-7/8 po, 73 mm
G	Le filetage mâle NPSM 1/2 po doit être encastré à 1/4 po (6 mm) du mur fini

Remarque : Les dimensions sont sujet à changer sans préavis.