



SYMMONS® DS Creations

the smart choice™



S0216-TRM (CDS0216-3500-TRM)

Tub/Shower Trim

Installation Guide

Model Numbers	Specification
<input type="checkbox"/> S0216-TRM <i>Tub/Shower Trim</i>	Tub/Shower Trim with secondary integral diverter shall include metal lever handle. Tub/Shower trim shall be made from metal construction, plated in standard polished chrome finish.
Warranty	
<p>Limited Lifetime - to the original end purchaser in consumer/residential installations.</p> <p>5 Years - for industrial/commercial installations.</p> <p>Refer to www.symmons.com/warranty for complete warranty information.</p>	



Dimensions

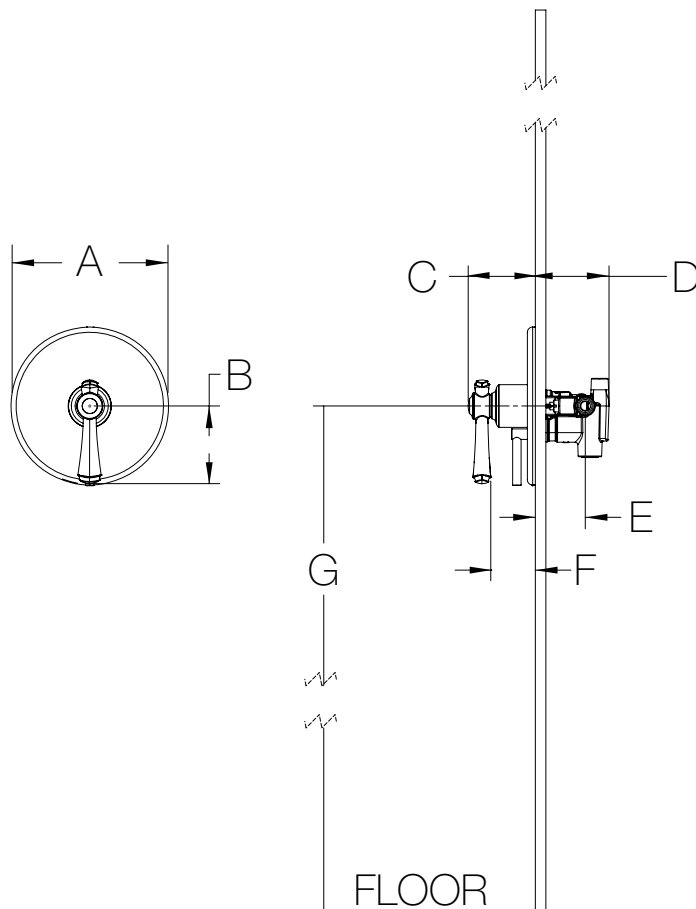

Measurements	
A	Ø 7-1/2", 191 mm
B	3-11/16", 94 mm
C	3-3/16", 81 mm
D	3-1/2", 89 mm
E	(Rough-in) 2-3/8" ± 1/2", 60 mm ± 13 mm
F	2-1/8", 54 mm
G	Ref. 42", 1067 mm

Notes:

- 1) All dimensions measured from nominal rough-in (see E as reference).
- 2) Dimensions subject to change without notice.

Parts Breakdown

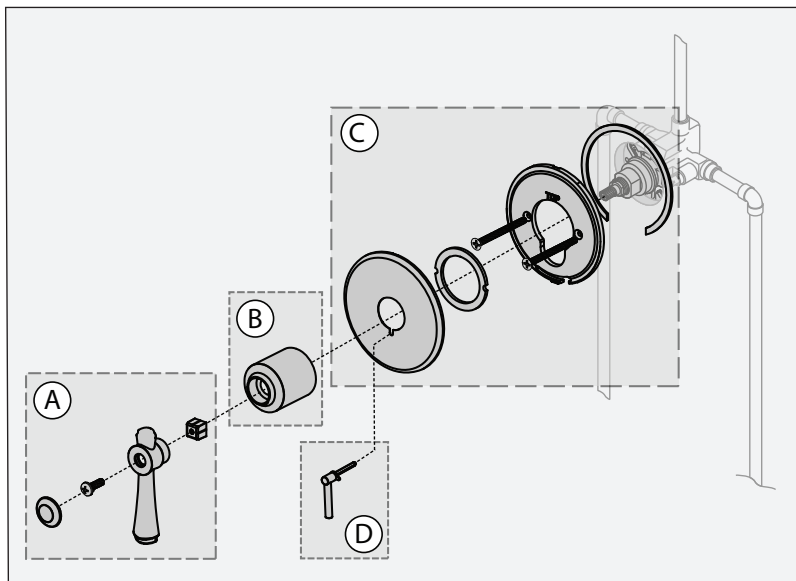

Notes:

- 1) Apply a bead of silicone around the perimeter of all shower trim installed flush to the finished wall (less mounting plates and brackets). Leave opening on bottom of escutcheon for weep hole.
- 2) Apply plumber tape to all threaded connections.

Replacement Parts

Item	Description	Part Number
A	Handle Assembly	T-694
B	Dome Cover	T-696
C	Escutcheon	RTS-058
D	Diverter Handle	FTS-013

Tools Required for Installation

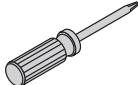
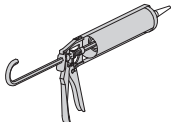
Phillips Head Screwdriver	
Silicone	

⚠ WARNING: This product can expose you to chemicals including lead, which is known to the state of California to cause cancer, birth defects, or other reproductive harm. For more information, go to www.P65Warnings.ca.gov.