







S-6606  
Tub/Shower/Hand Shower System  
**Operation & Maintenance Manual**



Model Numbers	Specification
<input type="checkbox"/> <b>S-6606</b> <i>Unity Tub/Shower/Hand Shower System</i>	<p>Shower/hand shower system powered by the Temptrol<sup>®</sup> Pressure Balancing valve. Features adjustable stop screw to limit handle turn, secondary integrated diverter control, wall cradle, separate two function diverter, non-diverter tub spout, in-line vacuum breaker, 60" flexible metal hose, 1 mode hand shower, 1 mode showerhead with easy to clean rubber nozzles and standard 2.5 gpm (9.5 L/min) flow restrictor. Components made from metal and nonmetallic materials plated in standard polished chrome finish.</p> <div style="text-align: right;">   </div>
<p><b>Modifications</b></p> <ul style="list-style-type: none"> <li><input type="checkbox"/> <b>-1.5</b>  1.5 gpm (5.7 L/min) flow restrictor</li> <li><input type="checkbox"/> <b>-2.0</b>  2.0 gpm (7.6 L/min) flow restrictor</li> <li><input type="checkbox"/> <b>-143</b> Euro-Flo three mode showerhead in place of Clear-Flo</li> <li><input type="checkbox"/> <b>-145</b> Euro-Flo five mode showerhead in place of Clear-Flo</li> <li><input type="checkbox"/> <b>-231</b> Super showerhead in place of Clear-Flo</li> <li><input type="checkbox"/> <b>-SS</b> Slip spout on any tub/shower unit</li> <li><input type="checkbox"/> <b>-X</b> Integral service stops</li> <li><input type="checkbox"/> <b>-CHKS</b> Integral check stops</li> <li><input type="checkbox"/> <b>-IPS</b> 1/2" female IPS connections</li> <li><input type="checkbox"/> <b>-REV</b> Reverse coring for back to back installations</li> <li><input type="checkbox"/> <b>-LP</b> Loop handle</li> <li><input type="checkbox"/> <b>-QD</b> Quick disconnect on hand shower units</li> <li><input type="checkbox"/> <b>-R</b> White vinyl hose in place of metal hose</li> <li><input type="checkbox"/> <b>-OP</b> 13" oval plate</li> <li><input type="checkbox"/> <b>-L/HD</b> Less showerhead</li> <li><input type="checkbox"/> <b>-72</b> 6' hose in place of 5' standard</li> <li><input type="checkbox"/> <b>-TRM</b> Trim only, valve not included</li> <li><input type="checkbox"/> <b>-STN</b> Satin Nickel finish</li> </ul>	
	<p><b>Compliance</b></p> <ul style="list-style-type: none"> <li>-ASME A112.18.1/CSA B125.1</li> <li>-WaterSense 1.5 gpm (5.7 L/min) 2.0 gpm (7.6 L/min)</li> </ul> <div style="text-align: right;">   </div> <p><u>For California Residents</u> <b>WARNING:</b> This product contains chemicals known to the State of California to cause cancer, birth defects, or other reproductive harm.</p>
	<p><b>Warranty</b></p> <p><b>Limited Lifetime</b> - to the original end purchaser in consumer/residential installations. <b>5 Years</b> - for industrial/commercial installations. Refer to <a href="http://www.symmons.com/warranty">www.symmons.com/warranty</a> for complete warranty information.</p>

**Note:** Append appropriate -suffix to model number.

## Dimensions

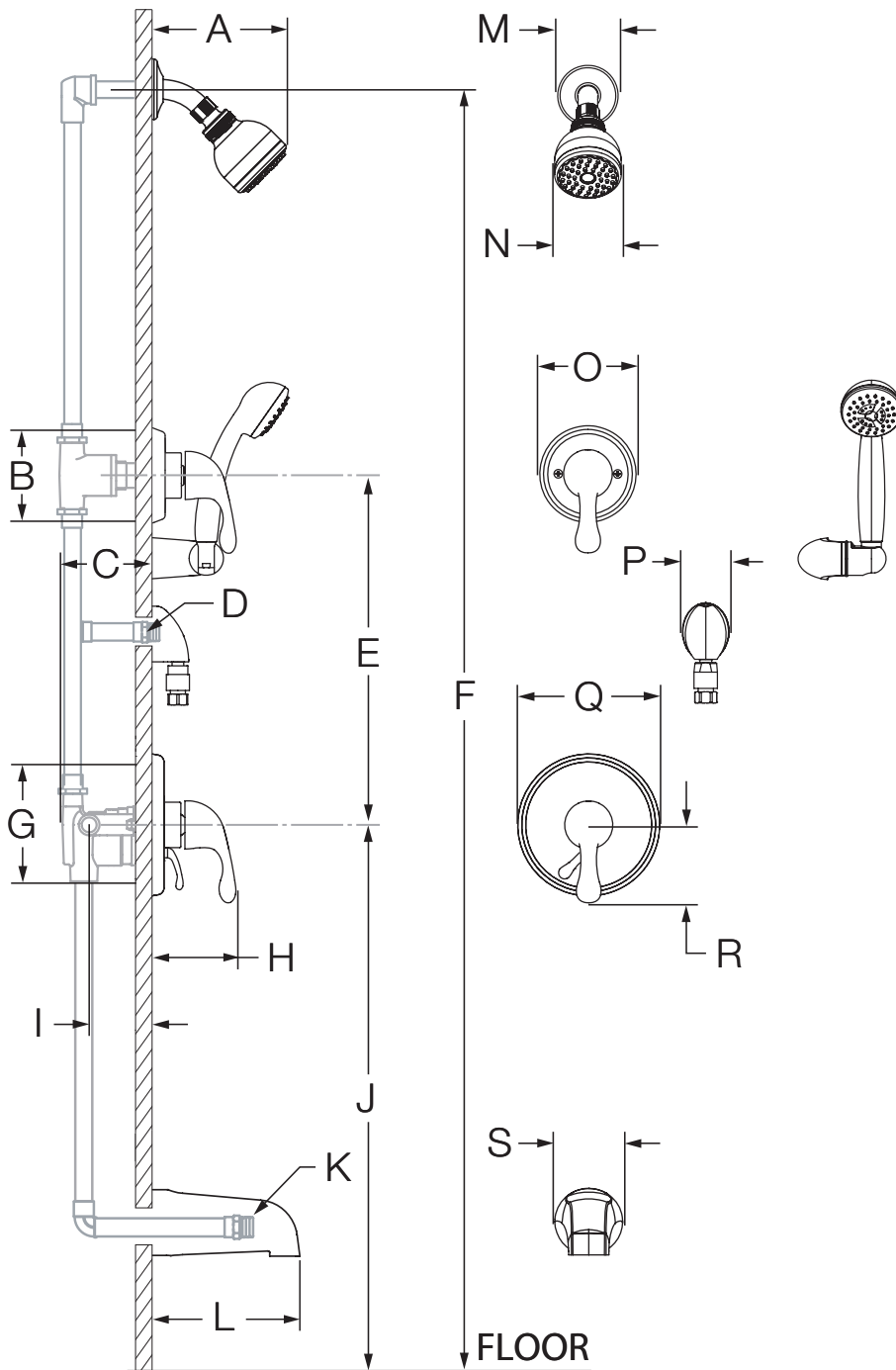

Measurements	
A	6 3/8", 162 mm
B	Diverter Valve Hole Size Min. Ø 3", 76 mm Max. Ø 3 1/4", 83 mm
C	3 1/2", 89 mm
D	Male 1/2" NPT fitting must be recessed 1/4" from finished wall
E	Ref. 10", 254 mm
F	Ref. 77", 1956 mm
G	Shower Valve Hole Size Min. Ø 3", 76 mm Max. Ø 4", 102 mm
H	3 3/4", 95 mm
I	Rough-in 2 3/8" ± 1/2", 60 mm ± 13 mm
J	Ref. 32", 813 mm
K	Male 1/2" NPT fitting must protrude 4" from finished wall
L	5 1/2", 140 mm
M	Ø 2 1/2", 64 mm
N	Ø 2 3/4", 70 mm
O	Ø 4 1/4", 108 mm
P	2 1/8", 54 mm
Q	Ø 6 3/8", 162 mm
R	3 1/2", 89 mm
S	Ø 2 1/2", 64 mm

### Notes:

- 1) All dimensions measured from nominal rough-in (see I as reference).
- 2) Dimensions subject to change without notice.

## Parts Breakdown

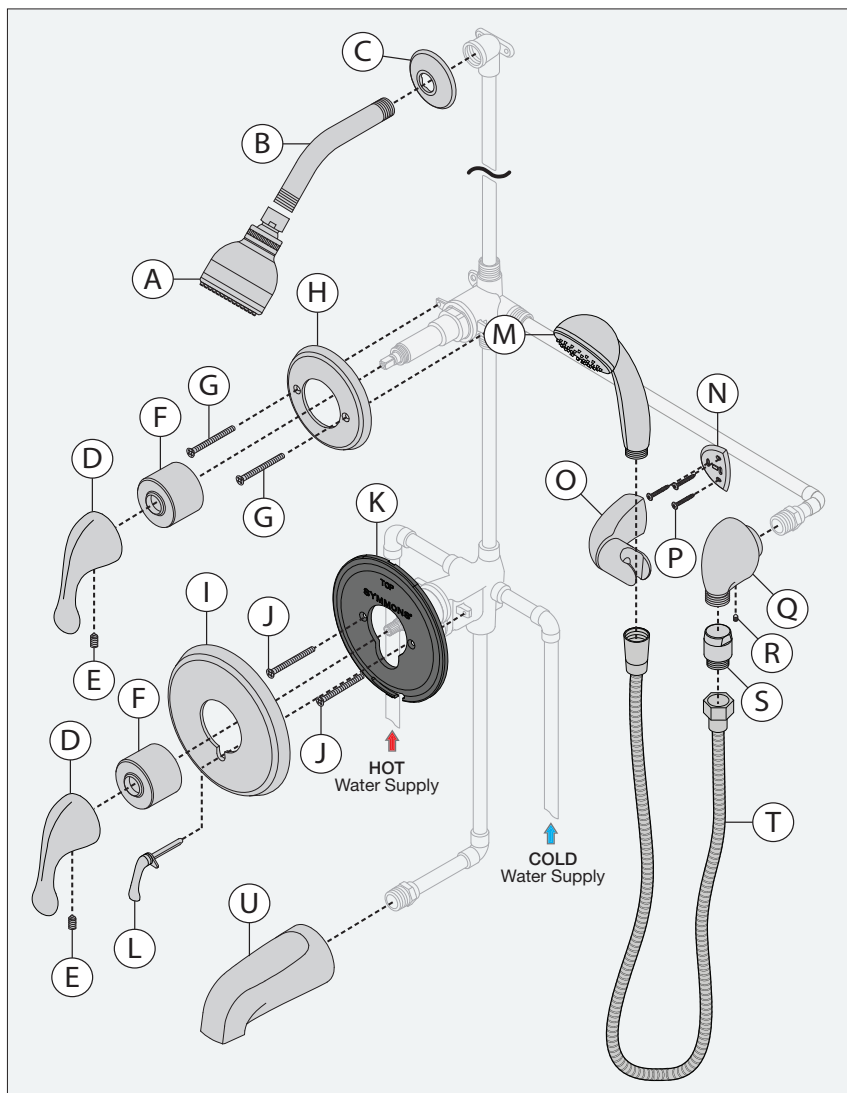

### Notes:





- 1) Apply a bead of silicone around the perimeter of all shower trim installed flush to the finished wall. Leave opening on bottom of escutcheons for weep hole.
- 2) Apply plumber tape to all threaded connections.

### Replacement Parts

Item	Description	Part Number
A	Showerhead	4-141*
B C	Shower Arm & Flange	300S*
D E	Shower or Diverter Handle Assembly	RTS-064*
F	Dome Cover	T-19*
G H	Diverter Escutcheon Kit	96-66-DIV-ESC*
I J K	Shower Escutcheon Kit	S-6600TS-ESC*
L	Secondary Integrated Diverter Handle	RTS-066*
M	Hand Shower	EF-100*
N O P	Wall Cradle	EF-106*
Q R	Wall Ell	EF-105*
S T	In-line Vacuum Breaker & 60" Hose	SP-4*
U	Tub Spout	060

\*Note: Append -STN to part number for Satin Nickel finish.

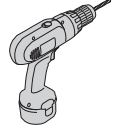
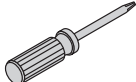
### Tools Required

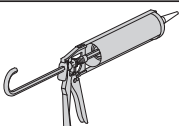
Adjustable wrench	
Allen wrench (1/8")	
Drill	
Phillips head screwdriver	
Plumber tape	
Silicone	

## Installation

### Note:

For valve body installation, please see valve body manuals.

- 1) Install mounting plate (K) to shower valve. Secure with two screws (J).

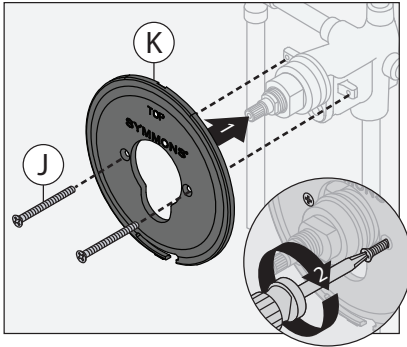

- 2) Install secondary integrated diverter handle (L) to shower escutcheon (I).

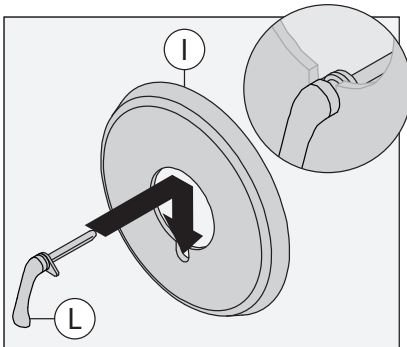

- 3) Attach shower escutcheon (I) to mounting plate (K).

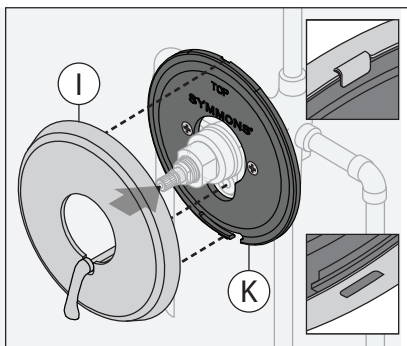

**Note:** Tabs should snap into place.

- 4) Install diverter escutcheon (H) to diverter valve. Secure with two screws (G).

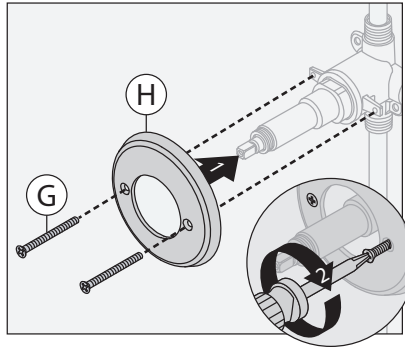

- 5) Install dome covers (F) to valves. Turn clockwise to secure.

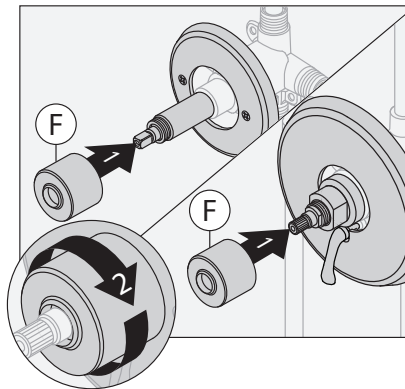

- 6) Install handles (D) to valves. Secure with set screws (E).

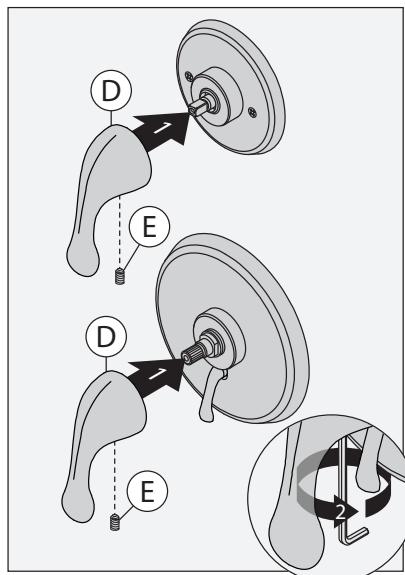

**Note:** Handles should be facing the 6 o'clock position.

- 7) Attach shower arm (B) and flange (C) to vertical shower pipe. Turn clockwise to tighten.

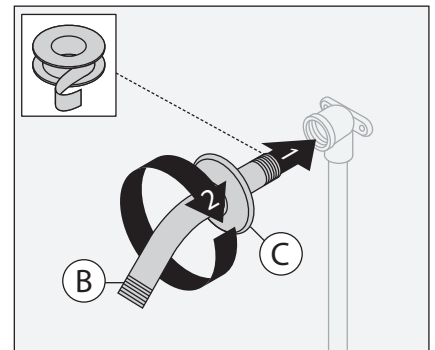

- 8) Install showerhead (A) to shower arm (B). Turn clockwise to tighten.

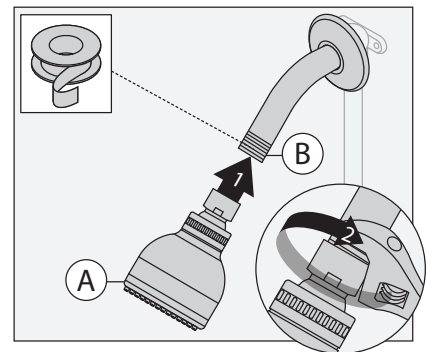

- 9) Install wall ell (Q) to pipe fitting. Tighten set screw (R) to secure.

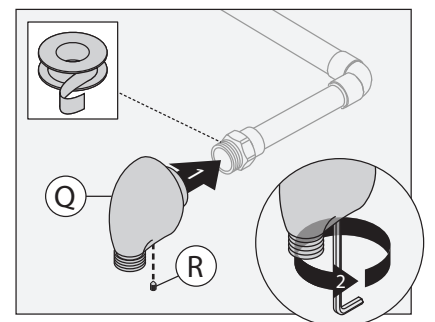

## Installation

- 10) Place mounting plate (N) in position, mark and drill 3/16" holes for tile anchors (N1), 5/16" holes for drywall anchors (N2). Install anchors.

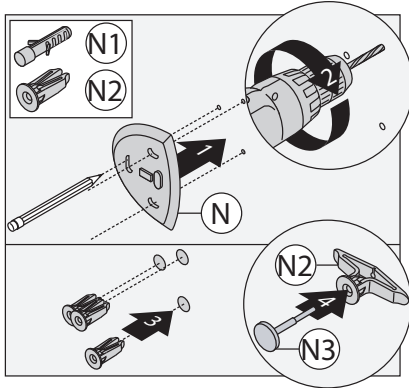

**Note:** For drywall 1/2" thick or less, insert anchor tool (N3) into drywall anchor (N2) to secure behind wall prior to installing wall cradle.

- 11) Remove cover of hand shower cradle (O). Install cradle and mounting plate (N). Secure with three screws (P). Replace cover on hand shower cradle.

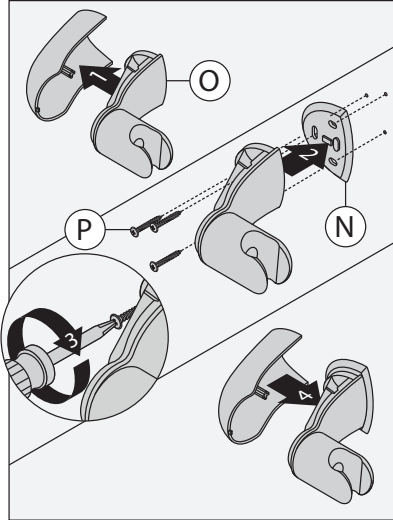

- 12) Attach hand shower (M) to hose (T). Attach hose (T) to vacuum breaker (S). Connect vacuum breaker (S) to wall ell (Q). Turn clockwise to tighten.

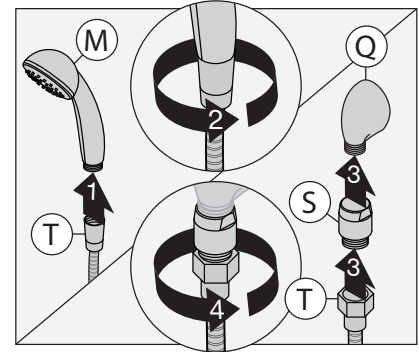

- 13) Install tub spout (U) to pipe fitting. Turn clockwise to secure.

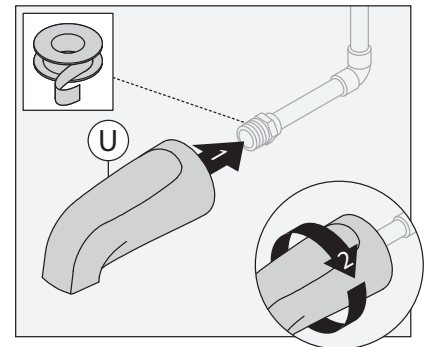

## Operation (Temperature Control)

- 1) Turn shower handle counterclockwise approximately 1/4 turn to put valve in cold position.

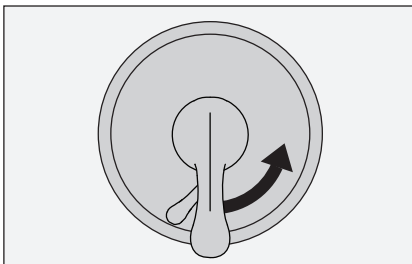

- 2) Turn shower handle counterclockwise approximately 1/2 turn to put valve in warm position.

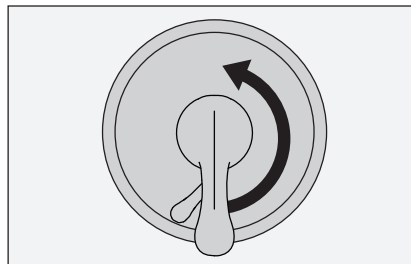

- 3) Turn shower handle counterclockwise approximately 3/4 turn to put valve in hot position.

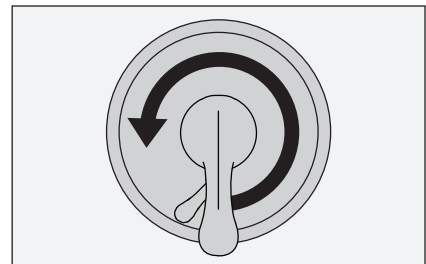

## Operation (Diverter Control)

1) Cartridge is factory set to divert to function 1.

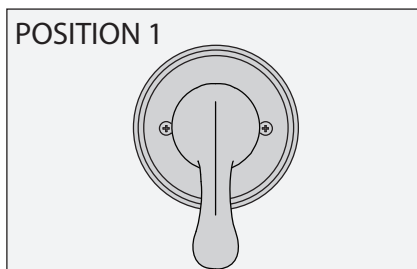

2) Turn handle to position 2 to divert to function 2.

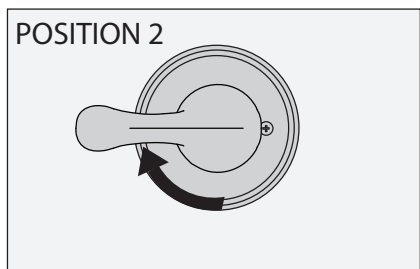

3) Turn handle to position 3 to share functions 1 and 2.

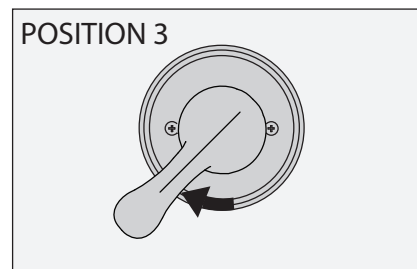

**Note:** In this position there is no detent.

## Operation (Secondary Integrated Diverter Control)

1) Turn secondary integrated diverter handle left for tub spout operation.

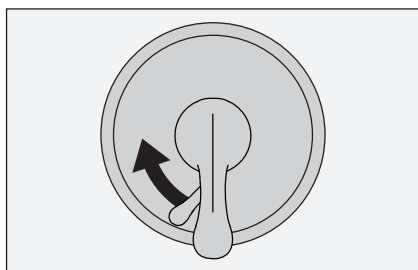

2) Turn secondary integrated diverter handle right for diverter valve operation.

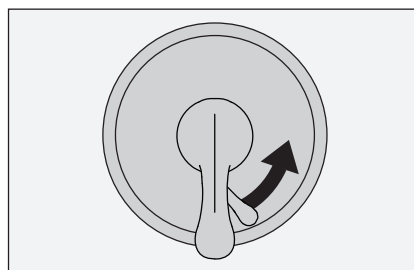







## Troubleshooting Chart

Problem	Cause	Solution
Finish is spotting.	Elements in water supply may cause water staining on finish.	Clean finished trim area with a soft cloth using mild soap and water or a non-abrasive cleaner and then quickly rinse with water.

S-6606

Sistema de bañera/ducha/ducha de mano  
**Manual de funcionamiento y mantenimiento**



Números de modelo	Especificación
<input type="checkbox"/> <b>S-6606</b> <i>Sistema de bañera/ducha/ducha de mano Unity</i>	<p>Sistema para ducha/ducha de mano con válvula compensadora de presión Temptrol®. Incluye un tornillo con tope ajustable para limitar el giro de la manija, control secundario integrado de desvío, soporte de pared, desviador separado de dos funciones, surtidor de bañera sin desviador, igualador de presión integrado, manguera metálica flexible de 60", ducha de mano de 1 función, cabezal de ducha de 1 función con boquillas de goma fáciles de limpiar y reductor de caudal estándar de 2.5 gpm (9.5 L/min). Los componentes están hechos de materiales metálicos y no metálicos recubiertos con un acabado en cromo pulido estándar.</p> <div style="text-align: right;">   </div>
<p><b>Modificaciones</b></p>	
<input type="checkbox"/> <b>-1.5</b>  Reductor de caudal de 1.5 gpm (5.7 L/min)	
<input type="checkbox"/> <b>-2.0</b>  Reductor de caudal de 2.0 gpm (7.6 L/min)	
<input type="checkbox"/> <b>-143</b> Cabezal de ducha de tres funciones Euro-Flo en lugar de Clear-Flo	
<input type="checkbox"/> <b>-145</b> Cabezal de ducha de cinco funciones Euro-Flo en lugar de Clear-Flo	
<input type="checkbox"/> <b>-231</b> Cabezal de ducha Super en lugar de Clear-Flo	
<input type="checkbox"/> <b>-SS</b> Surtidor de montaje deslizante en cualquiera de las unidades para bañera y ducha	
<input type="checkbox"/> <b>-X</b> Llaves de paso integradas	
<input type="checkbox"/> <b>-CHKS</b> Válvulas de retención integradas	
<input type="checkbox"/> <b>-IPS</b> Salida de unión hembra de 1/2" I.P.S.	
<input type="checkbox"/> <b>-REV</b> Conexión inversa para instalaciones encontradas	
<input type="checkbox"/> <b>-LP</b> Manija en bucle	
<input type="checkbox"/> <b>-QD</b> Desconexión rápida en unidades de ducha de mano	
<input type="checkbox"/> <b>-R</b> Manguera de vinilo blanco en lugar de la manguera de metal	
<input type="checkbox"/> <b>-OP</b> Placa ovalada de 13"	
<input type="checkbox"/> <b>-L/HD</b> Sin el cabezal de ducha	
<input type="checkbox"/> <b>-72</b> Manguera de 6 pies en vez de la estándar de 5 pies	
<input type="checkbox"/> <b>-TRM</b> Borde solamente, válvula no incluida	
<input type="checkbox"/> <b>-STN</b> Acabado de níquel satinado	
<p><b>Cumplimiento</b></p>	<p>-ASME A112.18.1/CSA B125.1</p>
<p><b>Garantía</b></p>	<p>-WaterSense 1.5 gpm (5.7 L/min) 2.0 gpm (7.6 L/min)</p> <div style="text-align: right;">   </div>
<p><b>Garantía</b></p>	<p><b>Vida útil limitada</b> - al comprador final original en instalaciones del consumidor/residenciales. <b>5 años</b> - para instalaciones industriales y comerciales. Consulte <a href="http://www.symmons.com/warranty">www.symmons.com/warranty</a> para obtener información completa sobre la garantía.</p>
<p><b>Nota:</b> Anexar el -sufijo apropiado al número de modelo.</p>	



## Dimensiones

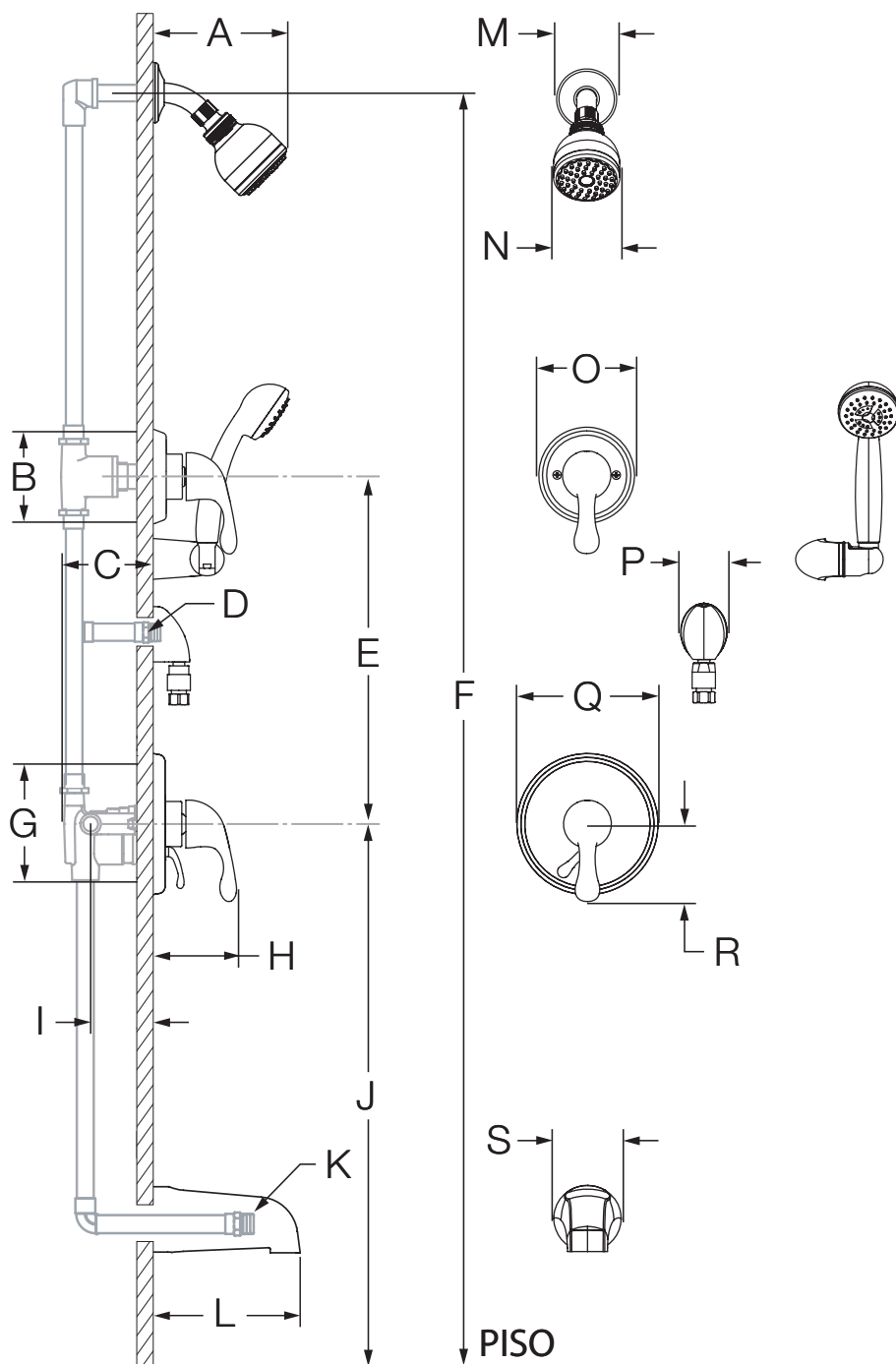

Medidas	
A	6 3/8", 162 mm
B	Tamaño de los orificios de la válvula de desvío Mín. Ø 3", 76 mm Máx. Ø 3 1/4", 83 mm
C	3 1/2", 89 mm
D	La rosca macho NPT de 1/2" debe estar empotrada 1/4" de la pared terminada
E	Ref. 10", 254 mm
F	Ref. 77", 1956 mm
G	Tamaño de los orificios de la válvula para ducha Mín. Ø 3", 76 mm Máx. Ø 4", 102 mm
H	3 3/4", 95 mm
I	Empotrado 2 3/8" ± 1/2", 60 mm ± 13 mm
J	Ref. 32", 813 mm
K	La rosca macho NPT de 1/2" debe sobresalir 4" de la pared terminada
L	5 1/2", 140 mm
M	Ø 2 1/2", 64 mm
N	Ø 2 3/4", 70 mm
O	Ø 4 1/4", 108 mm
P	2 1/8", 54 mm
Q	Ø 6 3/8", 162 mm
R	3 1/2", 89 mm
S	Ø 2 1/2", 64 mm

### Notas:

- 1) Todas las dimensiones tomadas desde el empotrado (ver I para referencia).
- 2) Las dimensiones están sujetas a cambios sin previo aviso.



## Desglose de piezas

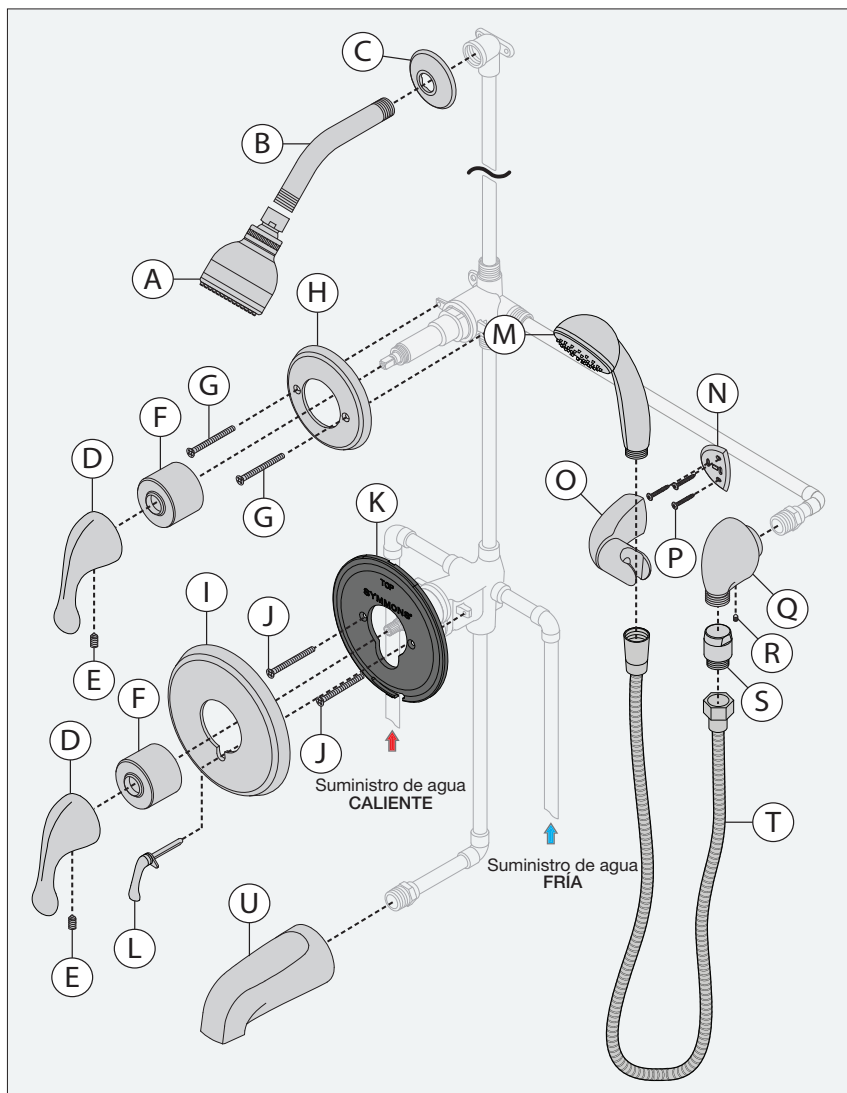

### Notas:

- 1) Aplique una gota de silicona alrededor del perímetro del borde de la ducha a nivel de la pared terminada. Deje un orificio en la parte inferior de la placa para drenar la humedad.
- 2) Coloque cinta de teflón en todas las salidas de unión roscadas.

### Repuestos

Art.	Descripción	Número de pieza
A	Cabezal de ducha	4-141*
B	Brazo de la ducha y brida	300S*
C		
D	Conjunto de manija de ducha o desviador	RTS-064*
E		
F	Cubierta del domo	T-19*
G	Kit de placa decorativa del desviador	96-66-DIV-ESC*
H		
I	Kit de placa decorativa para la ducha	S-6600TS-ESC*
J		
K		
L	Manija de desvío secundaria integrada	RTS-066*
M	Ducha de mano	EF-100*
N	Soporte de pared	EF-106*
O		
P		
Q	Codo de pared	EF-105*
R		
S	Igualador de presión integrado y manguera de 60"	SP-4*
T		
U	Surtidor para bañera	060

**\*Nota:** Anexar -STN al número de pieza para el acabado de níquel satinado.

### Herramientas requeridas

Llave inglesa	
Llave Allen (1/8")	
Taladro	
Destornillador phillips	
Cinta de teflón	
Silicona	

## Instalación

### Nota:

Para instalar el cuerpo de la válvula, vea el manual de la válvula.

- 1) Instale la placa de montaje (K) a la válvula de la ducha. Sujete con dos tornillos (J).

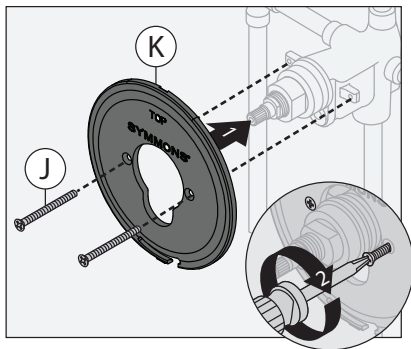

- 2) Instale la manija de desvío secundaria integrada (L) en la placa decorativa de la ducha (I).

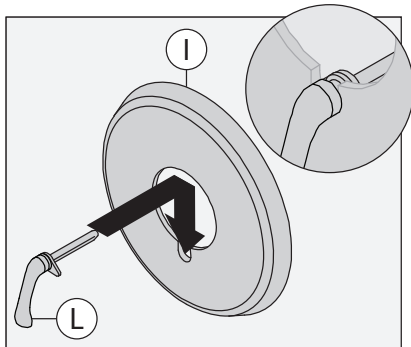

- 3) Una el montaje decorativo de la ducha (I) a la placa de montaje (K).

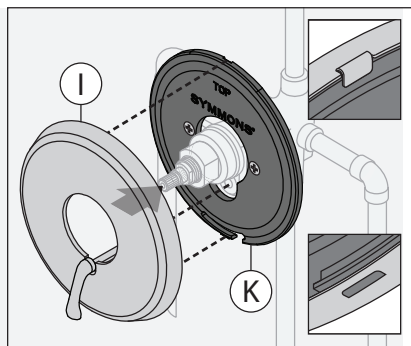

**Nota:** Las lengüetas deben encajar en sus sitios.

- 4) Instale la placa decorativa del desviador (H) en la válvula de desvío. Sujete con dos tornillos (G).

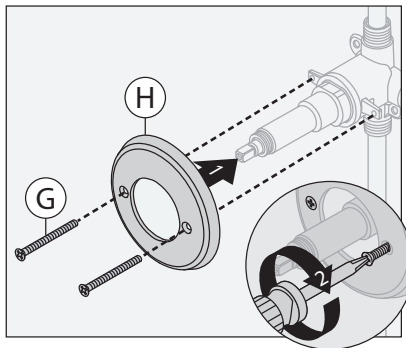

- 5) Instale las cubiertas de domo (F) en las válvulas. Gire en el sentido de las manecillas del reloj para apretar.

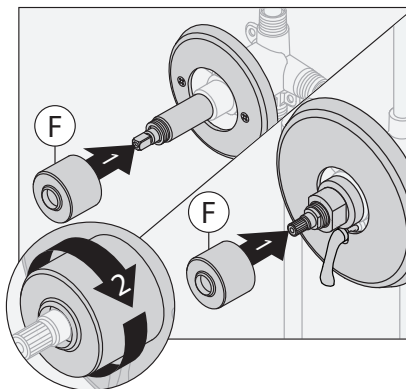

- 6) Instale las manijas (D) en las válvulas. Sujételas con los tornillos de presión (E).

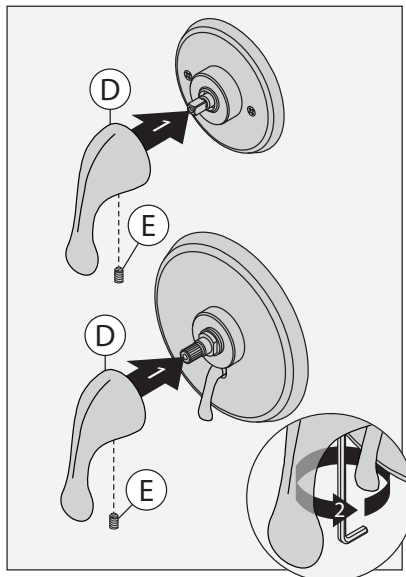

**Nota:** Las manijas deben situarse en la posición de las 6 en punto.

- 7) Una el brazo de la ducha (B) y la brida (C) al tubo vertical de la ducha. Gire en el sentido de las manecillas del reloj para apretar.

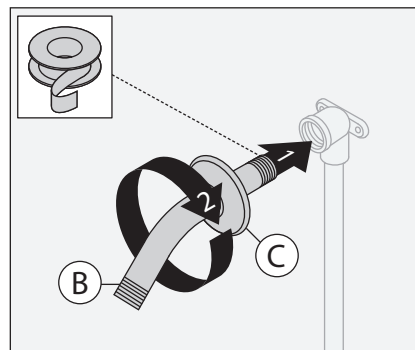

- 8) Instale el cabezal de ducha (A) al brazo de la ducha (B). Gire en el sentido de las manecillas del reloj para apretar.

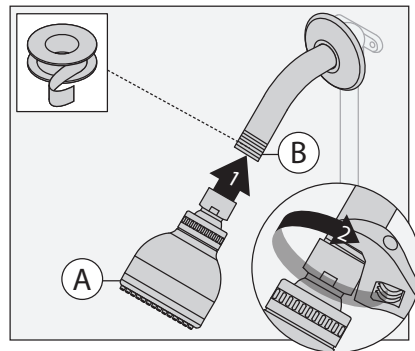

- 9) Instale el codo de pared (Q) en el conector de la tubería. Apriete el tornillo de presión (R) para sujetarlo.

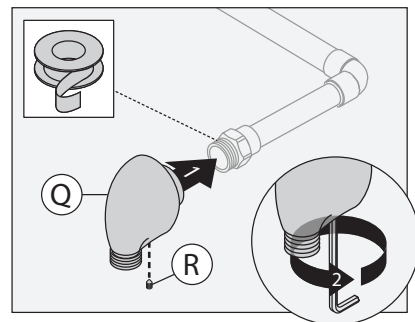

## Instalación

- 10) Coloque la placa de montaje (N) en su posición, marque y taladre agujeros de 3/16" para las anclas para mosaico (N1), agujeros de 5/16" para las anclas para yeso (N2). Instale las anclas.

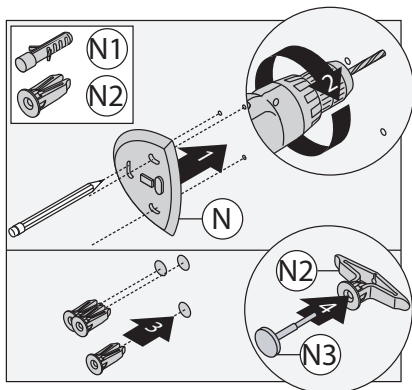

**Nota:** Para paredes de yeso de 1/2" de grosor o menos inserte la herramienta para anclas (N3) en la ancla para yeso (N2) para sujetarla detrás de la pared antes de instalar el soporte de pared.

- 11) Retire la cubierta del soporte de la ducha de mano (O). Instale el soporte y la placa de montaje (N). Sujete con tres tornillos (P). Vuelva a colocar la cubierta del soporte de la ducha de mano.

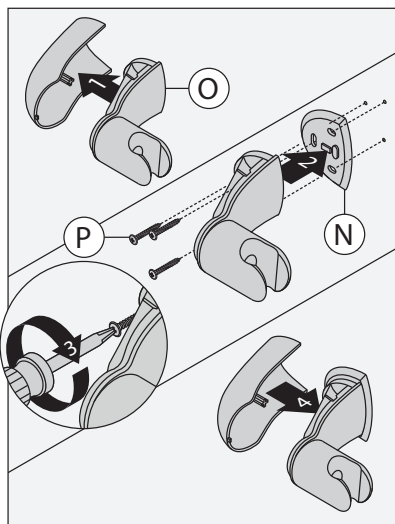

- 12) Conecte la ducha de mano (M) con la manguera (T). Conecte la manguera (T) con el igualador de presión (S). Conecte el igualador de presión (S) con el codo de pared (Q). Gire en el sentido de las manecillas del reloj para apretar.

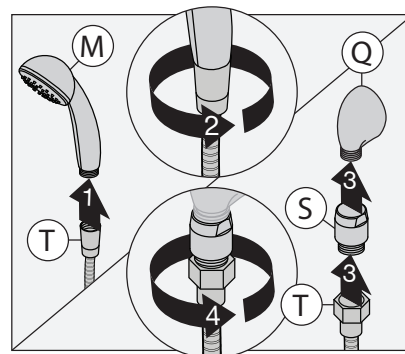

- 13) Instale el surtidor para la bañera (U) a la conexión de la tubería. Gire en el sentido de las manecillas del reloj para apretar.

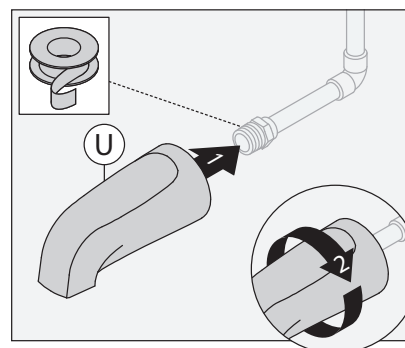

## Funcionamiento (Control de temperatura)

- 1) Gire el mango de la ducha 1/4 de vuelta en sentido contrario a las agujas del reloj para colocar la válvula en la posición de agua fría.

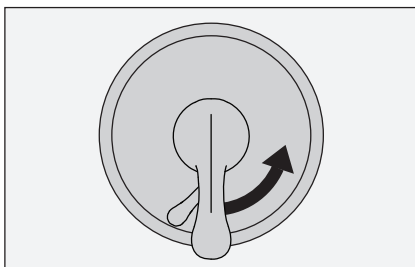

- 2) Gire el mango de la ducha 1/2 vuelta en sentido contrario a las agujas del reloj para colocar la válvula en la posición de agua tibia.

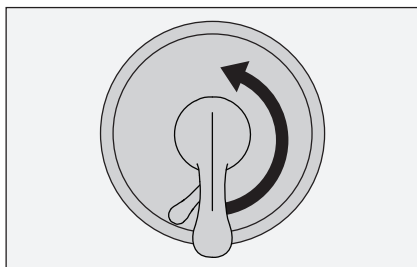

- 3) Gire el mango de la ducha 3/4 de vuelta en sentido contrario a las agujas del reloj para colocar la válvula en la posición de agua caliente.

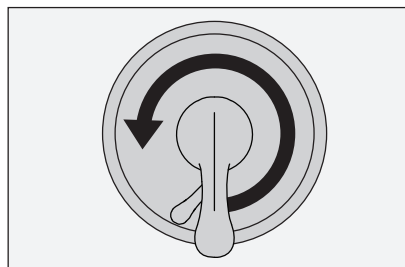

## Funcionamiento (Control de desviador)

1) El cartucho viene preconfigurado para desvío a la función 1.

POSICIÓN 1

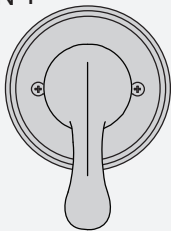

2) Gire la manija a la posición 2 para desviar a la función 2.

POSICIÓN 2

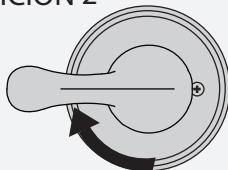

3) Gire la manija a la posición 3 para compartir las funciones 1 y 2.

POSICIÓN 3

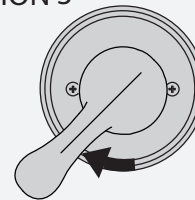

**Nota:** En esta posición no hay ninguna retén.

## Funcionamiento (Control de desvío secundario integrado)

1) Gire el mango del desviador secundario integrado hacia la izquierda para hacer funcionar el surtidor para bañera.

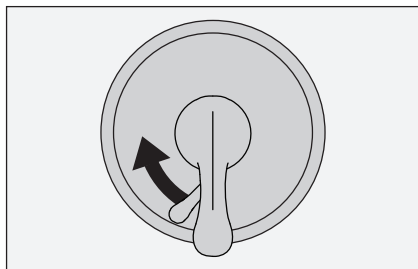

2) Gire el mango del desviador secundario integrado hacia la derecha para hacer funcionar la válvula de desvío.

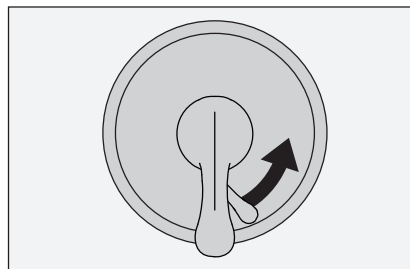

## Tabla de resolución de problemas







Problema	Causa	Solución
El acabado se está manchando.	Las partículas en el suministro de agua pueden provocar que el agua manche el acabado.	Limpie el área con acabado con un paño suave, usando jabón suave y agua o un limpiador no abrasivo, y luego enjuague rápidamente con agua.

S-6606

Système de douche/douche à main/baignoire

**Manuel d'utilisation et d'entretien**



Numéros de modèle	Spécifications
<input type="checkbox"/> <b>S-6606</b> <i>Système de douche à main/douche/baignoire Unity</i>	<p>Système de douche/douche à main alimenté par la vanne à pression autorégularisée Temptrol<sup>®</sup>. Comprend la vis d'arrêt réglable pour limiter le tournage de la poignée, un organe de dérivation secondaire intégré, un support mural, un organe de dérivation séparé à deux fonctions, un bec de baignoire non-inverseur, un brise-vide en ligne, un tuyau de métal flexible de 60 po, une douche à main à mode unique, une pomme de douche à mode unique avec des embouts en caoutchouc faciles à nettoyer et un réducteur de débit standard de 2,5 gpm (9,5 L/min). Les composants sont faits de matériaux métalliques et non métalliques au fini chrome poli standard.</p> <div style="text-align: right;">   </div>
<p><b>Modifications</b></p>	
<input type="checkbox"/> <b>-1.5</b>  Réducteur de débit de 1,5 gpm (5,7 L/min)	
<input type="checkbox"/> <b>-2.0</b>  Réducteur de débit de 2,0 gpm (7,6 L/min)	
<input type="checkbox"/> <b>-143</b> <i>Pomme de douche Euro-Flo à trois modes au lieu du Clear-Flo</i>	
<input type="checkbox"/> <b>-145</b> <i>Pomme de douche Euro-Flo à cinq modes au lieu du Clear-Flo</i>	
<input type="checkbox"/> <b>-231</b> <i>Super pomme de douche au lieu du Clear-Flo</i>	
<input type="checkbox"/> <b>-SS</b> <i>Bec de baignoire à enfiler sur toute unité de baignoire-douche</i>	
<input type="checkbox"/> <b>-X</b> <i>Robinet d'interruption du service</i>	
<input type="checkbox"/> <b>-CHKS</b> <i>Valve d'arrêt intégrée</i>	
<input type="checkbox"/> <b>-IPS</b> <i>Raccords IPS femelles de 1/2 po</i>	
<input type="checkbox"/> <b>-REV</b> <i>Corps central inversé pour installations dos à dos</i>	
<input type="checkbox"/> <b>-LP</b> <i>Poignée en boucle</i>	<p><b>Conformité</b></p> <p>-ASME A112.18.1/CSA B125.1 -WaterSense 1,5 gpm (5,7 L/min) 2,0 gpm (7,6 L/min)</p> <div style="text-align: right;">   </div>
<input type="checkbox"/> <b>-QD</b> <i>Débranchement rapide des accessoires de la douche à main</i>	
<input type="checkbox"/> <b>-R</b> <i>Tuyau de vinyle blanc au lieu du tuyau de métal</i>	
<input type="checkbox"/> <b>-OP</b> <i>Plaque ovale de 13 po</i>	
<input type="checkbox"/> <b>-L/HD</b> <i>Sans pomme de douche</i>	
<input type="checkbox"/> <b>-72</b> <i>Boyau de 6 pieds au lieu du boyau standard de 5 pieds</i>	
<input type="checkbox"/> <b>-TRM</b> <i>Garniture seulement, vanne non incluse</i>	
<input type="checkbox"/> <b>-STN</b> <i>Fini nickel satiné</i>	
	<p><b>Garantie</b></p> <p><b>À vie limitée</b> – à l'acheteur original pour les installations résidentielles/à l'usage du consommateur. <b>5 ans</b> – pour des installations commerciales et industrielles. Se reporter au site <a href="http://www.symmons.com/warranty">www.symmons.com/warranty</a> (en anglais) pour l'information concernant la garantie.</p>
<p><b>Remarque :</b> Juxtaposer le -suffixe approprié au numéro de modèle.</p>	

## Dimensions

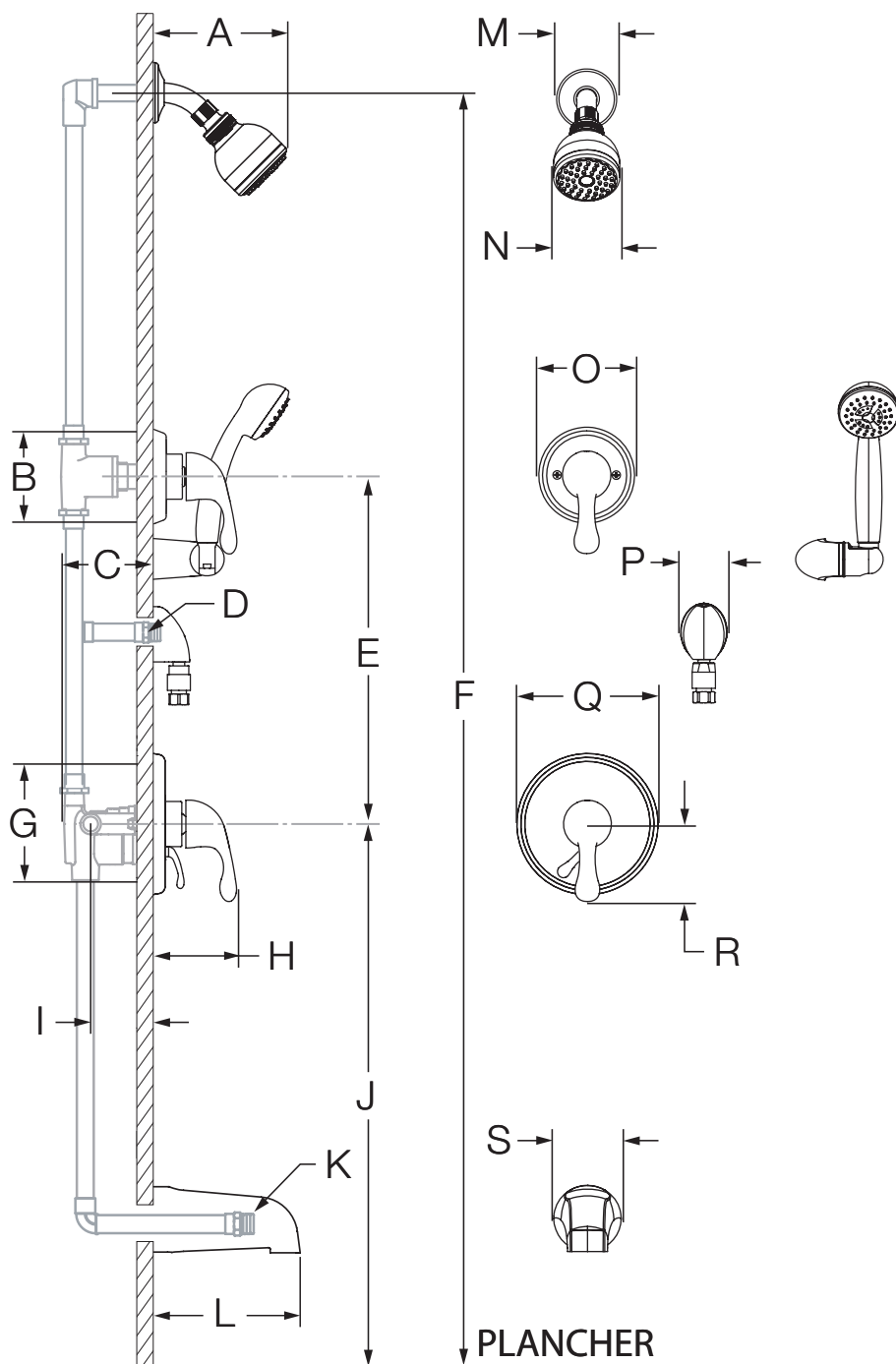

Mesures	
A	6 3/8 po, 162 mm
B	Taille de trou de la vanne de dérivation Min. Ø 3 po, 76 mm Max. Ø 3 1/4 po, 83 mm
C	3 1/2 po, 89 mm
D	Le raccord NPT 1/2 po mâle Doit être encastré à 1/4 po de la surface du mur fini
E	Réf. 10 po, 254 mm
F	Réf. 77 po, 1956 mm
G	Taille du trou pour la vanne de douche Min. Ø 3 po, 76 mm Max. Ø 4 po, 102 mm
H	3 3/4 po, 95 mm
I	Robinetterie brute 2 3/8 po ± 1/2 po, 60 mm ± 13 mm
J	Réf. 32 po, 813 mm
K	Raccord NPT 1/2 po mâle Doit faire saillie de 4 po du mur fini
L	5 1/2 po, 140 mm
M	Ø 2 1/2 po, 64 mm
N	Ø 2 3/4 po, 70 mm
O	Ø 4 1/4 po, 108 mm
P	2 1/8 po, 54 mm
Q	Ø 6 3/8 po, 162 mm
R	3 1/2 po, 89 mm
S	Ø 2 1/2 po, 64 mm

### Remarques :

- 1) Toutes les dimensions sont mesurées à partir de la robinetterie brute nominale (voir I en référence).
- 2) Les dimensions sont sujettes à modification sans préavis.

## Liste des pièces

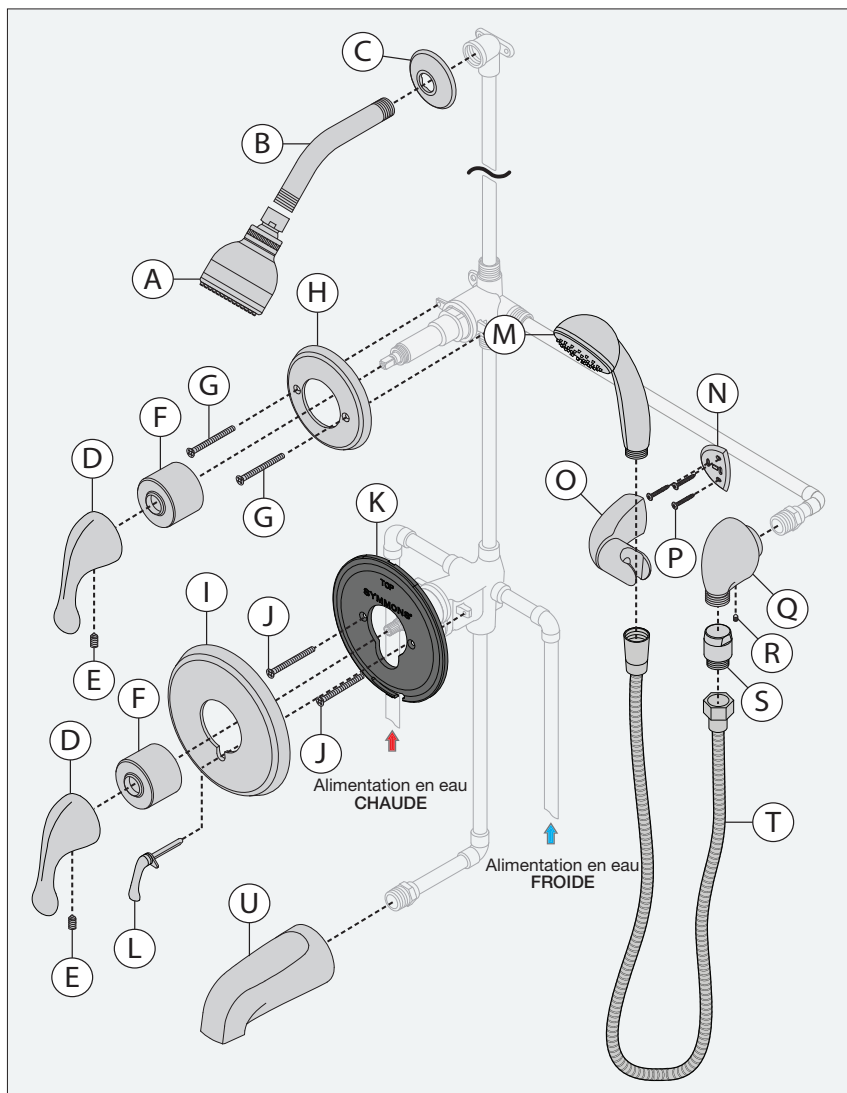





### Remarques :

- 1) Appliquez un joint de silicone autour du périmètre de la garniture de douche montée en alignement avec le mur fini. Laissez une ouverture au fond de la rosace pour évacuation.
- 2) Appliquez du ruban de plombier à toutes les connections filetées.

Pièces de remplacement		
Art.	Description	Numéro de pièce
A	Pomme de douche	4-141*
B	Bras et bride de douche	300S*
C		
D	Ensemble de poignée de dérivation ou de douche	RTS-064*
E		
F	Couvercle en dôme	T-19*
G	Ensemble de rosace pour l'organe de dérivation	96-66-DIV-ESC*
H		
I	Ensemble de rosace pour douche	S-6600TS-ESC*
J		
K		
L	Poignée de dérivation secondaire intégrée	RTS-066*
M	Douche à main	EF-100*
N		
O	Support mural	EF-106*
P		
Q		
R	Coude mural	EF-105*
S	Brise-vide en ligne et tuyau de 60 po	SP-4*
T		
U	Bec de baignoire	060

\*Remarque : Juxtaposer le -STN au numéro de pièce pour le fini nickel satiné.

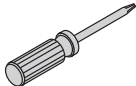
### Outils requis

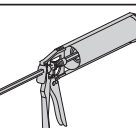
Clef ajustable	
Clef Allen (1/8 po)	
Perceuse	
Tournevis cruciforme	
Ruban de plombier	
Silicone	



## Installation

### Remarque :

Pour l'installation du corps de vanne, veuillez consulter le manuel du corps de vanne.

- 1) Installez la plaque de montage (K) à la vanne de douche. Fixez avec deux vis (J).

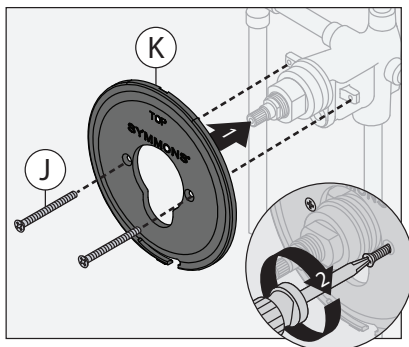

- 2) Attachez la deuxième poignée de dérivation intégrée (L) à la rosace de la douche (I).

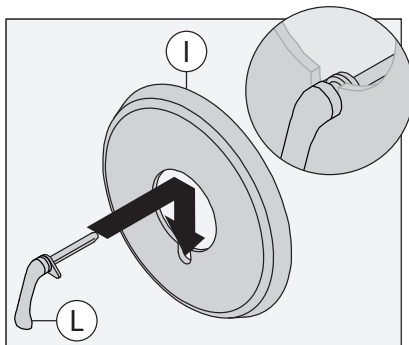

- 3) Attachez la rosace de douche (I) à la plaque de montage (K).

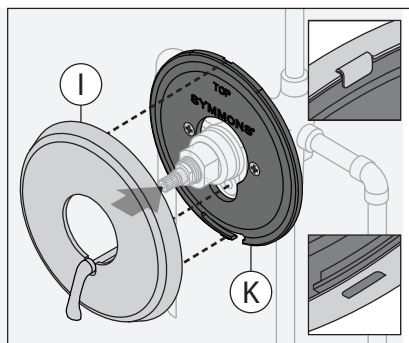

**Remarque :** Les languettes devraient s'enclencher dans la bonne position.

- 4) Installez la rosace de l'organe de dérivation (H) à la vanne de dérivation. Fixez avec deux vis (G).

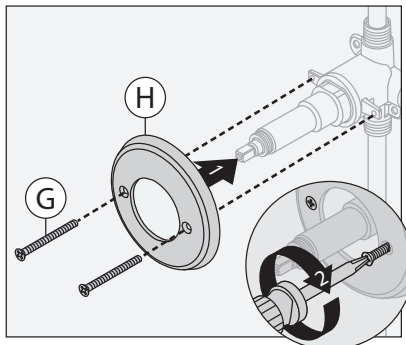

- 5) Installez les couvercles en dôme (F) sur les vannes. Tournez dans le sens des aiguilles d'une montre pour fixer en place.

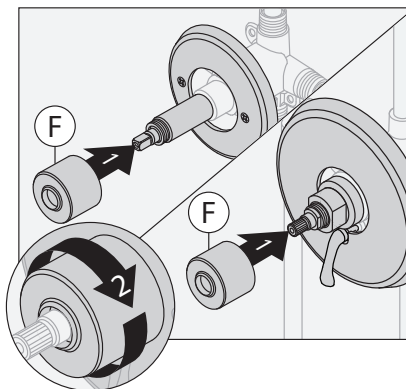

- 6) Installez les poignées (D) aux vannes. Fixez avec les vis de pression (E).

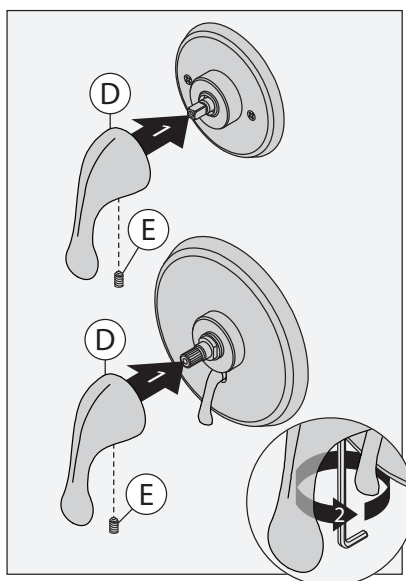

**Remarque :** Les poignées doivent être orientées vers la position 6h sur une horloge.

- 7) Attachez le bras de douche (B) et la bride (C) au tuyau de douche vertical. Tournez dans le sens des aiguilles d'une montre pour serrer.

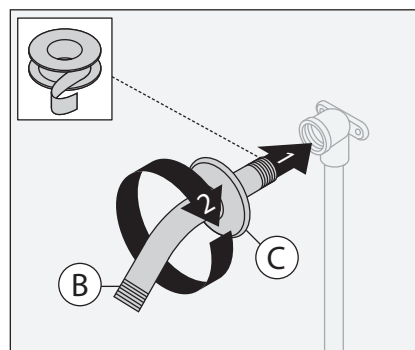

- 8) Installez la pomme de douche (A) au bras de douche (B). Tournez dans le sens des aiguilles d'une montre pour serrer.

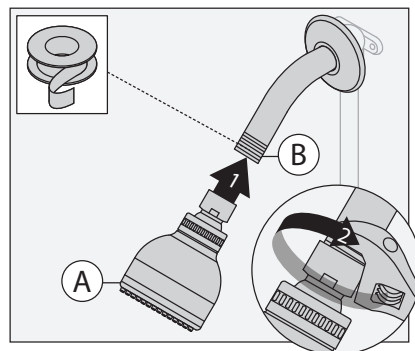

- 9) Installez le coude mural (Q) au raccord de tuyauterie. Serrez les vis de pression (R) pour fixer en place.

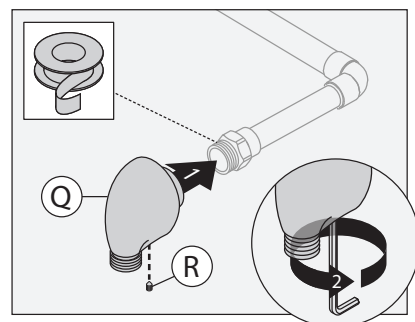

## Installation

- 10) Placez la plaque de montage (N) en position, marquez et percez des trous de 3/16 po pour l'ancrage pour céramique (N1) et des trous de 5/16 po pour l'ancrage pour cloison sèche (N2). Installez les dispositifs d'ancrage.

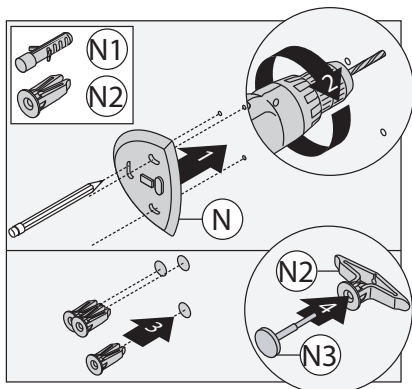

**Remarque :** Pour une cloison sèche de 1/2 po d'épaisseur ou moins, insérer l'outil d'ancrage (N3) dans le dispositif d'ancrage (N2) de la cloison pour le fixer derrière le mur avant d'installer le support mural.

- 11) Enlevez le couvercle du support de la douche à main (O). Installez le support mural et la plaque de montage (N). Fixez avec trois vis (P). Remettez le couvercle sur le support mural de la douche à main.

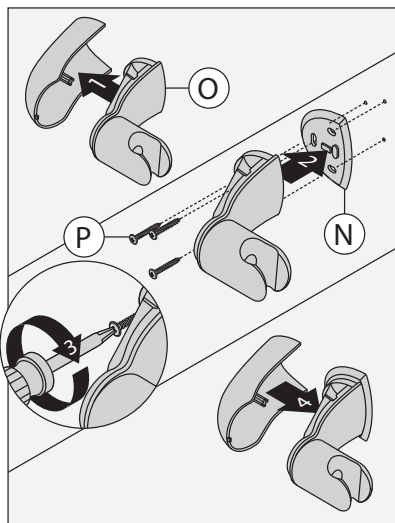

- 12) Attachez la douche à main (M) au boyau (T). Attachez le boyau (T) au brise-vide (S). Connectez le brise-vide (S) au coude mural (Q). Tournez dans le sens des aiguilles d'une montre pour serrer.

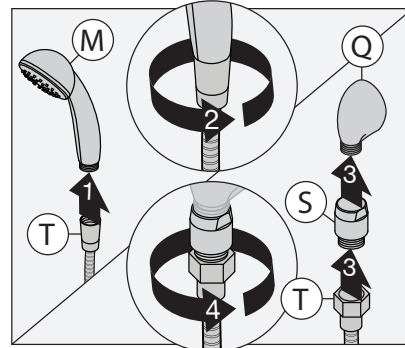

- 13) Installez le bec de baignoire (U) au raccord de tuyauterie. Tournez dans le sens des aiguilles d'une montre pour fixer en place.

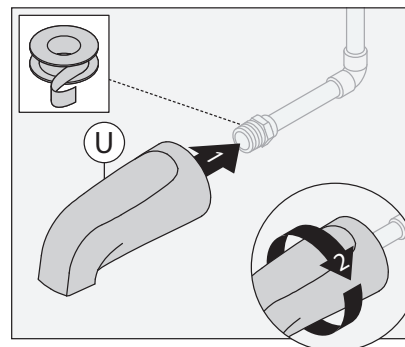

## Fonctionnement (Contrôle de la température)

- 1) Tournez la poignée de douche dans le sens contraire des aiguilles d'une montre approximativement 1/4 de tour pour mettre la vanne dans la position d'eau froide.

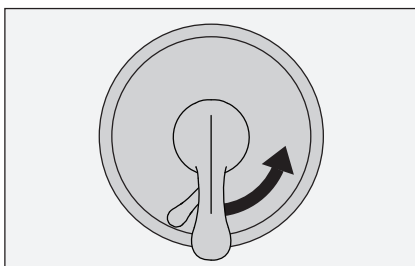

- 2) Tournez la poignée de douche dans le sens contraire des aiguilles d'une montre approximativement 1/2 de tour pour mettre la vanne dans la position d'eau tiède.

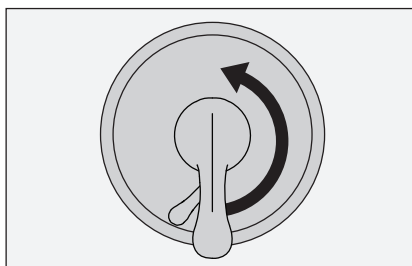

- 3) Tournez la poignée de douche dans le sens contraire des aiguilles d'une montre approximativement 3/4 de tour pour mettre la vanne dans la position d'eau chaude.

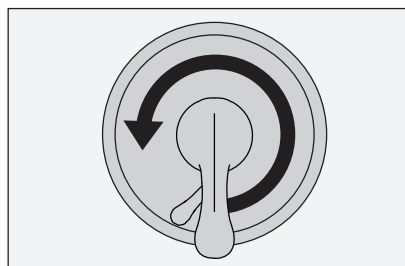

## Fonctionnement (Contrôle de la dérivation)

1) La cartouche est réglée en usine pour dévier à la fonction 1.

POSITION 1

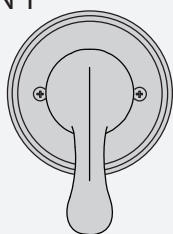

2) Tournez la poignée à la position 2 pour dévier vers la fonction 2.

POSITION 2

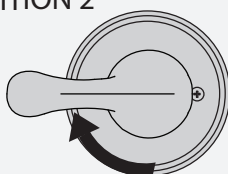

3) Tournez la poignée à la position 3 pour partager les fonctions 1 et 2.

POSITION 3

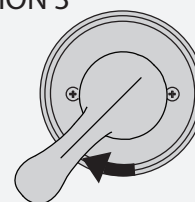

**Remarque:** Dans cette position il n'y a pas de cran.

## Fonctionnement (Contrôle de dérivation secondaire intégré)

1) Tournez la deuxième poignée de dérivation intégrée à gauche pour le fonctionnement du bec de baignoire.

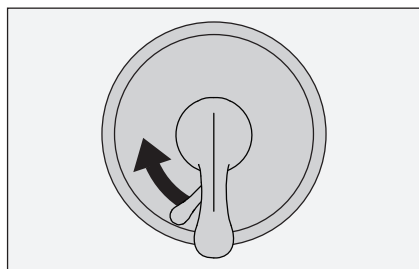

2) Tournez la deuxième poignée de dérivation intégrée à droite pour le fonctionnement de la vanne de dérivation.

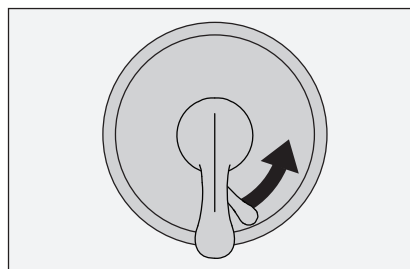

## Tableau de résolution des problèmes

Symptôme	Cause	Solution
Le fini est tâché.	Les éléments dans l'alimentation en eau peuvent causer des tâches sur le fini.	Nettoyez la boiserie avec un chiffon doux en utilisant un savon doux et de l'eau ou un nettoyant non abrasif et rincez rapidement avec de l'eau.