

SYMMONS

Volume Control Valve

341 Series

INSTALLATION, OPERATION AND SERVICE INSTRUCTIONS

INSTALLATION:

1. Thoroughly rinse the inside of pipes before fitting the valve.
2. Position the valve with the shroud (HF-139) against the finish side of the wall. Secure the valve on the back side with a stud. Note the arrow on the housing showing the direction of the water flow. Connect the inlet and outlet pipes.
3. Position the escutcheon (HF-138) on the valve and mount the shroud (HF-139) by screwing it on clockwise and tightening it.
4. Push the handle on and screw in the handle screw. Press the handle button into place (HF-148 handles only).

SERVICE:

1. Remove handle from valve.
2. Unscrew the cartridge (HF-165) with a 17 mm wrench or adjustable wrench; gently pull it out.
3. Make sure the cartridge is clean and free from dust. Oil the O-ring with vegetable oil and wipe inside of the valve housing with a wet cloth before reassembling.
4. Reassemble the valve by reversing these instructions and check the system for leaks.

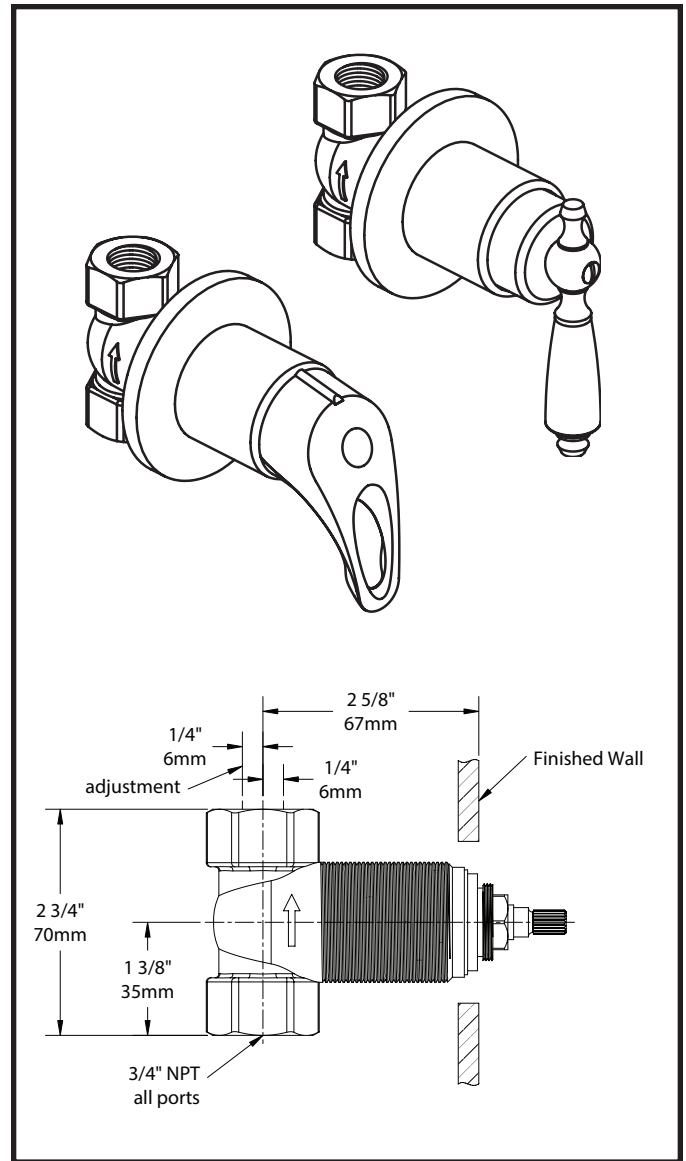

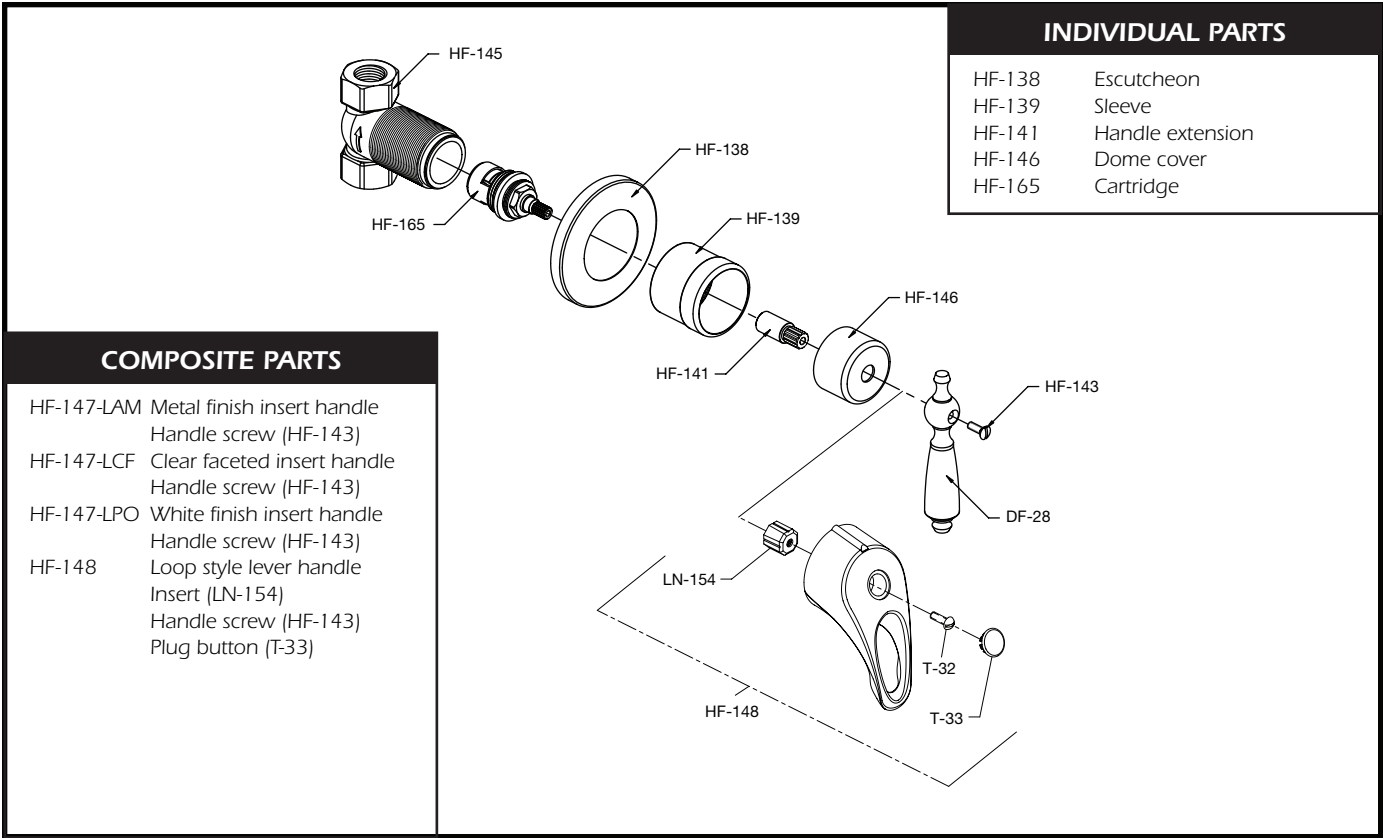

INDIVIDUAL PARTS	
HF-138	Escutcheon
HF-139	Sleeve
HF-141	Handle extension
HF-146	Dome cover
HF-165	Cartridge

COMPOSITE PARTS	
HF-147-LAM	Metal finish insert handle Handle screw (HF-143)
HF-147-LCF	Clear faceted insert handle Handle screw (HF-143)
HF-147-LPO	White finish insert handle Handle screw (HF-143)
HF-148	Loop style lever handle Insert (LN-154) Handle screw (HF-143) Plug button (T-33)

TROUBLE SHOOTING CHART

Problem	Cause	Solution (Follow service instructions)
Volume control valve leaks	Cartridge dirty Cartridge faulty	Remove and clean cartridge Replace cartridge

Lifetime Limited Warranty

Symmons warrants to the original consumer purchaser that any TEMPTROL® series* or SYMMETRIX® product will be free of defects in material and workmanship during normal domestic use for the life of your home. All other products and purchasers including industrial, commercial or business use are warranted for a period of 5 years from the date of purchase. At our option, we will either have you send the defective part or product prepaid to us for inspection, or we may elect to send you the replacement part or product without investigation. A replacement for any defective part will be supplied FREE OF CHARGE for installation by the purchaser. Defect or damage caused by the use of replacement parts other than Symmons Genuine Replacement Parts will void this warranty. This warranty excludes product damage due to installation error, product abuse, or product misuse whether performed by a contractor, service company or yourself.

Symmons further warrants that any TEMPTROL or SYMMETRIX product will be leak free and drip free during normal domestic use for the life of your home. If the product should develop a leak or drip, Symmons will provide FREE OF CHARGE the parts necessary to return it to good working condition.

Proof of purchase (original sales receipt) and a copy of the warranty registration card from the original consumer purchaser must accompany all warranty claims. This warranty is applicable only to Symmons TEMPTROL or SYMMETRIX products purchased after July 1, 1998 and shall be effective from the date of purchase as shown on the purchaser's receipt.

Damage to the chrome and/or other decorative finishes on Symmons products may be a result of improper handling or abusive treatment. Finishes should only be cleaned with a soft, damp cloth or sponge. Use of polish, abrasive cleaners, solvents, or acid cleaners will damage the finish and void this warranty.

There are no other express warranties on this product and ALL WARRANTIES OF MERCHANTABILITY AND OTHER IMPLIED WARRANTIES ARE LIMITED IN ACCORDANCE WITH APPLICABLE LAW. SYMMONS INDUSTRIES, INC., EXPRESSLY DISCLAIMS CONTINGENT LIABILITY AND CONSEQUENTIAL DAMAGE OF EVERY KIND. Since some states do not allow limitations on how long an implied warranty lasts or an exclusion or limitation of incidental or consequential damages the above limitation or exclusion may not be applicable. This warranty gives specific legal rights. Other rights may vary from state to state.

To obtain warranty service, write to Symmons Industries, Inc., 31 Brooks Drive, Braintree, MA 02184-3804 or call our Customer Service Department at 1-800-SYMMONS. If writing to us, please include proof of purchase, the model number of the product with a brief description of the problem, your name, address and phone number.

*Temptrol series includes Allura®, Olde Braintree Brass®, Temptrol, Temptrol Deluxe and Temptrol II shower and tub/shower systems.

Symmons warrants to the original consumer purchaser that any TEMPTROL® series* or SYMMETRIX® product will be free of defects in material and workmanship during normal domestic use for the life of your home. All other products and purchasers including industrial, commercial or business use are warranted for a period of 5 years from the date of purchase. At our option, we will either have you send the defective part or product prepaid to us for inspection, or we may elect to send you the replacement part or product without investigation. A replacement for any defective part will be supplied FREE OF CHARGE for installation by the purchaser. Defect or damage caused by the use of replacement parts other than Symmons Genuine Replacement Parts will void this warranty. This warranty excludes product damage due to installation error, product abuse, or product misuse whether performed by a contractor, service company or yourself.

Symmons further warrants that any TEMPTROL or SYMMETRIX product will be leak free and drip free during normal domestic use for the life of your home. If the product should develop a leak or drip, Symmons will provide FREE OF CHARGE the parts necessary to return it to good working condition.

Proof of purchase (original sales receipt) and a copy of the warranty registration card from the original consumer purchaser must accompany all warranty claims. This warranty is applicable only to Symmons TEMPTROL or SYMMETRIX products purchased after July 1, 1998 and shall be effective from the date of purchase as shown on the purchaser's receipt.

Damage to the chrome and/or other decorative finishes on Symmons products may be a result of improper handling or abusive treatment. Finishes should only be cleaned with a soft, damp cloth or sponge. Use of polish, abrasive cleaners, solvents, or acid cleaners will damage the finish and void this warranty.

There are no other express warranties on this product and ALL WARRANTIES OF MERCHANTABILITY AND OTHER IMPLIED WARRANTIES ARE LIMITED IN ACCORDANCE WITH APPLICABLE LAW. SYMMONS INDUSTRIES, INC., EXPRESSLY DISCLAIMS CONTINGENT LIABILITY AND CONSEQUENTIAL DAMAGE OF EVERY KIND. Since some states do not allow limitations on how long an implied warranty lasts or an exclusion or limitation of incidental or consequential damages the above limitation or exclusion may not be applicable. This warranty gives specific legal rights. Other rights may vary from state to state.

To obtain warranty service, write to Symmons Industries, Inc., 31 Brooks Drive, Braintree, MA 02184-3804 or call our Customer Service Department at 1-800-SYMMONS. If writing to us, please include proof of purchase, the model number of the product with a brief description of the problem, your name, address and phone number.

*Temptrol series includes Allura®, Olde Braintree Brass®, Temptrol, Temptrol Deluxe and Temptrol II shower and tub/shower systems.

Symmons Industries, Inc. ■ 31 Brooks Drive ■ Braintree, MA 02184
 Phone: (800) 796-6667 ■ Fax: (800) 961-9621
 Website: www.symmons.com ■ Email: gethelp@symmons.com

