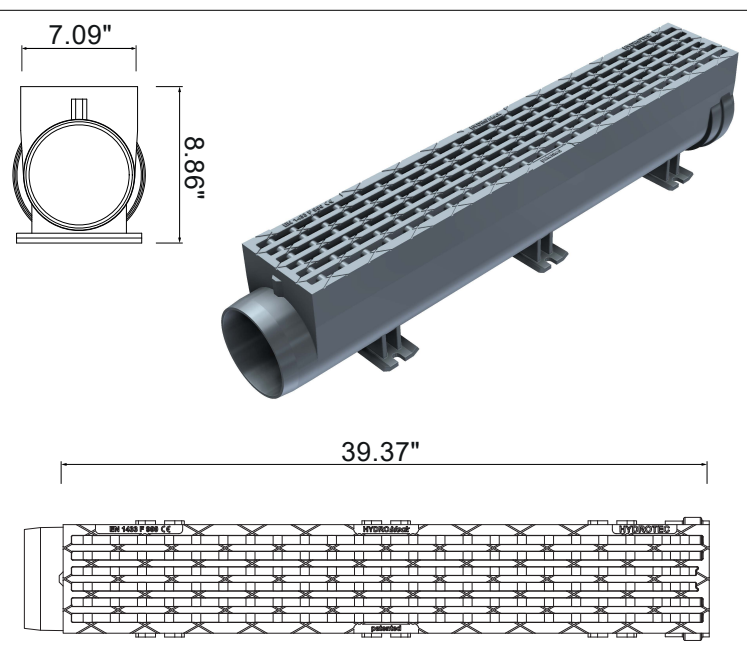
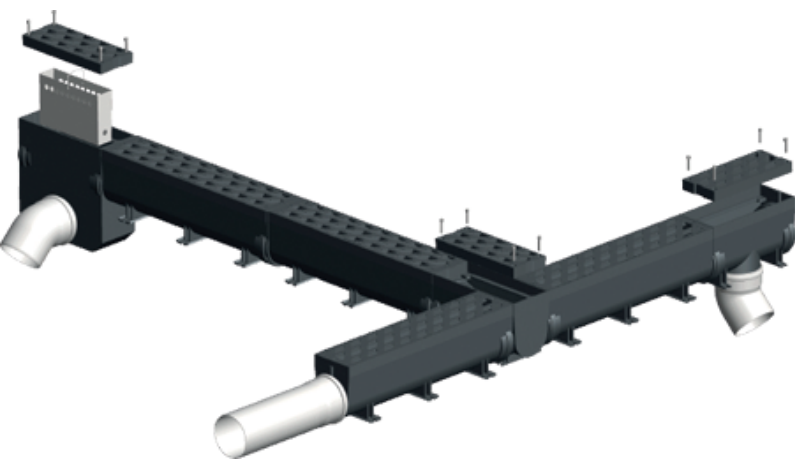

## HydroBlock 150 System Ductile Iron Channel/Grate / F900 / ADA

<p><b>Product Specifications</b></p> <p><b>Part No.:</b> 865-HB6ADA00FA</p> <p><b>Load Class:</b> F900 (198,000 lbs) according EN 1433 Certified by MPA-HB (independent laboratories)</p> <p><b>Material:</b> Ductile Iron GJS-500-7 (ASTM A536 70-50-05)</p> <p><b>Weight:</b> 116.8 lbs (53.0 kg)</p> <p><b>Surface:</b> Slot design (0.47" x 1.10") ensures high water intake. Slip-resistant design.</p> <p><b>Water Intake:</b> 59.0 sq/in (380 cm<sup>2</sup>)</p> <p><b>Locking:</b> One piece trench drain with no loose parts. Outlet sections are locked by 4 stainless steel screws.</p> <p><b>Use:</b> This channel is developed to be installed in areas with high dynamic forces. HydroBlock is qualified as "Type I" according EN 1433.</p>	
--	--

<p><b>Outlet Sections</b></p> <p><b>Bottom Outlet</b> Part No.: 865-HB6ADA005BFA</p> 	<p><b>Left/Right/End Outlet</b> Part No.: 865-HB6ADA005HSFA</p> 	<p><b>Catch Basin Part No.:</b> 865-HB6ADACBFA</p> 
--	---	--

<p><b>System Specifications</b></p> <p><b>HydroBlock 150:</b> The channel section is made of ductile iron and certified to EN 1433 Load Class F900 and is qualified as TYPE I. The gasket connection ensures a fast, watertight installation.</p> <p><b>Catch Basin (865-HB6ADACBFA):</b> The catch basin is one of 3 available outlet sections and contains a galvanized steel debris screen. It is connected to the ground pipe by a 6" pipe.</p> <p><b>Outlet Sections:</b> Outlet section length is 19.69" (1/2 m). Outlets are recommended at least every 75ft as inspection points to the channel run.</p>	
--	--