

PowerPEX[®]

▶▶ Stainless Steel Cinch Clamp Connection Guide For use with ASTM F1807/F2159 Fittings



1. Cut tube at 90-degrees. Do not crush OD of tubing with cutters. Hint: Slightly rotate cutter during blade engagement.



2. Install ASTM F2098 stainless steel cinch clamp onto OD of tube. Install fitting fully into tube.

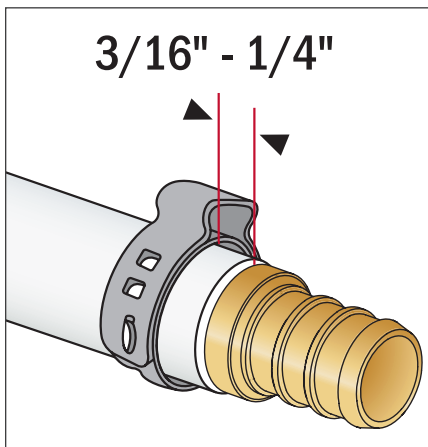

1. Position clamp between 3/16" and 1/4" from tube end to ensure coverage of both sealing barbs.

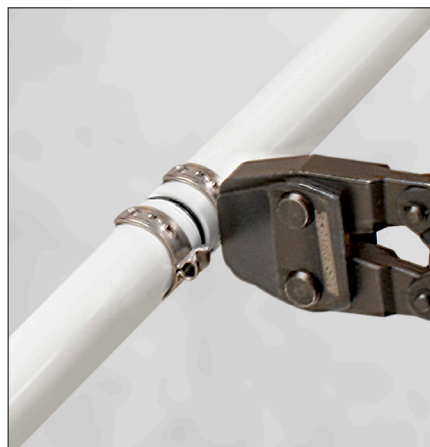

2. Close clamp ear with ratchet pincer tool. Tool will not release until clamp is fully closed. Remove any defective connections. Test all completed joints.

Note:

Full ear closure is required for proper installation. Always visually inspect clamp for correct closed-ear form.

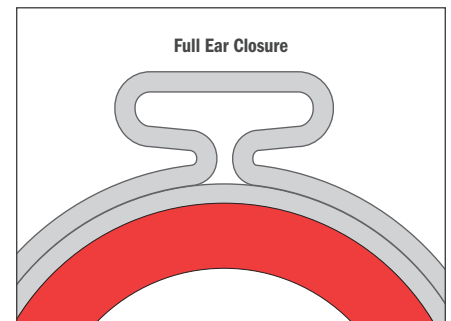

Check ratchet pincer tool calibration with a GO/NO-GO gauge daily. Refer to tool manufacturer's instructions for calibration procedures.



Installation Notes:

In high-chloride water conditions, use only polymer (ASTM F2159) fittings. Do Not install in contact with concrete. Avoid contact with soldering flux.