

SAMUEL HEATH

Product Data Sheet

V741 / V741-A Deck Mounted Diverter

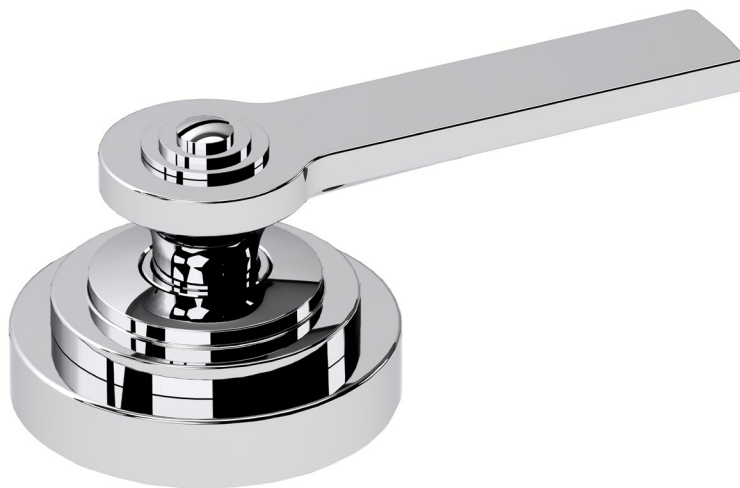

- Available Control Options -

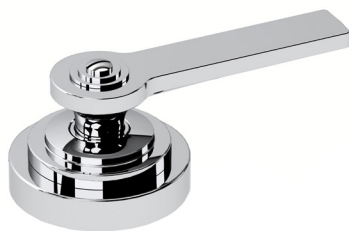

V7K41-LF



V7K41-LK



V7K41-XF



V7K41-XK

Dimension Key

V7K41LF

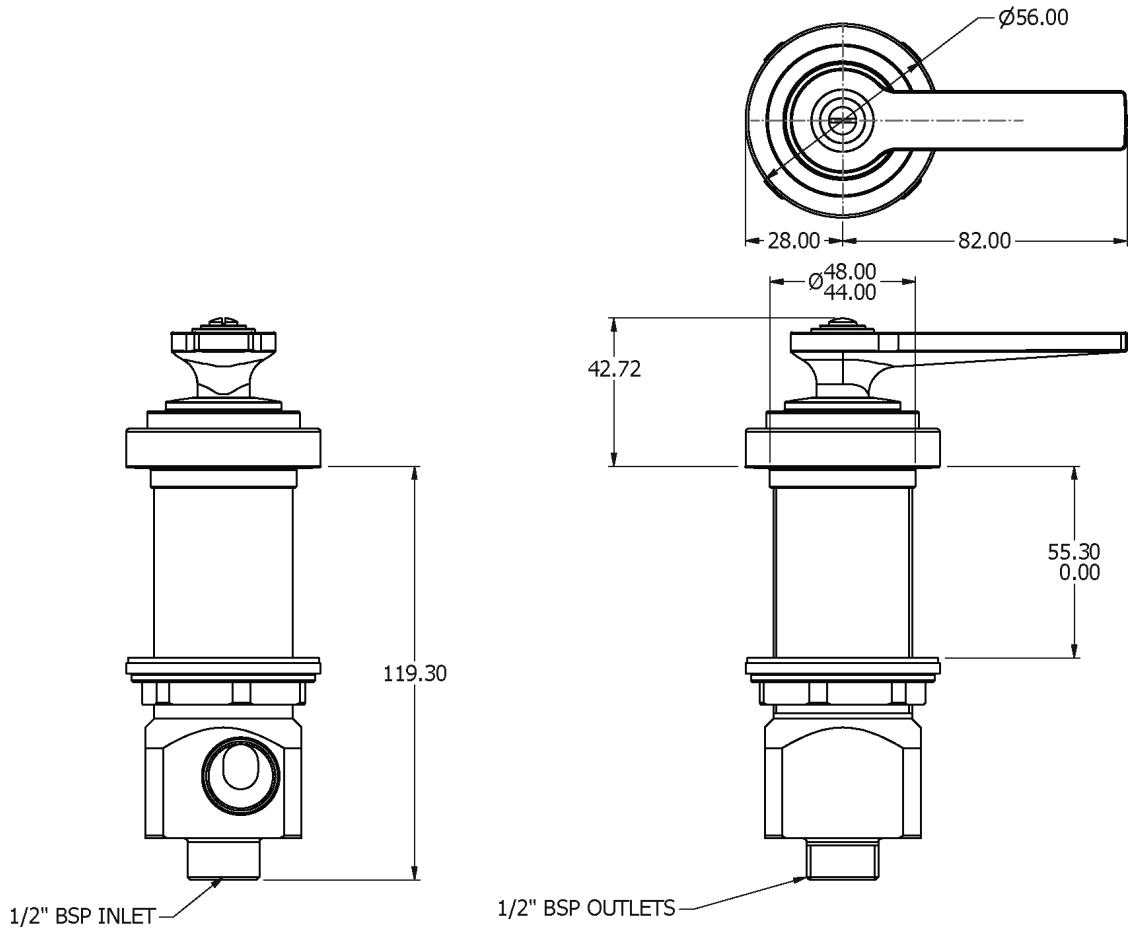

V7K41LK

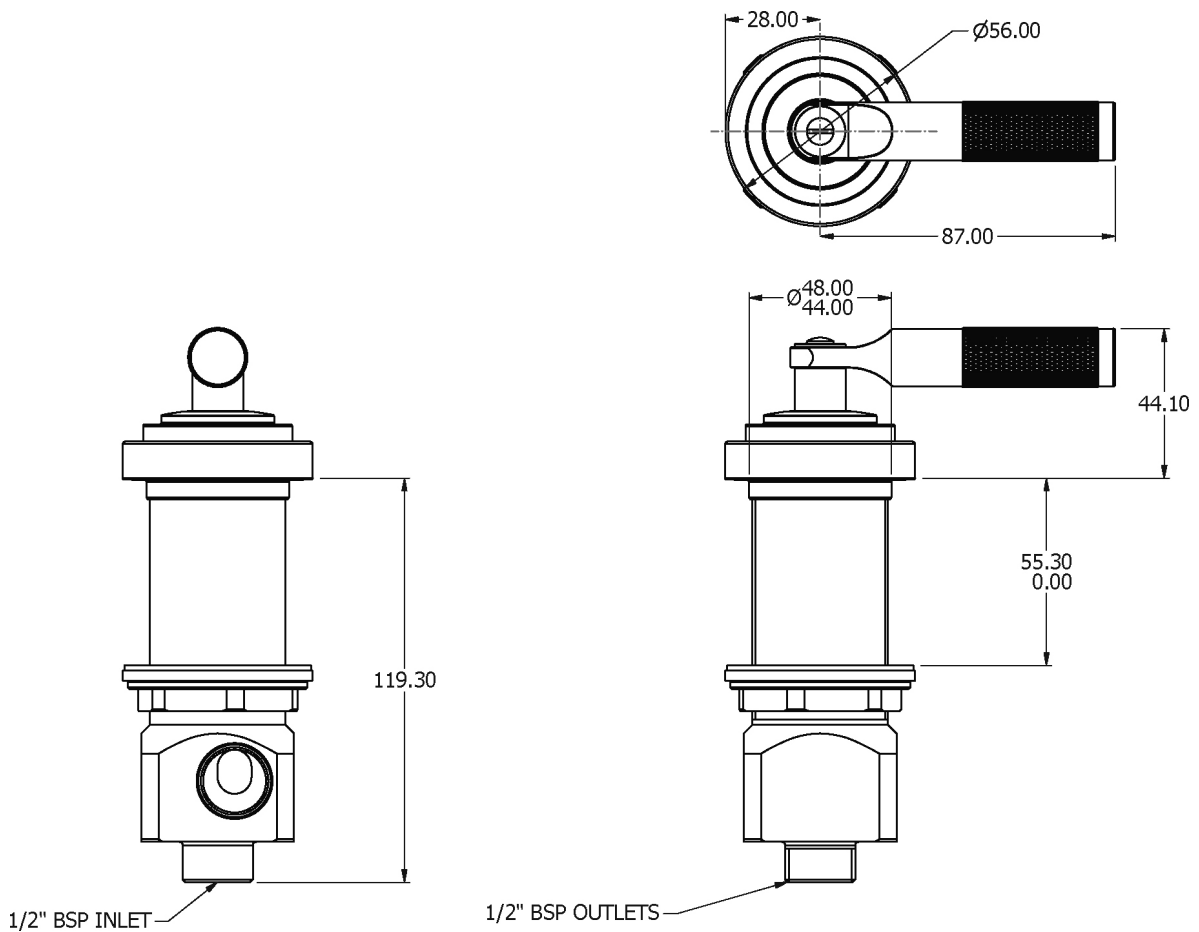

Dimension Key

V7K41XF

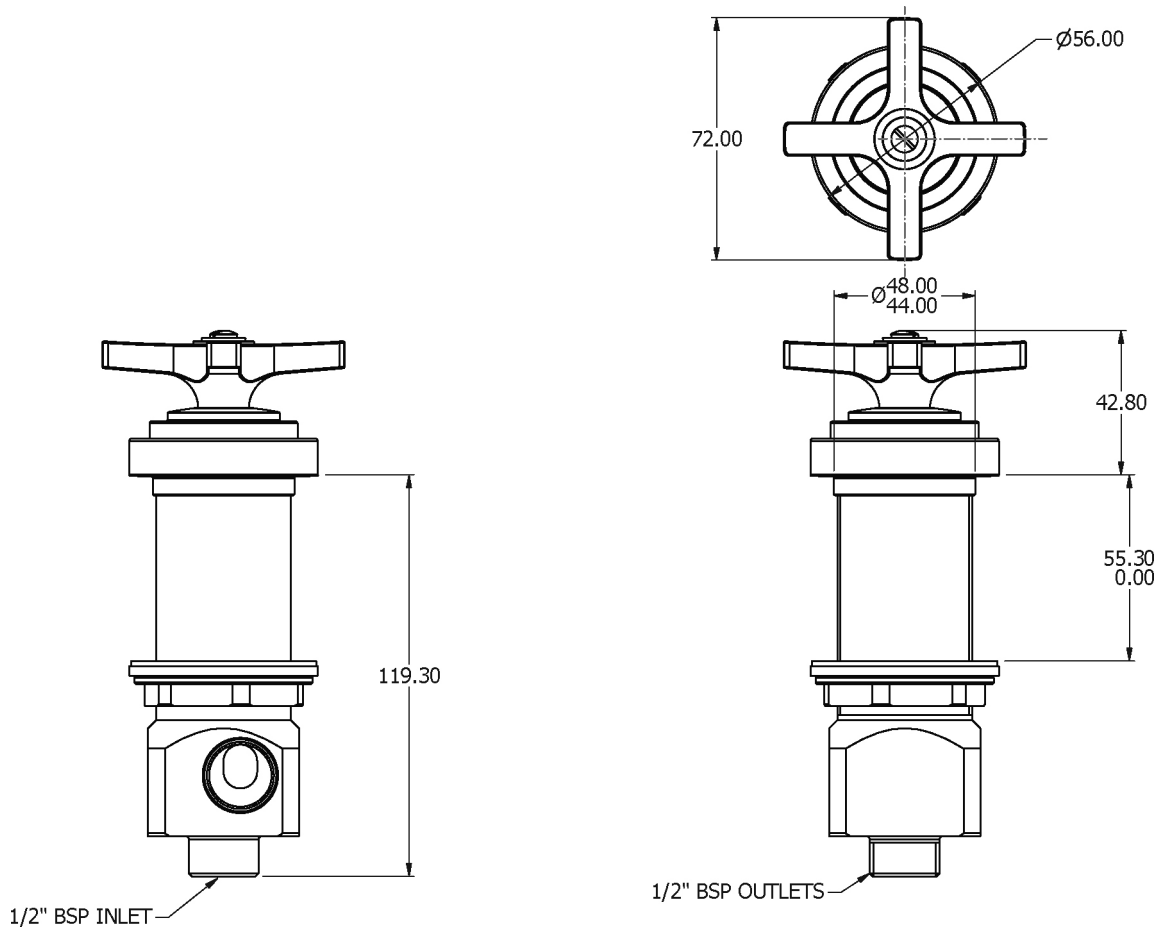

V7K41XK

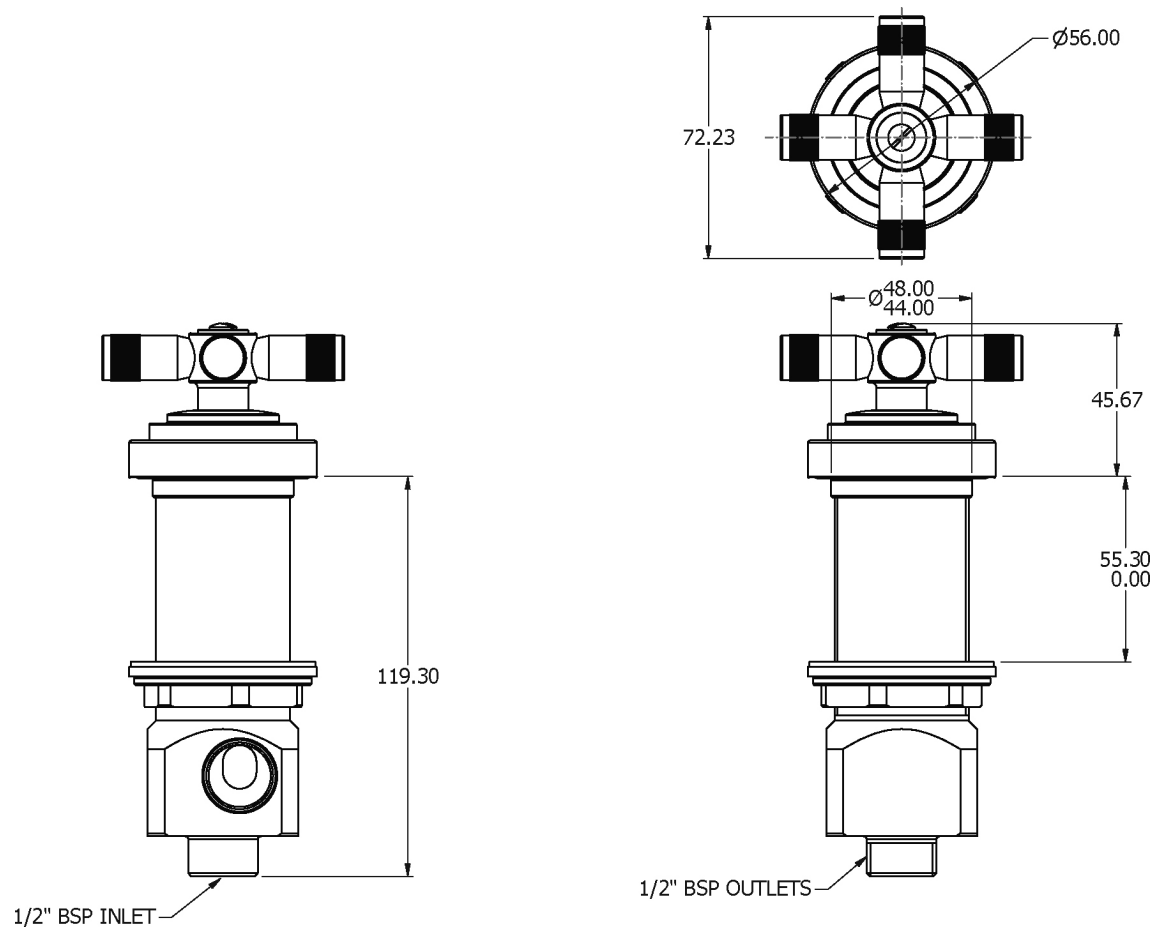

Dimension Key

V7KA41LF

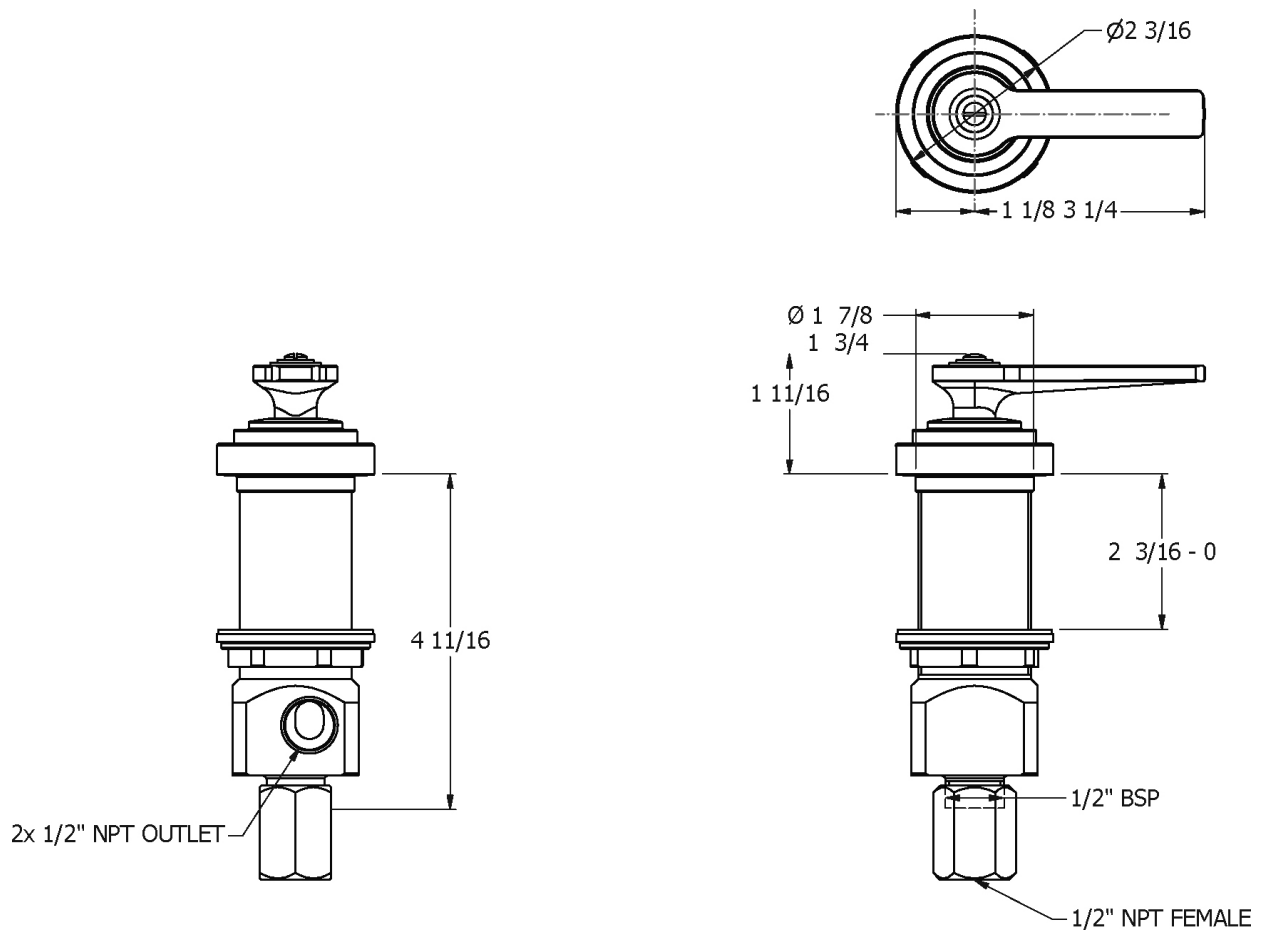

V7KA41LK

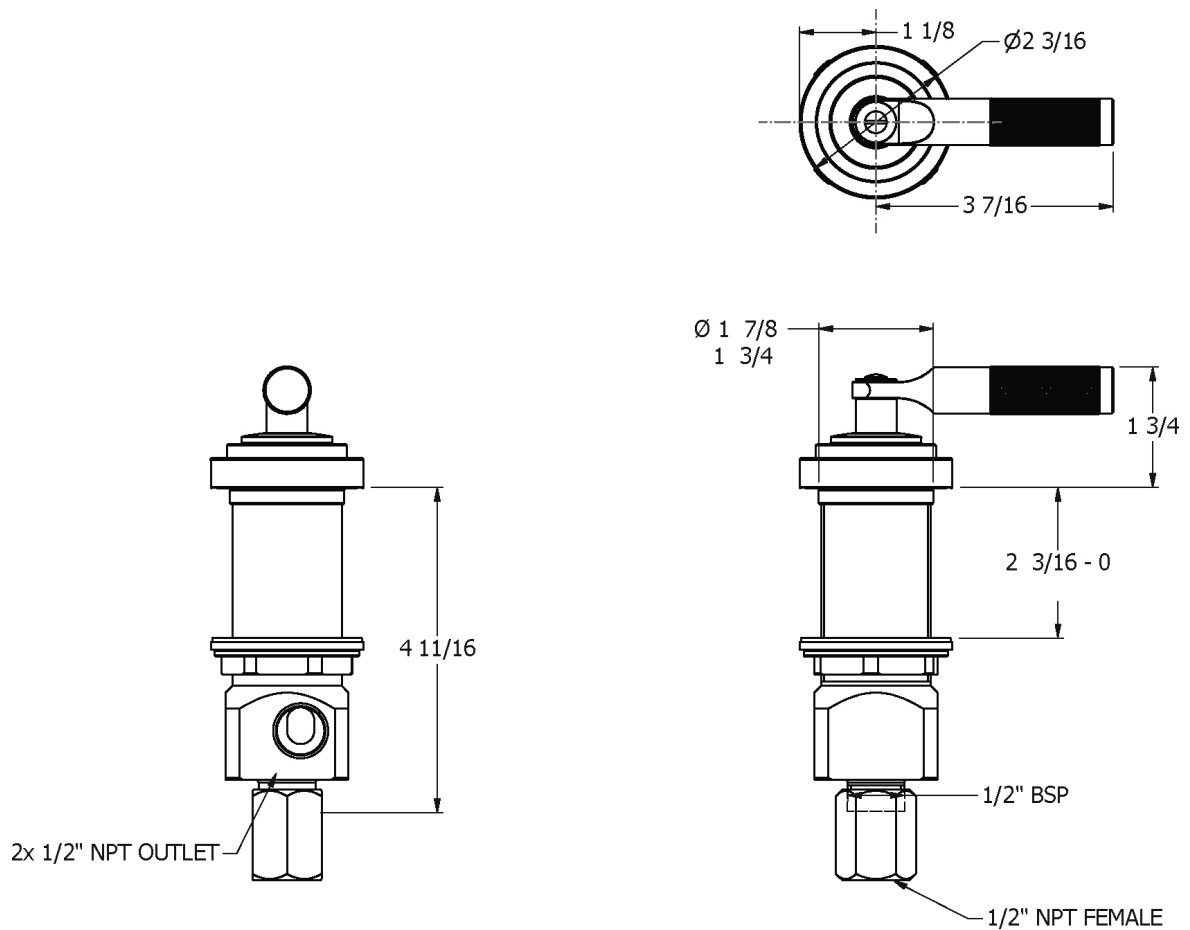

Dimension Key

V7KA41XF

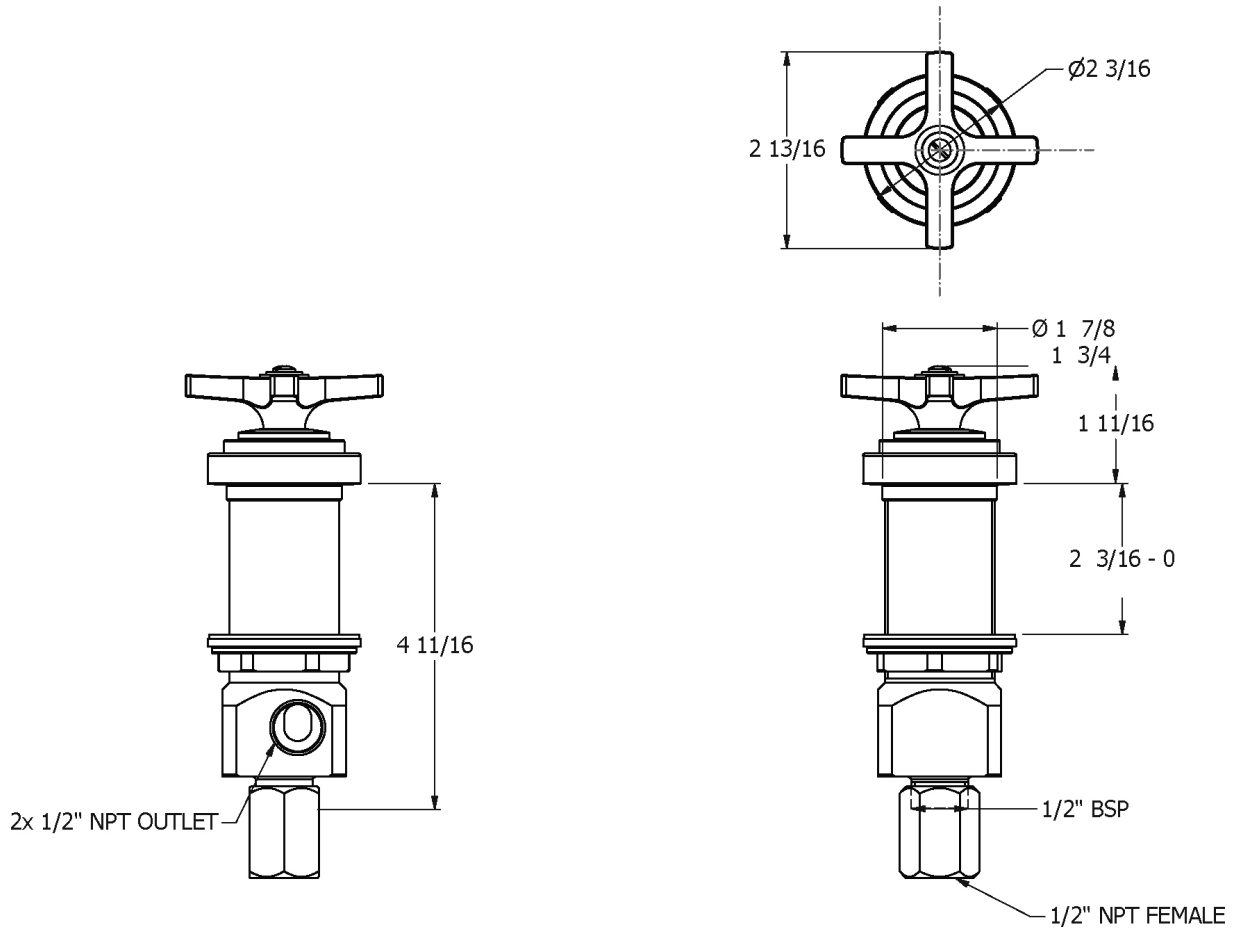

V7KA41XK

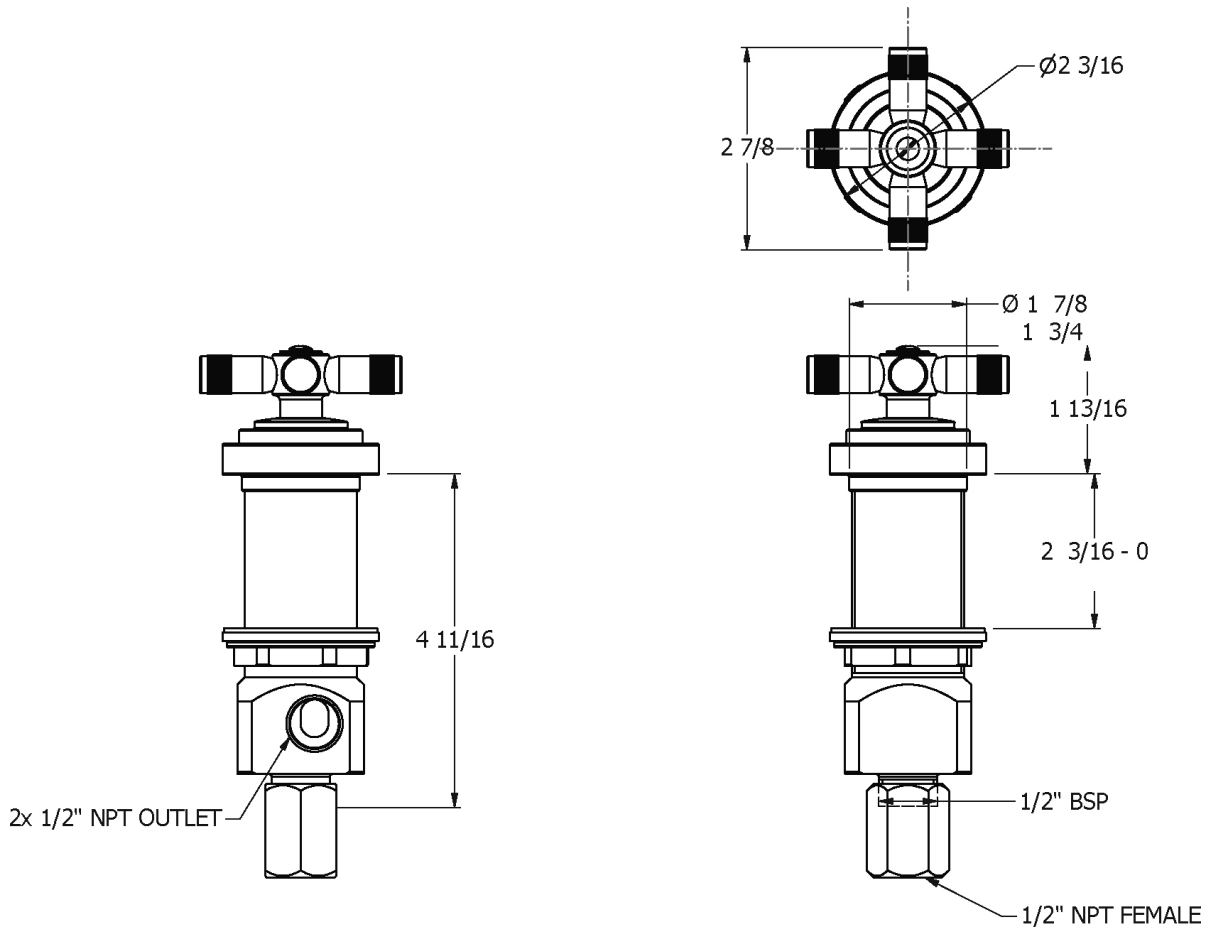

Flow Rates

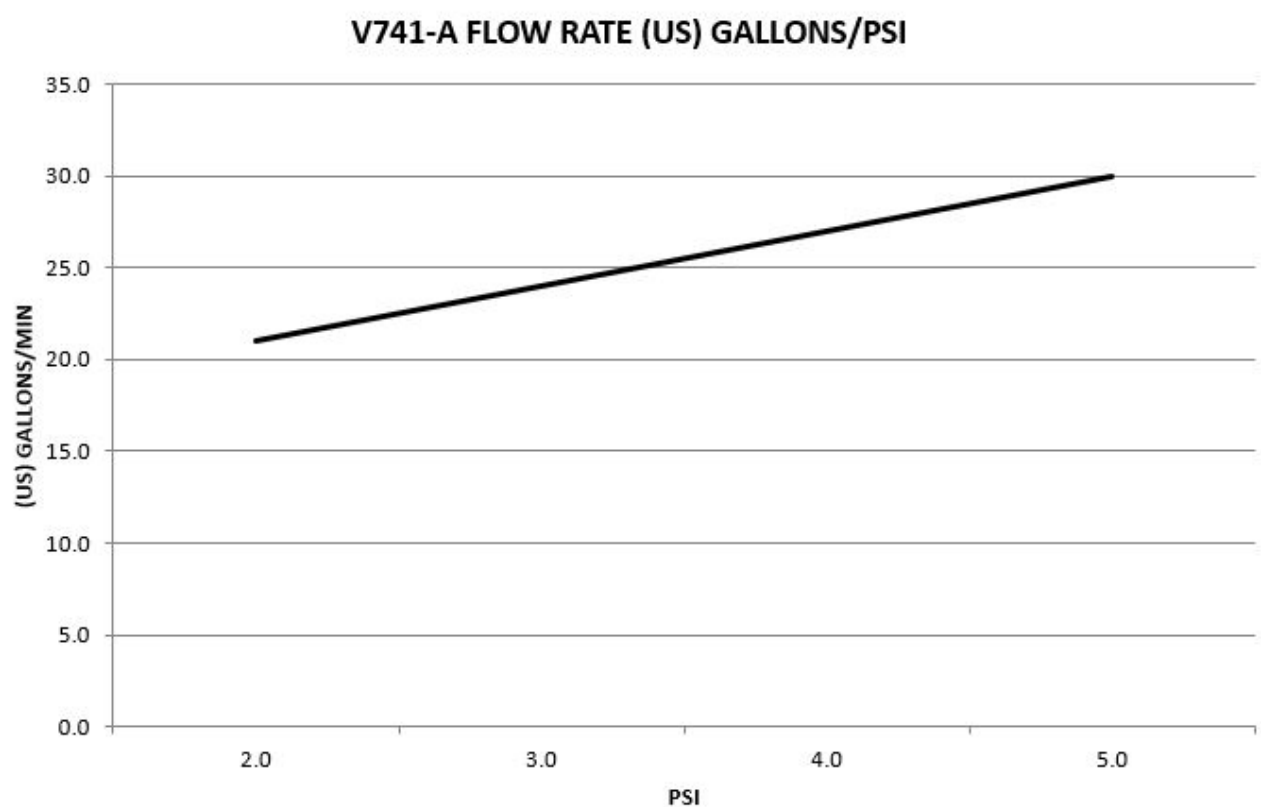
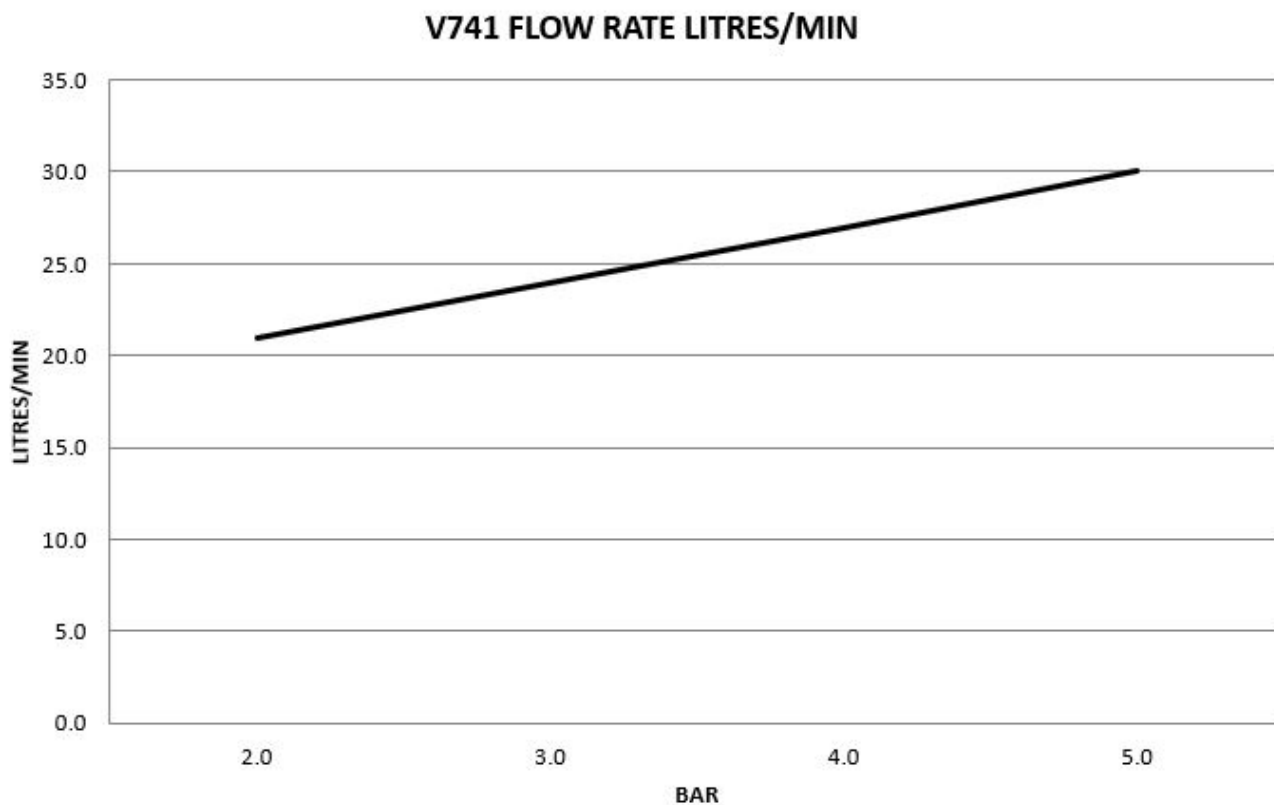

The flow rate data provided in this document is indicative of each product and is given in an open outlet condition. Installation design, external connections and fittings not supplied may affect the data provided.

Spares Information

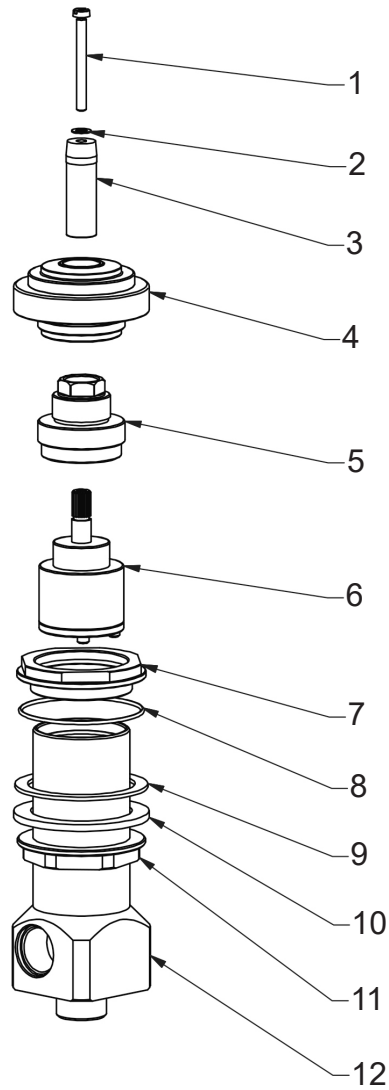

Item	Part No.	Description
1	-	Screw
2	-	Washer
3	-	Spindle
4	-	Escutcheon
5	-	Lock Nut
6	VS50022	Diverter Cartridge
7	-	Deck Nut
8	-	O-Ring
9	-	Rubber Washer
10	-	Stainless Steel Washer
11	-	Lock Nut
12	-	Diverter Body

Installation

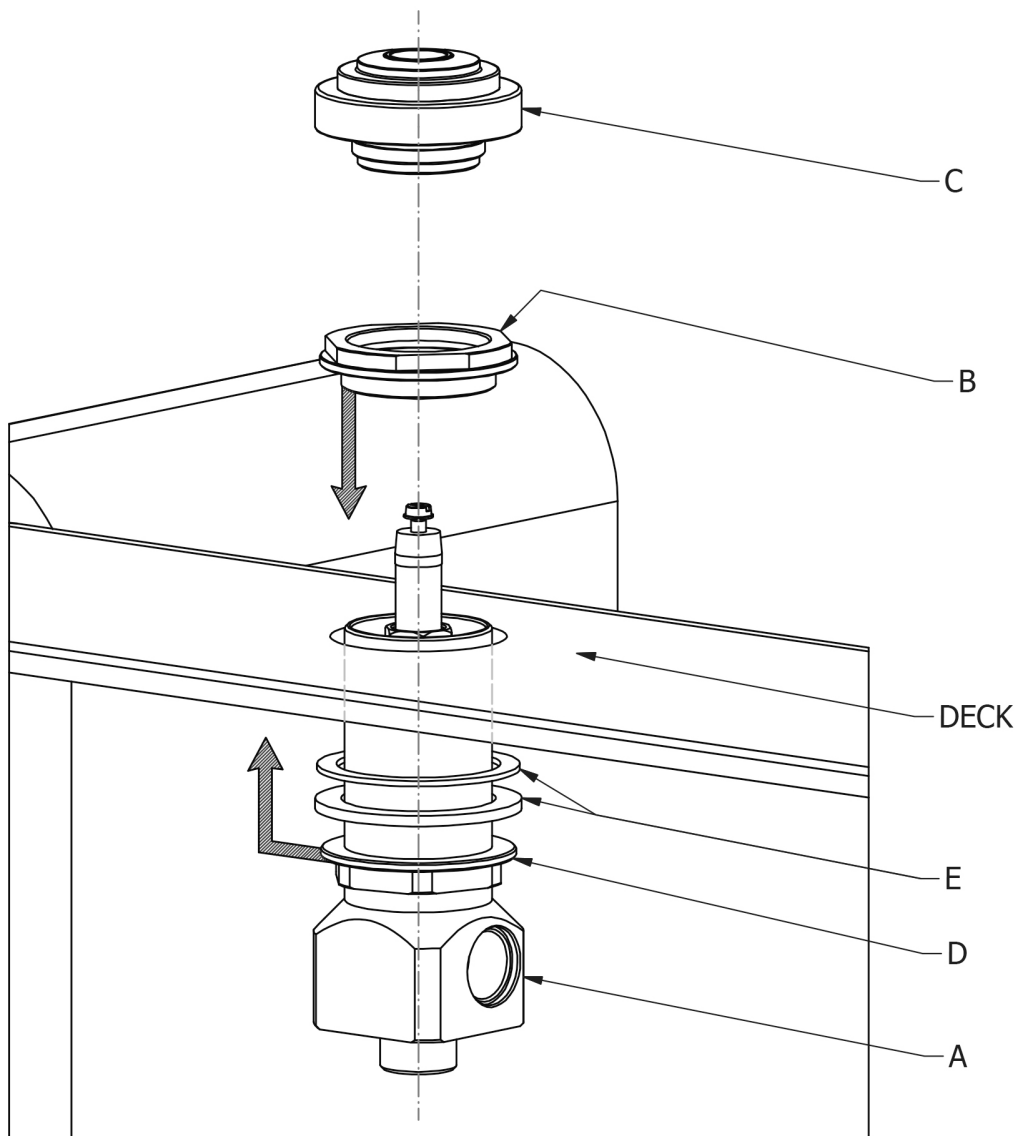

1. Secure valve body (A) to deck by screwing locking nut (B) into side valve body (A), ensuring locking nut (B) is above deck as shown.
2. Screw escutcheon (C) into valve body (A).
3. To secure assembly in place, screw back nut (D) & washers (E) up to the deck, as shown, as far as they will engage.

Installation

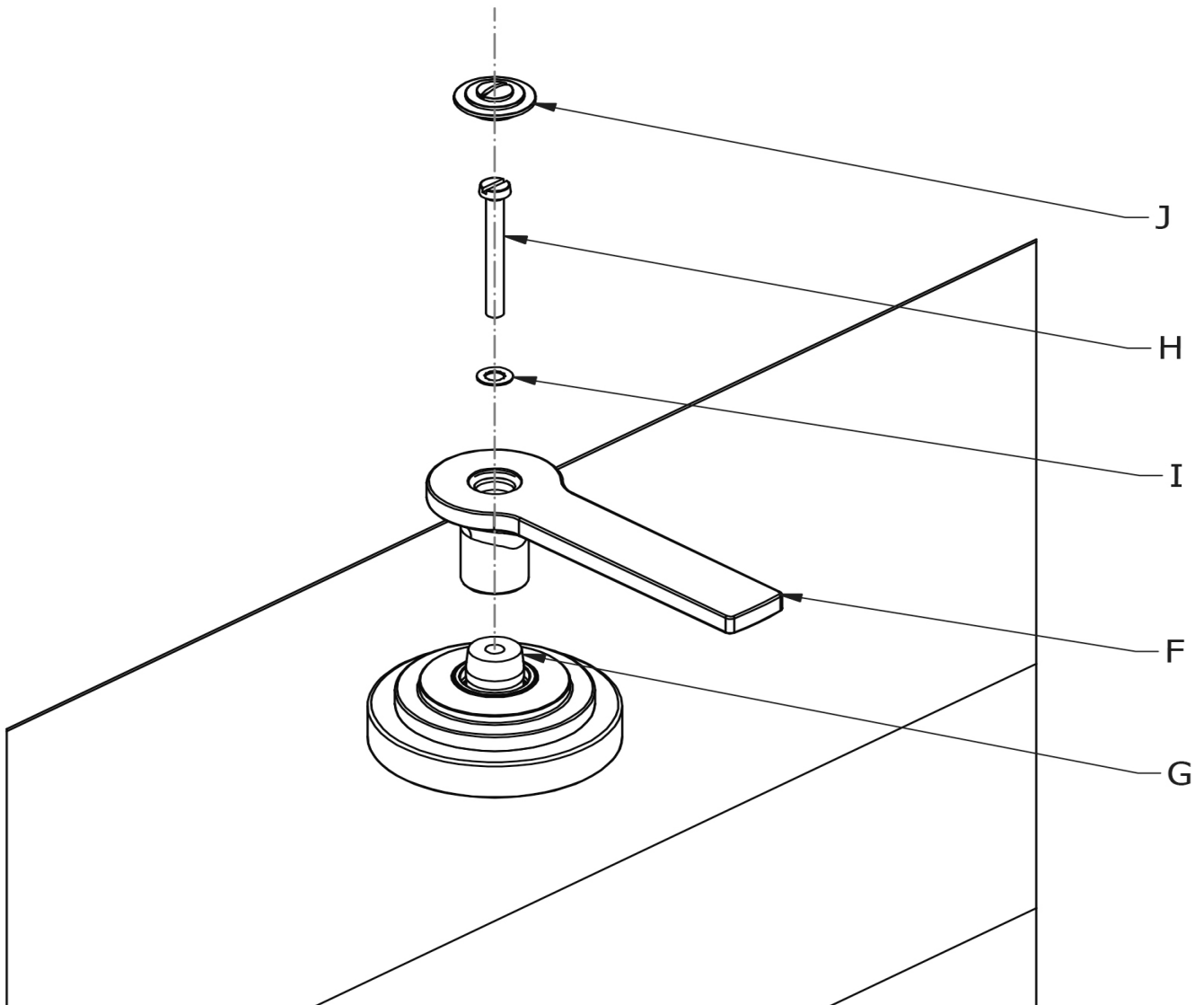

4. Attach control (F) onto spindle (G) and secure to assembly using screw (H) and anti-rotational washer (I).

5. Push indice cap (J) into control (F) to conceal screw.

Note: DO NOT discard of anti-rotational washer (I), it is imperative that this remains part of the product assembly.

Installation

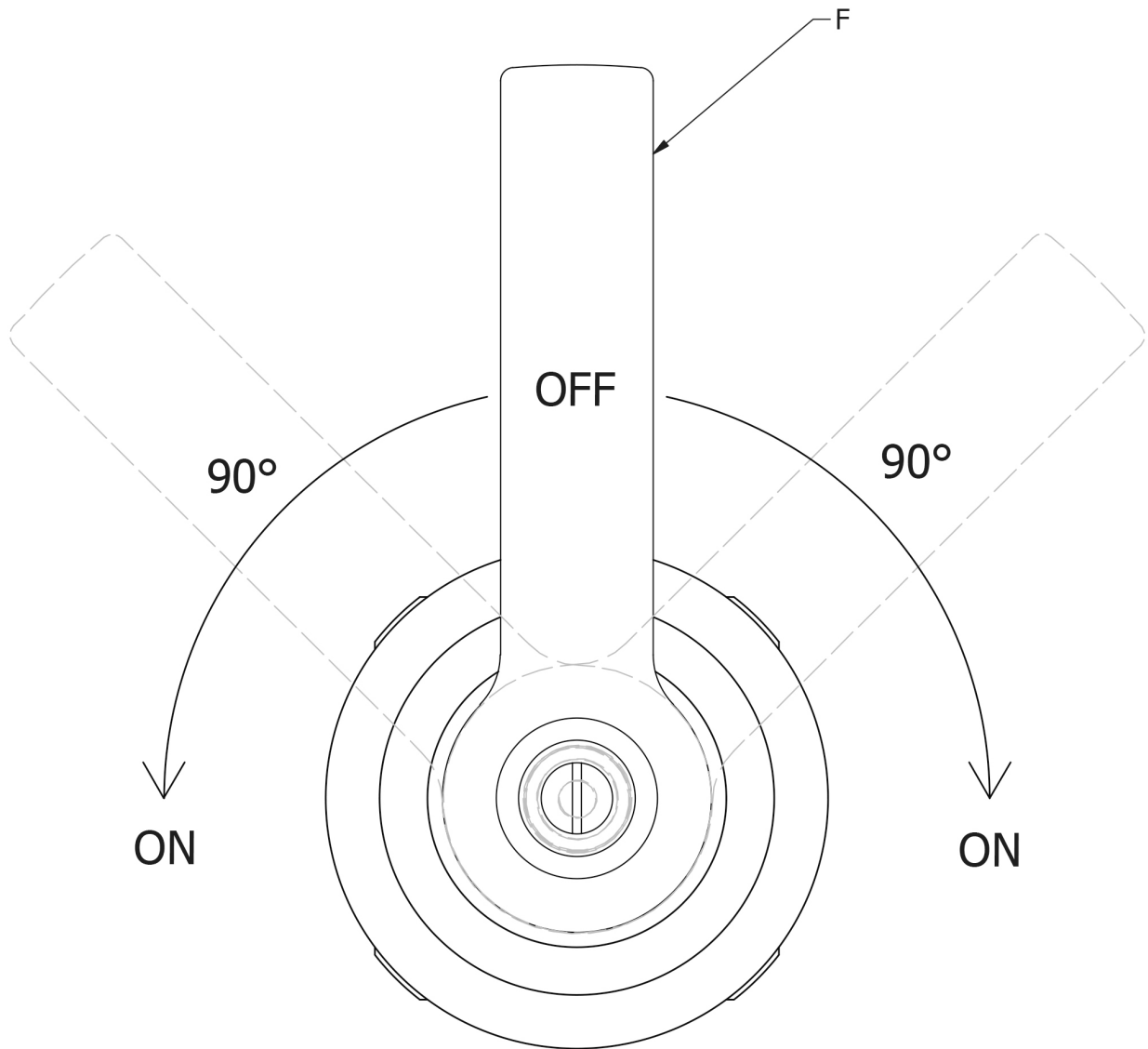

6. To operate the product, from the “off position” rotate the control (F) 90° anti-clockwise to divert to one outlet, or 90° clockwise to divert to the other outlet.

Inlets and Outlets

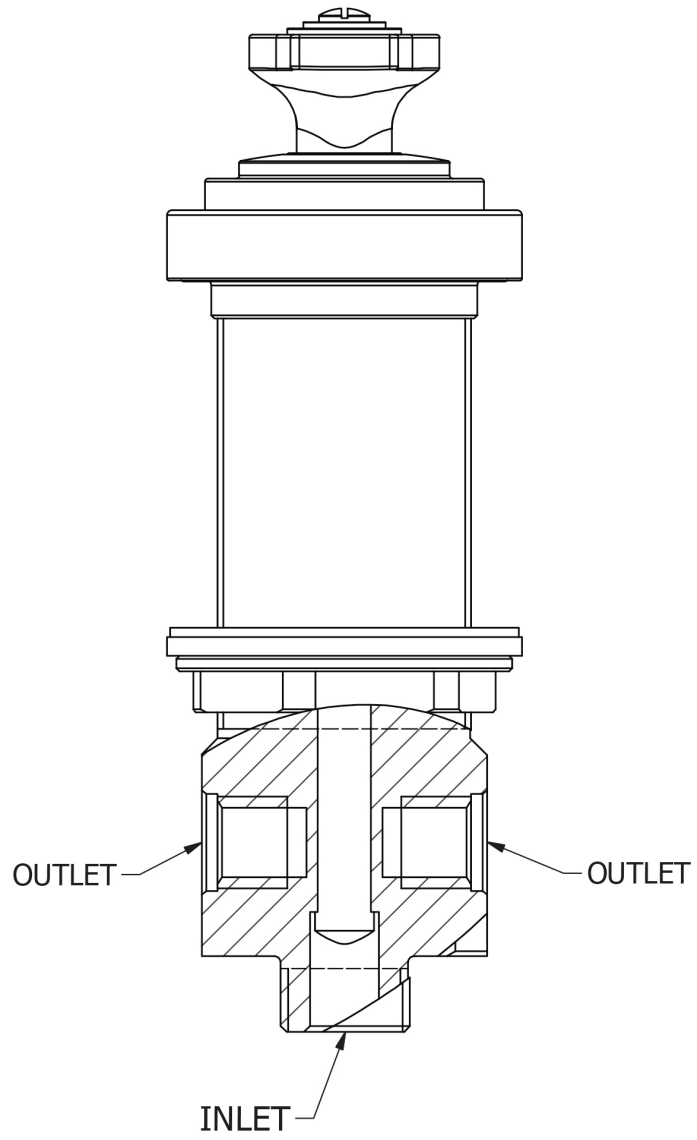

Accessing / Servicing The Cartridge

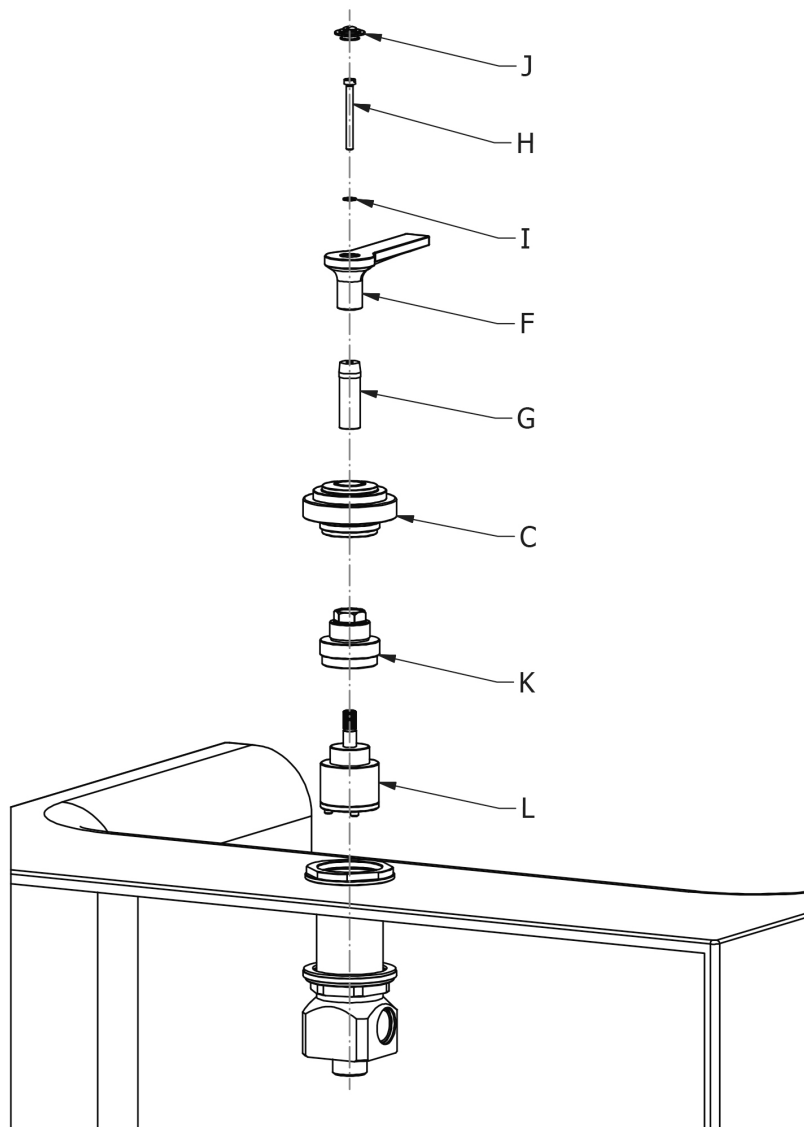

1. Remove index cap (J).
2. Unscrew screw (H), remove anti-rotational washer (I) then pull off control (F).
3. Pull out spindle (G) and unscrew escutcheon (C).
4. Unscrew locking nut (K) to reveal cartridge (L).

IMPORTANT NOTES

1. Installation should be carried out by a competent engineer, in accordance with water regulations.
2. Before installation, ensure supply pipes are flushed clean. Debris or loose particles will affect the efficiency of the ceramic disc cartridge.
3. For mixer taps, it is recommended that hot & cold pressures are equally balanced.
4. To help maintain the high quality finish, please clean with a soft damp cloth. Do not use abrasive polish or cleaners. Stains may be removed using undiluted washing up liquid.
5. Ceramic cartridges in hard water areas. To prolong the lifespan and reduce servicing periods of your Samuel Heath tap we recommend that a suitable water softener be fitted. Consult your installer/designer for details.
6. Please note that as with all tap and shower ware it will be necessary from time to time for the products to be serviced, this should be carried out by a qualified Plumbing Engineer.

NOTES IMPORTANTES

1. L'installation doit être faite par un ingénieur qualifié, selon les règlements du Service Eau.
2. Avant l'installation, il faut s'assurer que les tuyaux d'approvisionnement sont complètement purgés. Les déchets flottants auront un effet détriminaire sur l'efficacité de la cartouche céramique.
3. Il est recommandé que les pressions de l'eau chaude et eau froide des mitigeurs et mélangeurs soient maintenues à un niveau égal.
4. Pour conserver la finition de haute qualité, nettoyer avec un chiffon doux et humide. N'employer jamais de la cire et des produits abrasifs. Les tâches peuvent être enlevées à l'aide de liquide vaisselle pur.
5. Cartouches en céramique dans les régions à eau calcaire. Pour prolonger la durée et réduire l'entretien de votre robinetterie Samuel Heath, nous recommandons d'utiliser un adoucisseur d'eau convenable. Veuillez consulter votre installateur/fournisseur pour plus de renseignements.
6. Veuillez noter qu'un entretien sera nécessaire de temps en temps et doit être effectué par un installateur qualifié.

WICHTIGE HINWEISE

1. Installation sollte durch einen kompetenten Fachmann und nach den üblichen Vorschriften ausgeführt werden.
2. Vor Installation Wasserleitung gründlich durchspülen. Verschmutzung wird die Funktion der Kartusche erheblich einschränken.
3. Für Mischbatterien ist es wichtig, daß Wasser mit gleichem Druck eingeführt wird.
4. Um den optimalen Zustand dieses Produktes zu erhalten, wischen Sie es bitte nur mit einem feuchten, weichen Lappen ab. Auf keinen Fall Scheuermittel verwenden. Flecken lassen sich mit unverdünntem Geschirrspülmittel entfernen.
5. Keramikkartuschen in Hartwasserbereichen. Um die Lebensdauer zu verlängern und Wartungszeiten zu reduzieren empfiehlt Samuel Heath den Einsatz eines geeigneten Wasserenthärter. Fragen Sie Ihren Installateur/Designer um Rat.
6. Bitte merken Sie, dass alle Armaturen ab und zu eine Wartung brauchen. Diese soll durch einen kompetenten Installateur ausgeführt werden.

ATENCION

1. La instalación se debe realizar por un fontanero.
2. Antes de la instalación, deben pulgar las tuberías dejando correr el agua por las tuberías para que arrastren los residuos de montaje/obra, con el motivo de que no afecte la eficacia del cartucho de cerámica.
3. Para grupo baño/ducha se recomienda que las presiones del agua caliente y frío sean equilibradas.
4. Para ayudar a mantener el acabado de este producto, limpiar con un paño húmedo suave. No se debe emplear productos abrasivos de baño. Las manchas se pueden quitar empleando líquido lava-vajillas puro.
5. Cartuchos cerámicos en áreas de aguas duras. Para prolongar su vida útil y reducir los periodos de reparación de su grifo SamuelHeath recomendamos la instalación de un descalcificador de agua. Consulte a su instalador para más detalles.
6. Igual que con todo tipo de grifería y duchas, de vez en cuando será necesario llevar a cabo una revisión al producto; esto debería ser realizado por un fontanero calificado.

ATTENZIONE

1. L'impianto deve essere montato da personale tecnico in conformità alle vigenti leggi.
2. Prima dell'installazione assicurarsi che le tubature dell'acqua siano pulite. Detriti o residui di lavorazione compromettono l'efficienza del cartuccio.
3. Per i gruppi, si raccomanda che le pressioni acqua calda e acqua fredda siano ugualmente bilanciate.
4. Per mantenere la finizione di ottima qualità, pulire con un panno soffice e inumidito.
Non usare creme lucidanti e materiali abrasivi. Le macchie potranno essere tolte usando del detersivo per piatti puro.
5. Come con tutti i tipi di rubinetti e docce, di volta in volta è necessario effettuare una revisione al prodotto; questo dovrebbe essere fatto da un idraulico qualificato.

SAMUEL HEATH

Head Office and Customer Service

Leopold Street
Birmingham
England
B12 0UJ

T: +44 (0)121 766 4200
F: +44 (0)121 772 3334

Info@samuel-heath.com
www.samuel-heath.co.uk

US Customer Service

usa@samuel-heath.com
Federal I.D. No. 58-1504682
www.samuel-heath.com

8-40496
Issue: B