

Sentinel Mark II® Anti-Scald Balanced Pressure Exposed Shower

FEATURES:

- Brass body construction
- (2) 1/2" -14 NPTF inlets
- Pressure balancing & ceramic temperature regulating cartridge with built-in check valves
- Brass lever handle
- Adjustable temperature limit stop to control maximum temperature setting
- Supports back-to-back installation
- Vandal-resistant
- Shower head not included
- Polished stainless steel rain shower with 15-1/2" arm and supporting strap

SHOWER ADD-ONS:

- S-2762: Neo Rain Shower Head
- S-2763: Kubos Rain Shower Head

STANDARDS:

- ASSE 1016 certified
- ASME A112.18.1/CSA B125.1 certified

WARRANTY:

Visit www.speakman.com for full product warranty information

- 5 Year Limited Warranty (commercial)
- 5 Year Limited Warranty (residential)

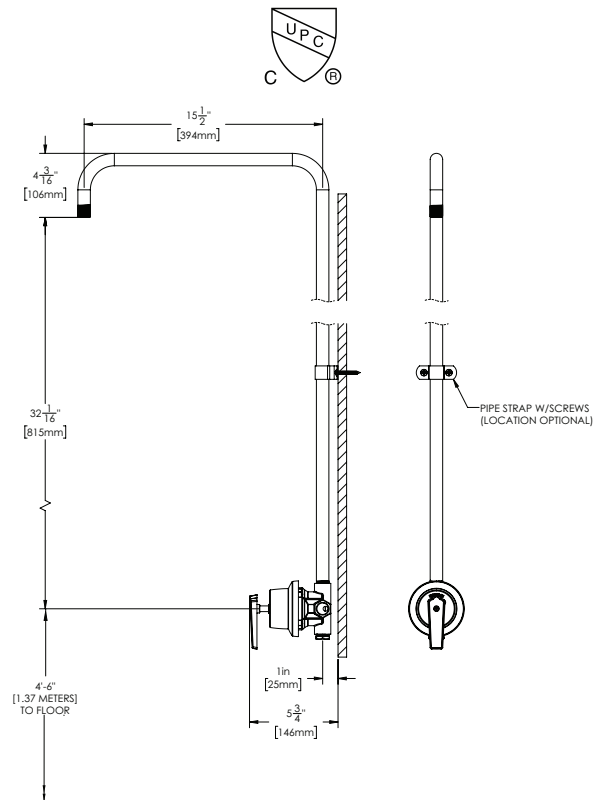

All dimensions are in inches (millimeters) unless otherwise specified and are subject to change without notice.

Architect/Engineer Approval Space:

P: 800-537-2107
F: 800-977-2747
W: WWW.SPEAKMAN.COM
R: 02-NOVEMBER 2019