

# CONTRACT SOAP DISPENSER PUM&DEPOSIT / BOMBA DOSIFICADOR EMPOTRABLE + BOTELLA

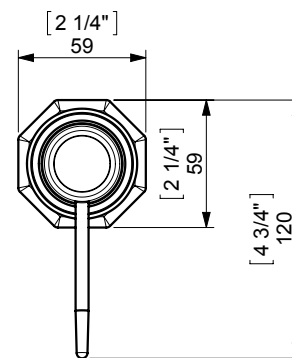
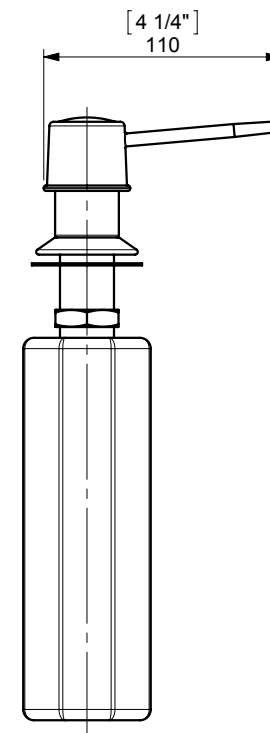
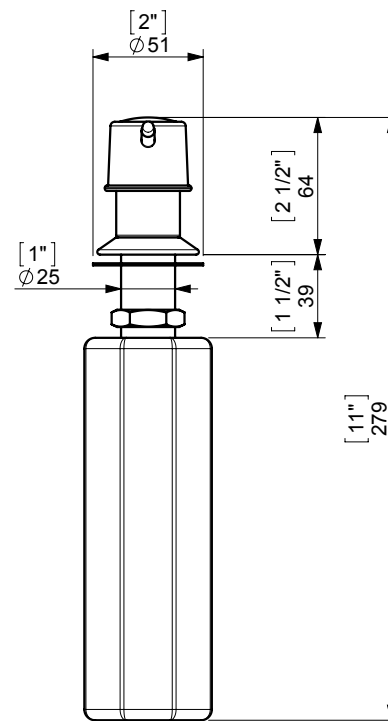
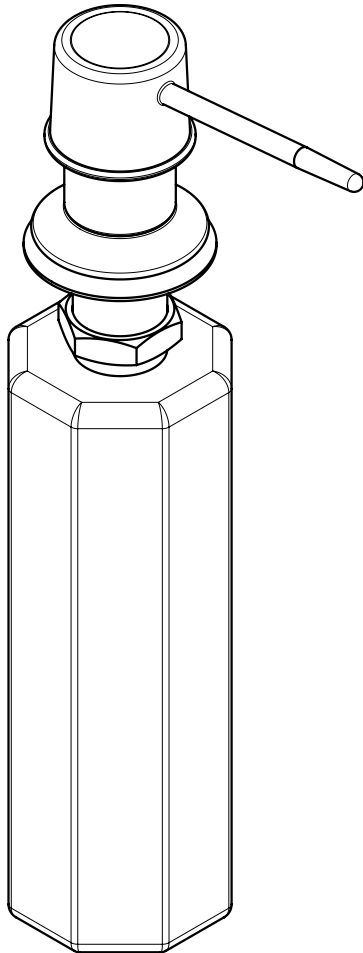

espec\_606

Imagenes no a escala / Draw not to scale / Echelle non respectée

Peso / Weight / Poids : 0,450 Kg.

Data / Datos / Données:

Normas / Regulations / Normes: UNE 67100, **UNE EN 3497**, **UNE EN ISO 1456**, **UNE EN ISO 9227**, **UNE EN ISO 4541**, **UNE EN ISO 2819**, UNE-EN ISO 4541

Sonia S.A se reserva el derecho de realizar cualquier cambio sin previo aviso  
Sonia S.A has the right to make changes without notice  
Sonia S.A se réserve le droit de procéder à tout changement sans notification préalable



www.sonia-sa.com