

# PUZZLE 18" DRAWER SIDE UNIT / AUXILIAR CAJÓN 45

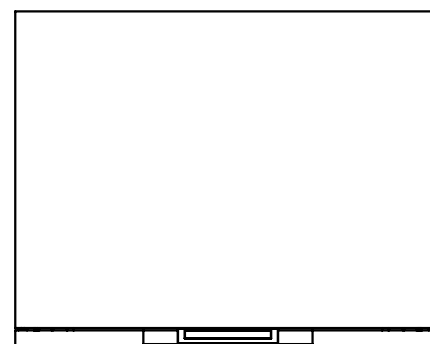
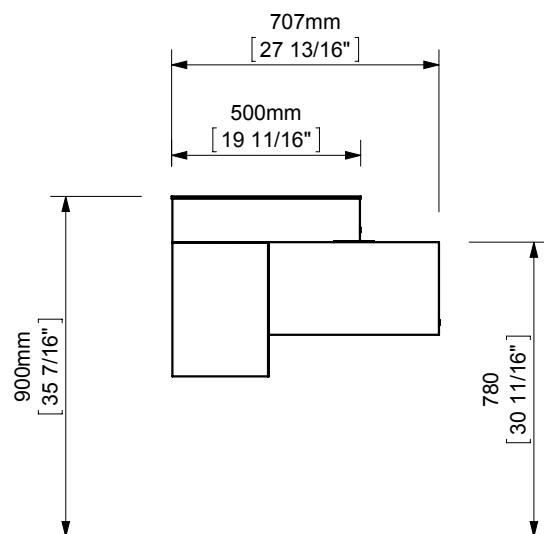
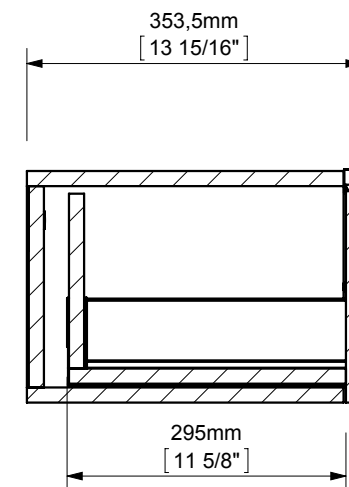
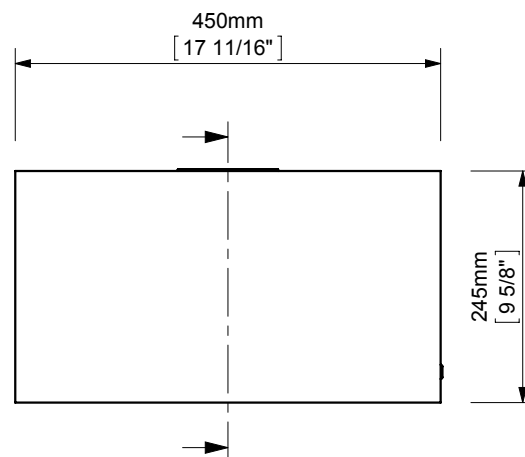
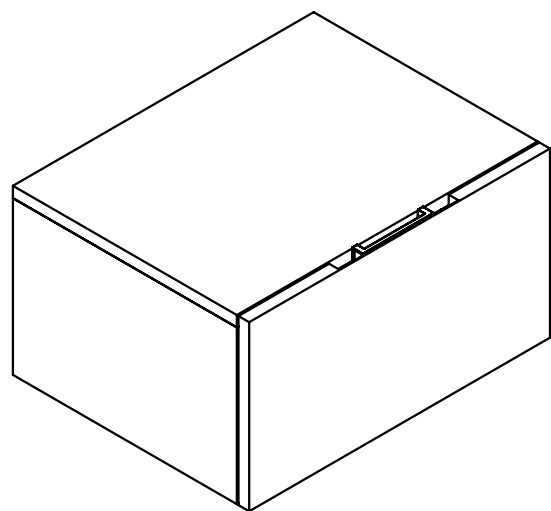

espec\_255

Imágenes no a escala / Draw not to scale / Echelle non respectée

Peso / Weight / Poids: 13Kg

Acabados / Finish / Finitions: Según tarifa vigente / As per valid pricelist / Selon le tarif en vigueur

Normas / Regulations / Normes: UNE 56867, UNE 56868, UNE EN14749

Sonia S.A se reserva el derecho de realizar cualquier cambio sin previo aviso  
Sonia S.A has the right to make changes without notice  
Sonia S.A se réserve le droit de procéder à tout changement sans notification préalable



www.sonia-sa.com